

The Tenerife Property & Business Guide



Digital only Edition | May 2020 Issue 187

Tel: 922 703 725 • Email: george.thetpg@gmail.com • www.thetenerifepropertyguide.com



The beautiful coast of Puerto de la Cruz

Dr. Stange und Partner
Established 1986

649 95 69 39

FOR SALE! – CAFÉ BAR / RESTAURANT

In prime position on the busy sea-front promenade in Fañabe/Costa Adeje. Fully renovated and equipped. All year-round tourism. 75m2 interior with 50m2 terrace. Great opportunity for the right couple!

PRICE: €69.500,-. MONTHLY RENT: €3.450,-

POWER ON FM

TENERIFE 89.5, 89.8 & 93.7 FM

BROADCASTING FROM

MASCA TO ARICO

WHEN IT'S ON, IT'S ON!

WWW.POWERONFM.COM

COME AND VISIT
THE BEAUTIFUL

MY THAI LOUNGE
PUERTO COLON MARINA

See Page 55 for details



SAFECCLEAN
PART OF G.D.A. GROUP S.L.U. Est 1987

PEST CONTROL

For private villas, apartments, complexes, providing sanidad

certificates for Bars & Restaurants
CONTROL DE PLAGAS

Desinsectación, desratización y certificados

www.safecleantenerife.net

609 066 973

627 114 090

CLEANING

Professional upholstery & carpet cleaning, sofas, beds

LIMPIEZA

Limpieza de sofás, alfombras, tapizados etc.

e-mail: info@safecleantenerife.net



Contents

- 03-33** Residential Sales
- 34** Monthly Currency update (Currencies Direct)
- 38** Official Registration of Alterations or Extensions to Properties
- 40** Article: What is climate change? A really simple guide
- 40** Article: Is sugar really bad for you?
- 44** Article: What leader are you? It depends on your parents
- 46** Article: Much of Your Daily Life Depends on Discoveries Made by Astronomers
- 48** Article: Oceans could return to a picture of health in just one generation
- 50** Article: Tree rings tell a story of water and climate change
- 50** Archaeology bombshell: How historians unearthed 'Spanish Stonehenge' in breakthrough find
- 55** Studio4Decor in Los Abrigos is expanding!
- 56-57** Sebastian St James IFAs
- 59** Long Term Rentals
- 61** Businesses for Sale

A COUPLE OF PIECES OF 'CORONAVIRUS POSITIVE'



This youngster has wanted to do this for weeks, but was told it was just a pipe dream!

The joy of Spain's freed children

by Thom Gibbs and Harriet Barber, The Telegraph

One enormous upside of lockdown is that, eventually, it has to end. That's going to manifest itself in all sorts of different ways, for example, a resumption of family gatherings for some, an all-day bender in the park on tinned cider and McChicken nuggets for others. While there is a sense that some of us may re-

enter exterior life more gingerly, perhaps those of us who've found being indoors for 99 per cent of the last few weeks less taxing than expected, there is no such reticence from the children of Spain and its Overseas Territories. We've seen giddy pictures from over the weekend as the young people of the country celebrate being allowed outside for an hour a day for the first time in 44 days.

This is how we're all

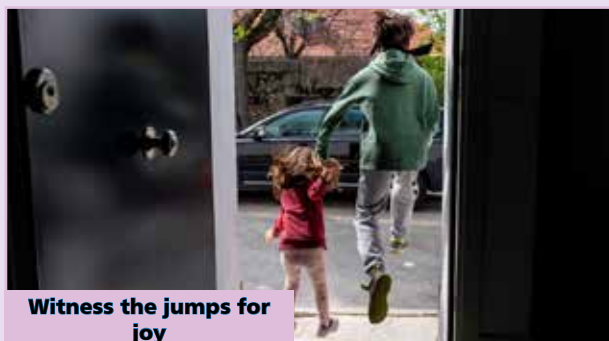

Witness the jumps for joy

going to feel when we're allowed to go back to work!

Though our blessings may be well disguised in this pandemic, we must still count them!

By Mark Rice-Oxley, The Guardian

I'm not sure where I read this – it may well have been in a wonderful novel by Taffy Brodesser-Akner. Like all the best epigrams, it is deeply wise, even if it overgeneralises. I can't think of many instances from my own life where it isn't true. A breakdown, a miscarriage, a job lost – they all led to better things.

The phrase reminds me of something Winston Churchill supposedly said on losing the 1945 election. His wife apparently told him that defeat may well have been a blessing in disguise. "Madame, if this is a blessing, it is indeed well disguised," he replied. And yet a blessing it was. Britain got Attlee, the welfare state, the NHS. Churchill got a rest, and then his swansong six years later. The rest is history.

Elsewhere, France and Italy are also easing

lockdown rules. In the UK, various sports have begun crunching the numbers to work out how many people will be required in stadiums to host games. I'll take any sort of televised sport to be honest. Bring on the World Cup of tidlywinks...

And the rest of today's cheery news from Harriet Barber:

- To celebrate Captain Tom Moore's 100th birthday on Thursday, all mail this week will be marked with "Happy 100th Birthday Captain Thomas Moore NHS fundraising hero 30th April 2020."

- People across the UK have been buying NHS-inspired football scarves this month, raising £8,000 for meals for medical workers. Thirty-five food drops have taken place across London, with more planned in the coming weeks.

- Health officials in Odisha, India believe the addition of new ventilators will significantly reduce snakebite deaths. At least 723 people died last year from snake bites but officials believe hundreds of lives will now be saved as public hospitals will be able to combat respiratory failure caused by toxins in venom. On April



Witness the first steps into a brave new world

14, the country ordered over 400 new ventilators.

- Wrexham driving instructor Nigel Richards has swapped his 'L' plates for a 'Covid-19 Delivery' sign. Instead of teaching, Mr Richards is volunteering to deliver prescriptions for his two local surgeries in Brynteg and Brymbo, Wales.

- Thousands are signing up to newly-created delivery services that will help independent shops to survive the lockdown. UKDelivers started in Deal, Kent to help support local shops and has already been expanded to locations in London and Surrey. The websites, such as Deal Delivers or Reigate Delivers, allows local shops

to list for free online and has been described as a "hyper-local Yellow Pages". Calypso Rose, an entrepreneur and the founder of the project, said: "Even though we are all socially distancing or in isolation, community has never been stronger. This is a community working at its best."

- For the first time in six weeks Malta has reported no new cases of coronavirus.

- Within hours of a contact tracing app being released in Australia millions had downloaded it. Users will be notified if they've spent more than 15 minutes with another user who later tests positive.



DIRECT FROM OWNER

GOLF DEL SUR, LOS ALAMOS

Price: €599.995



Magnificent, fully furnished and equipped, 4 bedroom - all en suite - villa, plus independent 3 bedroom, 1 bathroom apartment (with own entrance) comprising own heated swimming pool, al fresco dining area, gardens and games area in this exclusive location.

This substantial property (280sqm built on a 1,000sqm plot) exudes quality, with 'wet room' style granite-floored shower/bathrooms throughout and really too many 'extras' to list here.



Close to the San Blas Commercial Centre's excellent shopping, bars and restaurants, the sea front walkway to the popular fishing village of nearby Los Abrigos, championship golf courses at Golf del Sur and Amarilla Golf and myriad water sports including the wind-surfing paradise of El Medano, there is so much for people to do. The 'South' airport is less than 10 minutes away as are the popular resorts of Los Cristianos and Las Americas



**For more information, or to arrange a viewing,
please call 649 038 622**



Villas La Capitana, El Galeón



- 4 bedrooms
- 2 bathrooms
- Close to amenities
- Gated community
- Popular urbanisation
- Sea views
- Furnished
- Immaculate condition
- Sunny terrace
- Communal pool

150 90

Price: 440,000€ Ref: 4V3471

Villa Teide, San Eugenio Alto



- 3 bedrooms
- 2 bathrooms
- Quiet location
- Close to amenities
- Sea views
- Refurbished
- Furnished
- Immaculate condition
- Private pool
- Various terraces

100 120

Price: 472,500€ Ref: 3V3469

Las Pergolas, El Madroñal



- 4 bedrooms
- 2 bathrooms
- Close to amenities
- Gated community
- Residential area
- Sea/mountain views
- Independent kitchen
- Furnished
- Private pool
- Various terraces

160 300

Price: 485,000€ Ref: 4TH3470

Los Atamanes/Sun Set Bay, Torviscas Bajo



- 2 bedrooms
- 2 bathrooms
- Central
- Close to amenities
- Sea views
- Furnished
- Various terraces
- Street parking
- On-site supermarket

75 18

Price: 370,000€ Ref: 2D3465

Benimar, Bahía del Duque



- 1 bedroom
- 2 bathrooms
- Close to amenities
- Gated community
- Sea and mountain views
- Furnished
- Sunny Terrace
- Underground parking
- Community pool

70 13

Price: 245,000€ Ref: 1A3458

Oasis, San Eugenio Alto



- 1 bedroom
- 1 bathroom
- Central
- Close to amenities
- Close to beach
- Sea, garden views
- Furnished
- Sunny terrace
- Community pool
- Street parking

48 15

Price: 129,000€ Ref: 1A3433

Res. Paraiso II, Playa Paraiso



- 2 bedrooms
- 2 bathrooms
- Close to coast
- Sea views
- Open plan kitchen
- Furnished
- Sunny balcony
- Underground parking
- Community pool

70 8

Price: 220,000€ Ref: 2A3460

Club Paraiso, Playa Paraiso



- 2 bedrooms
- 2 bathrooms
- Close to amenities
- Close to the beach
- Sunny Terrace
- Communal parking
- Community pool
- Open plan kitchen
- Well presented

90 16

Price: 245,000€ Ref: 2A3459

Arco Iris, Callao Salvaje



- 2 bedrooms
- 2 bathrooms
- Gated community
- Close to amenities
- Close to beach
- Furnished
- Large terrace
- Community pool
- Open plan kitchen

73 14

Price: 200,000€ Ref: 2D3467

Las Galletas



- Studio
- 1 bathroom
- Second line to beach
- Touristic area
- Close to amenities
- Central
- Furnished
- Sunny terrace
- Street parking

45 6

Price: 85,000€ Ref: 0S3468

Sand Club, Golf del Sur



- 1 bedroom
- 1 bathroom
- Close to amenities
- Close to coast
- Popular urbanisation
- Sunny terrace
- Community pool
- Refurbished
- Immaculate condition

45 8

Price: 157,500€ Ref: 1A3462

El Mocan, Palm Mar



- 1 bedroom
- 1 bathroom
- Residential area
- Gated community
- Close to coast
- Furnished
- Sunny terrace
- Underground parking
- Community pool

54 6

Price: 149,000€ Ref: 1A2966

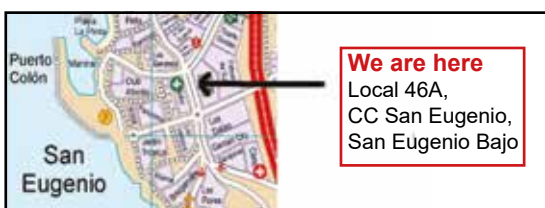

We are here
Local 46A,
CC San Eugenio,
San Eugenio Bajo

- Bank Repossessions
- Luxury Villas
- Resort and Residential Properties
- Investment Opportunities
- New Developments
- Relocation Assistance

www.hofmanestates.com

Office: 922 77 77 47

Email: info@hofmanestates.com





Fully furnished 1 bed, 1 bath apartment on gated, popular urbanisation in residential area. The property is in immaculate condition, with open-plan kitchen, storerooms, nice terrace, and underground parking, and is centrally located close to the beach, and amenities. There is also a community pool and children's pool.

Price: 139000€ Ref: 1A3472



Oasis, San Eugenio Alto

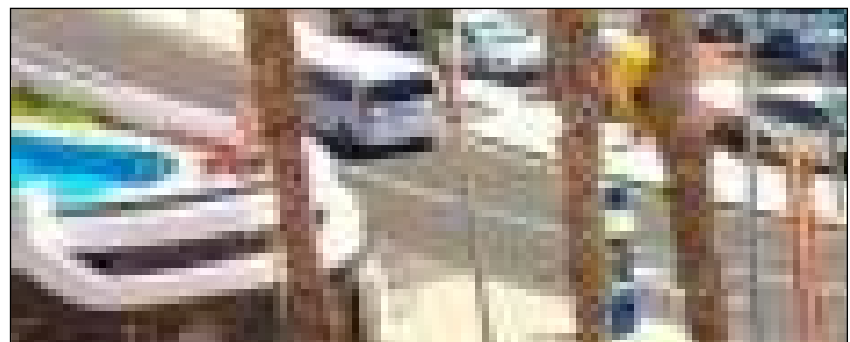

Lovely, fully furnished, centrally located 1 bed, 1 bath apartment on popular, gated urbanisation with pool and gardens in touristic area. The property has a lounge/diner, American kitchen, sunny terrace which enjoys sea, pool, and garden views, and is located close to amenities.

Price: 180,000€ Ref: 1A3464

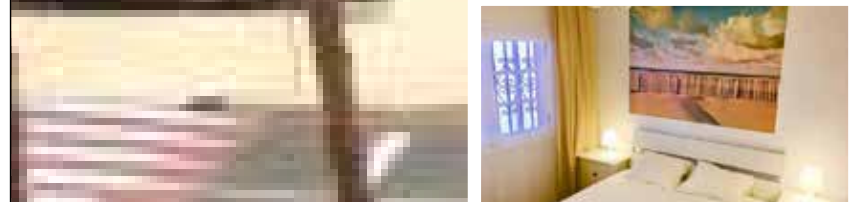

Garden City, San Eugenio Bajo



Very nice, fully furnished, 1 bed, 1 bath apartment on popular Touristic complex with pools and sunbathing terraces. This centrally-located property has a lounge/diner, open plan kitchen and a large sunny terrace with garden views and is located close to all amenities and the sea front/harbour.

Price: 195,000€ Ref: 1A3461



We are here
Local 46A,
CC San Eugenio,
San Eugenio Bajo

- Bank Repossessions
- Luxury Villas
- Resort and Residential Properties
- Investment Opportunities
- New Developments
- Relocation Assistance

www.hofmanestates.com

Office: 922 77 77 47

Email: info@hofmanestates.com





Est. 2007

www.tenerifehome.com
Follow us on Fb 

1st LINE TO THE SEA!

**Costa del Silencio, Balcon del Mar**

Spacious (137sqm built + 2 terraces totalling 17.75sqm) 3 bed, 2 bath apartment with stunning sea views on this popular sea front complex with lovely pool area. The property has a lounge/diner, open plan kitchen, storeroom and 2 private parking spaces and is close to amenities.

Ref: 955-1213

€299,000

**Costa del Silencio, Balcon del Mar**

Fully furnished, well-maintained 1 bed, 1 bath first floor apartment on this sought after, sea front complex with beautiful pool and sunbathing terraces. The property enjoys lovely sea views and has a lounge/diner, open plan kitchen and a sunny terrace. Great value!

Ref: 50-0320

€155,000

**Costa del Silencio, La Hacienda**

Very nice, fully furnished, 1 bed, 1 bath top floor apartment on lovely complex with pool. The property has a lounge/dining area, open plan kitchen south-facing terrace, a roof terrace and a private parking space.

Ref: 1322-1017

€139,000

**Costa del Silencio, Chafofita**

Spacious (58sqm), 1 bed, 1 bath 1st floor apartment with a 12sqm sunny terrace on this popular complex with pools. The property has a lounge/dining area and a fully fitted, open plan kitchen.

Ref: 44-0220

€105,000

**Costa del Silencio, Chayofita**

Fully furnished, 2 bed, 1 bath 1st floor apartment on popular complex with pool. Close to amenities. The property has a lounge-diner, 2 sunny terraces plus balcony and an open plan kitchen.

Ref: 41-0120

€99,950

**Llano del Camello**

Spacious (94sqm), 2 bed, 2 bath 2nd floor apartment in residential complex. The property has a lounge/diner, separate kitchen, sunny terrace plus huge roof terrace with views over the countryside. Community Fees: €68 per month.

Ref: 37-0120

€149,500

**Costa del Silencio, Amarilla Bay**

Spacious (60sqm), fully furnished 1 bed, 1 bath apartment in a fantastic location overlooking 'Yellow Mountain' on complex with a lovely pool area. The property has a lounge-diner, open kitchen and a 12sqm sunny terrace. Community parking.

Ref: 20-1019

€179,000

**Costa del Silencio, Palia Don Pedro**

Fully renovated 1 bed, 1 bath apartment in popular aparthotel with parking and community pool. The property has a lounge-diner, open plan kitchen and south-east-facing sunny terrace

Ref: 1311-0917

€99,900

**Costa del Silencio, Maravilla**

Lovely, spacious (117sqm), fully furnished 2 bed, 2 bath (1 en suite) apartment the sea front complex with heated pool. The property enjoys partial sea views and has a lounge/diner, semi-sep. kitchen and a 28sqm sunny terrace. Communal parking.

Ref: 1501-0719

€258,000

**Costa del Silencio, Parque Don Jose**

Fully renovated and furnished 1 bed, 1 bath apartment on sought after complex with spectacular pool area. The property has a lounge-dining area, modern kitchen with island, sunny 10sqm terrace. Community fees: €96 /month.

Ref: 1483-0419

€155,000

C.C. El Trebol, Local 37,
Avda. J. A. Tavio,
COSTA DEL SILENCIO,
38630, Tenerife.

We work efficiently, transparently,
and speak YOUR language!

English · Español · Français
Deutsch · Nederlands

+34 690 363 653
+34 922 783 066
info@tenerifehome.com



2NDHOME
TENERIFE

**Specialists in New Developments,
Resales & Rentals**



IN EXCLUSIVITY



Brand new project for sale in Palm-mar:
Enjoy leisure activities & peaceful
environment close to the sea.

DEVELOPER:
metrovacesa
EDIFICIO GARA

Apartment with 2 & 3 bedrooms
with parking space and storage room.

For more information
please contact us:

commercialdirector@secondhometenerife.com

Prices from:
348.500€



Dorothee Robert
Commercial Director
+34 628 608 469
commercialdirector@secondhometenerife.com



www.2ndhometenerife.com

Terrazas del Duque
Av. Bruselas, 18
Edf. Terrazas del duque. Local 6
Costa Adeje
Tel. 922 715 591

Plaza del Duque
CC Plaza del Duque
Nivel -1, Kiosko E
38660 Costa Adeje
Tel. 922 718 193

Palm-Mar
C/ La Garza, 2
Edf. Terrazas del Faro
Arona
Tel. 922 748 006

Playa Paraiso
Av. Playa Paraiso, 2
Edf. Gran Azul, local 11
38678 Playa Paraiso
Tel. 922 741 866

Jardin La Caleta
Av. de Las Gaviotas, 35
Local 1
La Caleta
Tel. 922 168 058

TENERIFE PROPERTY SHOP S.L.

G.I.P.E. NO. 3722

- ✓ Reliability
- ✓ Professionalism
- ✓ Security
- ✓ Service
- ✓ The BEST Portfolio

Service



Security

OUR OFFICE LOCATIONS:

CC San Blas - Golf del Sur

Las Adelfas I - Golf del Sur

CC Puerto Colon - Playa de Las Américas

NEW!

2 BED APARTMENT - GOLF DEL SUR

RENTAL INVESTMENT!

This spacious two bedroom apartment is perfect as a holiday home, a winter base or even as a rental investment at a great price! Based on a tourist complex with three swimming pools, community garden, reception area as well as a pool bar and a selection of bars and cafes within the complex. There is a choice of supermarkets nearby. The property is modern in style and is sold furnished.

Ref: GOLF01622
Price: €115,000 (approx. £97,500)

EXCLUSIVE

2 BED APARTMENT - GOLF DEL SUR

TURNKEY PROPERTY!

This ground floor apartment, converted from one bedroom to two, is light, spacious & in excellent condition. Fully furnished with open plan kitchen, en-suite bathroom, satellite TV & plenty of outside space with a covered terrace & small private garden with pool views. Based on a well maintained complex with 2 heated pools set amidst tropical gardens, close to all amenities, this is well worth putting on your viewing list.

Ref: GOLF01611
Price: €155,000 (approx. £131,500)

NEW!

1 BED APARTMENT - AMARILLA GOLF

REFURBISHED PROPERTY!

This ground floor refurbished one bedroom, one bathroom apartment comes furnished with fully equipped kitchen, fitted wardrobes, sunny terrace, communal pool & garden. Located on a quiet residential complex close to all local amenities & the golf club house. With a pleasant garden view and just a few steps to the pool. Ideal for a holiday home or that winter retreat you have always promised yourself.

Ref: AMG00549
Price: £142,000 (approx. €162,000)

NEW!

2 BED APARTMENT - AMARILLA GOLF

SPACIOUS APARTMENT WITH PARKING!

This spacious two bedroom garden apartment is perfect as a winter holiday home or a permanent residence! Just a short walk from all local amenities, the beautiful San Miguel Marina and Amarilla Golf Course and even Golf del Sur! With two large double bedrooms (the master bedroom is very spacious!) a fully fitted bathroom and a new open plan modern fitted kitchen and lounge area. With parking.

Ref: AMG00550
Price: £155,000 (approx. €172,500)

NEW!

1 BED APARTMENT - LOS CRISTIANOS

SEAFRONT LOCATION!

A rare opportunity to own an excellent one bedroom garden apartment in one of the most popular complexes in Los Cristianos. Based on the popular, and very well maintained Paloma Beach complex. Ideally located close to the seafront, a host of local bars and restaurants, this secure holiday complex has a beautiful pool area and gardens to enjoy all year round.

Ref: LC00590
Price: €224,000 (approx. £190,000)

NEW!

3 BED TOWNHOUSE - CHAYOFA

IDEAL HOME OR WINTER BASE!

An attractive three bedroom townhouse based on a quiet residential garden complex in the heart of the pleasant village of Chayofa, which is less than five minutes to the main tourist areas of Los Cristianos and Costa Adeje. This property is ideal as a permanent home or winter base. It has spacious internal and external living space, open views to the countryside and coast, and a private underground garage.

Ref: OUT01147
Price: €270,000 (approx. £229,000)

REDUCED!!!

3 BED TOWNHOUSE - PALM MAR

FAMILY HOME!

If you're looking for a spacious good quality family home, we are sure you will like this townhouse! Three bedrooms, two bathrooms, WC, independent fully equipped kitchen and separate utility room, split level lounge & dining area, front and rear garden, roof terrace and private underground garage. Club de Mar is a pleasant residential development in Palm Mar and enjoys an excellent micro-climate!

Ref: PM00108 Previously €385,000
Price: €330,000 (approx. £279,500)

REDUCED!!!

3 BED VILLA - AMARILLA GOLF

VILLA WITH HEATED POOL!

A fantastic opportunity to acquire a three bedroom, three bathroom villa with stunning golf course views and heated private swimming pool. This wonderful property offers a healthy balance of internal and external space. The interior is light, bright and airy and the sunshine floods in from the many windows. The lounge offers an air conditioned environment. Make sure you book a viewing today!

Ref: AMG00523 Previously €435,000
Price: €390,000 (approx. £330,500)

★★★★ BOOST YOUR PROPERTY EXPOSURE ★★★★★

Want to **SELL YOUR PROPERTY?**

We can help optimise your Property's Sales Potential

with a professional **VIDEO PRESENTATION**



FOR MORE DETAILS..

Call

922 714 700

www.TenerifePropertyShop.com



EUROPEAN
PROPERTY
AWARDS
REAL ESTATE

★★★★★

BEST REAL ESTATE
AGENCY SINGLE
OFFICE CANARY
ISLANDS

Tenerife Property Shop S.L.

2019-2020



EUROPEAN
PROPERTY
AWARDS
REAL ESTATE

AWARD WINNER
REAL ESTATE AGENCY
WEBSITE SPAIN

www.tenerifepropertyshop.com
by Tenerife Property Shop S.L.

2019-2020

1 BEDROOM APARTMENT - LOS CRISTIANOS



This beautiful and bright one bedroom apartment has amazing frontline views to the coast and ocean! Based on the popular holiday complex of Paloma Beach in Los Cristianos, this is a perfect property as a holiday home or rental investment. Tastefully renovated and furnished throughout. The complex has a lovely pool area and gardens and is ideally located for all local amenities.

Ref: LC00591

Price: €235,000 (approx. £199,000)

2 BEDROOM DETACHED VILLA WITH POOL - SAN EUGENIO ALTO



A beautiful two bedroom, two bathroom detached villa with private pool located in the prestigious San Eugenio Alto area of Costa Adeje. If you are searching for a holiday home or a permanent residence then this is perfect. Excellent location, panoramic views to the Coast and surrounding area from the pool area and the roof terrace! There is also an impressive double garage under the villa.

Ref: LA01843

Previously €675,000

Price: €595,000 (approx. £504,000)



We don't make promises. We give GUARANTEES!

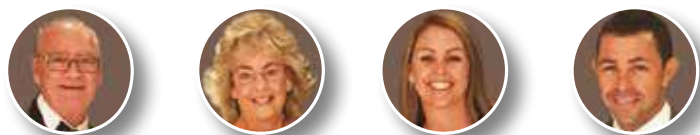

Two generations of a Family Business · Over 30 Years of Experience
Service & Security in your purchase · Professional Indemnity Insurance
20 Year Insured Title Deed Guarantee

☎ 0034 922 714 700 /
0034 922 715 064

From UK: 0845 862 1634

info@tenerifepropertyshop.com

Find us on @TenerifePropertyShop



PALM MAR SALES & RENTALS

**ALL ASPECTS OF PROPERTY MANAGEMENT SALES
& LONG TERM RENTALS**

Tel: 0034 677 623 713 / 0034 671 129 558 • email: info@palmmarsalesandrentals.com • www.palmmarsalesandrentals.com

Palm Mar, Lovely villa



Fully refurbished and furnished, bright and spacious 4 bed, 2 bath villa in the heart of the village. The property enjoys sea views from the solarium and there is an integrated garage.

Price: €470,000

Palm Mar, Laderas de Palm Mar



Spacious 2 bedroom, 2 bathroom duplex apartment with views. The property has a very large solarium. It is sold fully furnished.

Price: €275,000

WE ARE ALWAYS LOOKING FOR NEW PROPERTIES FOR SALE AND LONG TERM RENTAL

Palm Mar, Laderas del Palm Mar



This delightful 1 bed, 1 bath apartment has a sunny aspect and overlooks the lovely pool area. It is bright and spacious throughout and is sold furnished.

Price: €179,995

Palm Mar, Bahia de Los Menceyes



Luxury 1 bed, 2 bath apartment on this prestigious development which is just a short stroll to the sea front. It is sold furnished and the price includes secure underground parking space and a storeroom.

Price: €310,000

Palm Mar, Paraiso del Palmar I



Bright and spacious 1 bed, 1 bath apartment that overlooks the nature reserve. It has wonderful views and the benefit of a large sun terrace upstairs. The property is beautifully presented and is sold fully furnished.

Price: €187,000

Palm Mar, Los Balandros

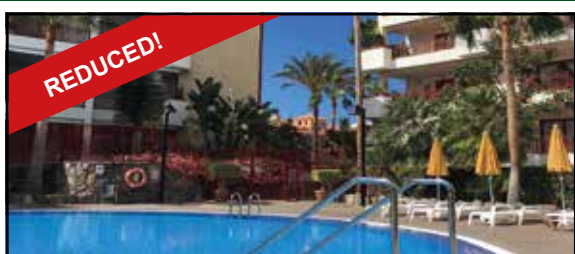

Bright and spacious 1 bed, 1 bath duplex apartment with all day sunshine and views over the 49sqm pool out to La Gomera from the large upper terrace. Sold furnished, the property has the opportunity to utilise the additional upstairs room as a second bedroom.

Price: €189,000

Palm Mar, Punta Rasca



Lovely two bedroom house on this small development in the heart of Palm Mar. There is a bathroom on the first floor and a cloakroom on the ground floor. The price includes a parking space and storeroom and the property is sold fully furnished.

Price: €299,000

Palm Mar, Laderas de Palm Mar



Stunning apartment which has been lovingly refurbished by the current owners to an extremely high standard. Glass windows and blinds have been added to the terrace making an additional lounge. The price includes a very large enclosed garage.

Price: €235,000



TENERIFE PROPERTIES



ENGLISH / ESPAÑOL / FRANÇAIS / ITALIANO - 608 573 443

Контактный телефон для русскоговорящих - 648 525 024

Las Flores, San Eugenio



Studio apartment with south-facing terrace and sea views.

€159,950 Ref: A423

Garden City, San Eugenio

NEW INSTRUCTION



Studio apartment with views to the sea. Popular and central complex.

€179,000 Ref: A434

Malibu Park, San Eugenio Alto

NEW INSTRUCTION



1 bed, 1 bath luxury, penthouse apartment. Sea views.

€195,000 Ref: N1388

Elite Palace, El Duque



Spacious 1 bed, 1 bath apartment in small, exclusive complex. Sold with garage space.

€229,000 Ref: N1366

Santa Maria, Torviscas



1 bed, 1 bath apartment with double terrace and views to the pool and sea.

€230,000 Ref: N1385

Roque del Conde, Torviscas Alto



2 bed, 1 bath apartment with very large terrace on well kept, residential complex. The apartment is south facing and has sun all day on the terrace. This property offers excellent value for money and is sold complete with garage space.

€199,500 Ref: T1177

PROPERTIES ARE IN DEMAND! WE OFFER A FREE VALUATION!

SPECIAL OFFER: ENERGY EFFICIENCY CERTIFICATES PLEASE CALL US FOR MORE INFORMATION!

Club Atlantis Bungalows, San Eugenio



2 bed, 2 bath duplex bungalow located on the front line complex of Club Atlantis Bungalows. This fully refurbished property has been renovated to a high standard in modern style. It has a terrace on the upper level with views to the sea. The complex has 3 pools of which 2 are heated, a pool bar and even a hairdresser's.

€310,000 Ref: T1175

Mareverde, Torviscas



2 bed, 1 bath apartment with good sized terrace and views to the pool.

€215,000 Ref: T1169

Edificio Sonja, Los Menores



2 bed apartment with roof terrace and sea views.

€149,000 Ref: T1184

Castle Harbour, Los Cristianos



2 bed duplex penthouse apartment with views to the pool.

€210,000 Ref: T1163

Charco del Valle, Los Menores

NEW INSTRUCTION



3 bed, 2 bath townhouse with garden, roof terrace, garage and sea views.

€280,000 Ref: I1312

La Quinta, Amarilla Golf



4 bed, 3 bath Canarian style villa situated next to golf course and sea.

€495,000 Ref: I1311

 Translators available for any other languages.



Tel: 922 724 110 • Sales: Lynne: 699 250 870 Rachel: 608 573 443
 Local 3, C.C. Palo Blanco, San Eugenio, Adeje 38660, Playa de las Americas
 www.tenerifeproperties.net • lynne@tenerifeproperties.net



SOUTH

Avda de Espana 5,
CC Terranova local
308 y 309,
COSTA ADEJE

NORTH

Avda. Marques Villanueva
del Prado 44,
PUERTO DE LA CRUZ



Mobile: (+34) 689 770 170



After 3 successful years in the North, we are proud to have opened our second office in Costa Adeje!



Costa del Silencio

3 apartments and commercial surface. Motivated seller.

€495,000 Ref: A6715B



Arafo

Lovely country house with garden.

€280,000 Ref: C6280C



Los Gigantes

2 bedroom, excellent location.

€369,000 Ref: C6375A



Los Gigantes

2 bedroom apartment with amazing views.

€159,000 Ref: S6159A



Adeje

3 bedroom detached villa.

€398,000 Ref: C6409V



Costa Adeje

High end exclusive villa, 4 en suite bedrooms.

€P.O.A Ref: C61680V



Amarilla Golf

Privileged location, 5 bedrooms.

€945,000 Ref: R6945V



Costa del Silencio

Modern 7 bedroom villa.

€499,000 Ref: I6585V



Amarilla Golf

Villa overlooking the city.

€695,000 Ref: R6695V

Tel: 922 719 643
 Fax: 922 781523
 Mobile: 607 933 052
 Mobile: 625 950 517



Calle Tagara,
 Jardin Botanico
 Local 8
 ADEJE















OPPORTUNITY OF THE MONTH!

ALCALA	LA ESCALONA	PLAYA DE LA ARENA	EL ROQUE (SAN MIGUEL)
			
Ref: 1132 €380,000	Ref: 939 €198,000	Ref: 1096 €210,000	Ref: 1127 €290,000

**We cover the whole of the South ...
 That's why we have two Offices (in Adeje and Alcala!)**

**PROPERTIES WANTED FOR RENT
 CLIENTS WAITING!**

					
Ref: 1036 €649,000	Ref: 756 €560,000	Ref: 984 €330,000	Ref: 989 €578,000	Ref: 1098 €500,000	Ref: 1128 €524,000
					
Ref: 1094 €179,000	Ref: 1074 €190,000	Ref: 1114 €130,000	Ref: 1051 €310,000	Ref: 1123 €130,000	Ref: 1122 €140,000

NEW

Townhouse in La Caleta



- Mirador del Golf, La Caleta
- 3 bedrooms, 3 bathrooms
- Golf and Sea Views
- Ref: D1221
- Price: 699,000€

This beautifully appointed townhouse is located in the exclusive gated development Mirador del Golf just a few minutes away from La Caleta. The property offers three bedrooms all with fitted wardrobes, three bathrooms, a fully equipped kitchen that leads to a light and airy living space.

REDUCED

Apartment in Callao Salvaje



- Sueno Azul, Callao Salvaje
- 1 bedrooms, 1 bathrooms
- Easy Renting
- Ref: D1082
- Price: 139,000€

This one bedroom apartment is in the popular tourist complex Sueno Azul in Callao Salvaje. It comprises 58m2 of living space with one bedroom, one bathroom, and a lovely open style kitchen leading to the living room, ending to a nice terrace 10m2 with lateral sea views.

✉ frina@tenerife-property.com

☎ +34 683 479 245 ☎ +34 617 29 48 03

🌐 www.tenerife-property.com

🏠 CC Puerto Colón, 1st Floor, local 213, 38660 Adeje

FRINA Tenerife S.L.
Business & Property Agency



MK PROPERTY AND MONEY EXCHANGE

C.C. CITY CENTER - L22 PLAYA DE LAS AMERICAS - ARONA 38660 - TENERIFE

Tel: 922 751 693 / Mob: 630 994 991 - Email: marykilmartin333@gmail.com



Callao Salvaje, Mariben



Beautifully furnished 2 bed, 2 bath (+WC) semi-detached townhouse with large lounge leading to a 40sqm sunny terrace. Large garage and storeroom included.

Bargain Price: €299.000

Las Americas, Parque Santiago



Luxury studio on sought after sea front complex. Totally reformed and furnished to a very high standard. Sea and mountain views!

Price: €200,000

Los Cristianos, Victoria Court II



Fabulous, fully furnished 1 bed, 1 bath apartment located just 300 meters from the beach. In well-run complex with pool and amenities.

Price: €299,000

Adeje, Jardin Botanico



Superb 3 bedroom (both double), 2 bathroom townhouse on sought after complex with lovely pool area. The property has an independent kitchen, and large garage and storeroom. An ideal family home.

Price: €240,000

Las Americas, Fabulous apartment



Fabulous, fully furnished 1 bed, 1 bath apartment located just 300 meters from the beach. In well-run complex with pool and amenities.

Price: €175,000

Palm Mar, Las Olas



Luxurious, beautifully furnished 2 bedroom, 2 bathroom apartment in sought after location with lovely pool area. This bright and spacious property is in a great location and has a garage and storeroom.

Price: €289,000

Callao Salvaje, Mariben



Beautiful 2 bedroom, 2 bathroom property on this superb community with heated pools, tennis courts and children's play area.

Price: €235,000

Playa Fanabe, Villas de Fanabe



Location, Location, Location! Lovely 1 bedroom, 1 bathroom penthouse apartment only 300 metres from the beach. A bright and spacious, sunny property with pool views. Great value.

Price: €170,000

ISLAND ESTATES

EST. 1984

CALL: +34 922 790767
 UK FREEPHONE: 0800 802 1669
 EMAIL: INFO@ISLANDESTATES.ES
 WWW.ISLANDESTATES.ES

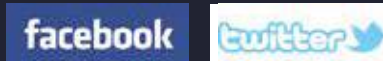

GREEN PARK, Golf del Sur

BARGAIN!



Ref: 429-A1

2 bed apartment on the top floor of this holiday community with 3 pools. Large double bedroom and additional bedroom area, lounge and kitchenette, bathroom and private terrace with pool views.

2 bed, 1 bath 112.000€

PARAISO DEL SUR, Playa Paraiso

NEW LISTING!



Ref: 580-S

Furnished and refurbished top floor studio with terrace and stunning sea views. This is a really amazing opportunity to own a coast property in Tenerife. The property is well located in a resort with swimming pool. Great local amenities. An ideal bolt hole in the sun. Viewing highly recommended.

0 bed, 1 bath 115.000€

LOS DIAMANTES, LOS CRISTIANOS

NEW LISTING



Ref: 549-A1

Well presented, fully furnished 1 bed, 1 bath ground floor apartment with pool views. The property has a double bedroom, refurbished bathroom, new kitchen and lounge, sunny terrace and heated community with pool. Viewing highly recommended.

1 bed, 1 bath 137.000€

LAS FLORITAS, Las Americas

NEW LISTING!



Ref: 562-A2

Fully furnished, 1 bed, 1 bath part-refurbished apartment with sunny terraces, and pool views. Well located, close to amenities and the coast. Fitted and equipped kitchen, fitted wardrobes. Excellent community with pools, and gardens.

1 bed, 1 bath 175.000€

FAIRWAYS CLUB, Amarilla Golf

EXCLUSIVE PROMOTION!



Ref: 429-A1

Available now, and priced to sell, a selection of spacious 1- and 2-bedroom properties available for sale in this popular and well-run community bordering Amarilla Golf course. All properties have great outside space and enjoy beautiful tropical gardens round the recently-renovated heated pool. Each property has an exceptional outlook with garden, golf or mountain views. Contact us today for a viewing. info@islandestates.es, (0034) 922 790 767 or (0034) 677 030 033.

FROM JUST 112.000€

SAND CLUB, GOLF DEL SUR

NEW LISTING



Ref: 583-A1

Fully refurbished one bedroom apartment well located in Sand Club, close to the San Blas area of Golf del Sur. Modern, and brand new throughout this spacious property offers double bedroom, American style kitchen, bathroom, and terrace / garden. Viewing recommended.

1 bed, 1 bath 136.000€

BELLAMAR, Bahia del Duque

NEW LISTING!



Ref: 574-A2

Amazing offer: 2 bed, 2 bath apartment with large lounge, independent fitted kitchen and front and back terraces totaling 65sqm. Car port and communal facilities including pool and gardens. Viewing recommended.

2 bed, 2 bath 280.000€

SAN RAFAEL, Playa de las Americas

BARGAIN!



Ref: 455-TH3

Investment opportunity. 3 bed, 2 bath double unit well located in this central resort close to the beach. With many other properties undergoing upgrades as well as in the community, the time is right for this great opportunity. Viewing recommended.

3 bed, 3 bath 180.000€

PALM GARDENS, Amarilla Golf

NEW LISTING!



Ref: 578-A2

Large 2 bed, 2 bath penthouse apartment with sea, mountain and golf views. Offered unfurnished and comprising semi-independent fitted and equipped kitchen, lounge with terrace and large private roof terrace. Garage space. Community with pool.

2 bed, 2 bath 295.000€

PIEDRA HINCADA, Guia de Isora

NEW LISTING!



Ref: 579-TH3

Very well presented 3 bed, 2 bath townhouse in an excellent location in popular village close to Abama Golf Resort in the south of Tenerife. This large property has a kitchen/diner and lounge, and basement with garage. Viewing is highly recommended. Price negotiable.

3 bed, 2 bath 265.000€

EUCALYPTUS, Los Cristianos

SPACIOUS!



Ref: 560-A2

Recently refurbished 2 bed, 1 bath apartment with stunning views over the village to the sea. Offering 2 double bedrooms, bathroom, American style kitchen and lounge dining room. Large private sunny terrace.

2 bed, 1 bath 239.400€

YOU'LL FIND OUR OFFICE ACROSS FROM THE FOOTBALL STADIUM IN PLAYA DE LAS AMERICAS

ADVERTISE YOUR PROPERTY WITH US AND SEE YOUR PROPERTY PROMOTED WITH RIGHTMOVE AND ZOOPLA IN THE UK AND KYERO ACROSS EUROPE.

Local 1, Las Floritas, Avenida Arquitecto Gomez Cuesta 16, Playa de las Americas, Arona 38660, Santa Cruz de Tenerife





CLEAR BLUE SKIES GROUP SL
INTERNATIONAL ESTATE AGENTS

3 2 Ref: 7715

PLAYA DEL DUQUE

Penthouse **€470,000**

2 2 Ref: 7651

ABAMA

Luxury Garden Apartment **€745,000**

3 2 Ref: 7700

ALCALA

Apartment **€159,000**

2 2 Ref: 7692

PARQUE DE LA REINA

Apartment **€179,950**

3 3 Ref: 7675

GOLF DEL SUR

Townhouse **€289,000**

1 1 Ref: 7674

LOS CRISTIANOS

Apartment **€156,950**

3 3 Ref: 7669

PALM MAR

Luxury Duplex **€890,000**

5 4 Ref: 7436

CALLAO SALVAJE

Villa **€695,000**

4 2 + WC Ref: 7428

EL MADRONAL

Townhouse **€460,000**

1 1 Ref: 7049

EL MADRONAL

Apartment **€170,000**

6 6 Ref: 6913

SAN EUGENIO ALTO

Villa **€875,000**

5 3 Ref: 6697

GUIA DE ISORA

Village House **€399,000**



CLEAR BLUE SKIES GROUP SL
INTERNATIONAL ESTATE AGENTS

G 2 1

Ref: 7518

TORVISCAS ALTO

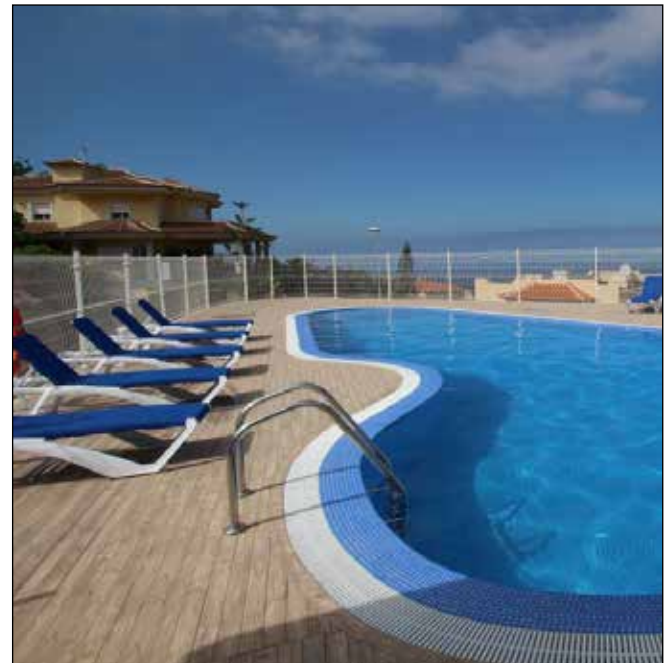

An immaculate two bedroom apartment located in the ever popular Torviscas Alto area. Tastefully decorated, this apartment has been totally refurbished in a modern style and comprises of two double bedrooms, shower room, fully fitted & equipped open plan kitchen, bright lounge and spacious terrace with panoramic coastal & mountain views. Communal pool and lift to all floors. Viewing is highly recommended.

Apartment €174,000

We are looking for properties in the following complexes:- Mareverde, Orlando, Parque Royale and Vilaflor. If you are thinking of selling please call us today!

G 2 1

Ref: 7698

LOS CRISTIANOS



This spacious two bedroom apartment benefits from a top floor position and boasts two sunny terraces with sea, mountain and town views. The living area consists of an American style kitchen, lounge with dining area and a bathroom. Both bedrooms are generous in size and have access to a private terrace. San Marino is a popular and well established complex in the heart of Los Cristianos, close to the beach and with a multitude of bars, shops and restaurants on the doorstep, a great location! Lift access, communal parking and a heated swimming pool, must be seen.



Apartment €299,000



Avda Londres 1, Sur y Sol, Local 1
Los Cristianos, Arona 38650

Office: 922 797 438 / 922 751 587
Mobile: (00 34) 673 778 700

www.tenerifeislandrentals.com
info@tenerifeislandrentals.com



Tenerife Island Rentals & Buy Tenerife

Sales

RUSTIC PROPERTY, GUIMAR



Typical Canarian property with three bedrooms, bathroom, living room and independent kitchen built on a plot of 6000m2. This property is habitable but does need some modernising. There are several outbuildings and a very large storeroom that could all be converted into extra living space. Part of the land is classified as urban meaning it can be built on. Large water reservoir that provides water to the main house and for watering the grounds. Uninterrupted sea and mountain views located in a very tranquil location.

Ref: MAS0549

€140,000

SUR Y SOL, LOS CRISTIANOS



Ground floor one bedroom apartment which has been converted to allow for a second bedroom. Living room with American style kitchen, bathroom with walk in shower and front and rear terraces. Fantastic community pool area in a well-kept, secure complex. Located just 80m to the Los Cristianos beach front with no hills. Ideal holiday home or investment property.

Ref: AP0546

€173,000

TIGAIGA II, PARQUE DE LA REINA



Two bedroom apartment located on the first floor with garden views. Large living dining room with enclosed balcony, independent fitted kitchen and washing room, two double bedrooms the master with en suite and further family bathroom, both bedrooms have fitted wardrobes. The property also comes with a parking space and large storeroom with lift access from the garage to the property. Community swimming pool. This is a popular area just five minutes from Los Cristianos.

Ref: AP0521

€152,000

MIRADOR LA GOMERA, CALLAO SALVAJE



This property has two good sized bedrooms and bathroom, large living room and very large terrace with pool views. There is also a large independent kitchen. The integrated garage has been converted into additional living space with a bedroom, living area and bathroom however the garage door is still in place should the new owner want to convert it back to its original use. Fantastic community pool and views to La Gomera.

Ref: AP0535

€295,000

SOTAVENTO, LA TEJITA



Very large luxury one bedroom ground floor property with very large terrace for outdoor living. The apartment has a beautiful chef style kitchen with high spec appliances, bathroom and living room. The property comes with a private parking space and storage facilities. Community swimming pool, gardens and padel courts. This is just a short walk to the beach and the La Tejita street market.

Ref: AP0500

€218,000

LUXURY VILLA, EL GALEON



Recently renovated five bedroom five bathroom luxury property split over three levels. Open plan living room with fantastic kitchen area with top of the range appliances and access to the terrace with private pool and uninterrupted views of the coast and La Gomera. On the upper floor there are two large bedrooms with dressing areas and en suite bathrooms and a terrace from both bedrooms. The basement level houses a cinema room, gym or games room and three bedrooms all with en suite bathrooms. Garage area that can house several cars. This is a fabulous property renovated to a very high standard.

Ref: CHA0525

€1,395,000

Avda Londres 1, Sur y Sol, Local 1
Los Cristianos, Arona 38650

Office: 922 797 438 / 922 751 587
Mobile: (00 34) 673 778 700

www.tenerifeislandrentals.com
info@tenerifeislandrentals.com



Tenerife Island Rentals & Buy Tenerife

Sales

EL MIRADOR, LOS CRISTIANOS



- 55m2 built
- Double bedroom with fitted wardrobes
- Large living room
- American style kitchen
- Balcony
- Roof terrace
- Community pool



Ref: AP0547

€239,995

MONCAYO, PARQUE DE LA REINA



- 79m2 built
- 2 double bedrooms
- 2 bathrooms
- Large living room
- Separate fitted kitchen
- Community pool
- Parking & storeroom



Ref: AP0269

€130,000

T: (0034) 922 732862
 M:(0034) 683 190 977
 info@rdproptiestenerife.com

Calle Luis Alvarez Cruz,
 nº6, Edf Bahia Azul, Local 8C
 Las Galletas - Next to post office



BUSINESS - CAMPING SITE WITH WITH LUXURY CHALET



BUSINESS FOR SALE!! ming pool on site.
 15.000sqm plot! with The whole plot is very
 190 sqm house! well maintained and in a
 All plans and papers in fantastic location, close
 order to turn this amaz- to the surfer's para-
 ing piece of land into a dise El Medano and the
 great "Glamping" site south airport (but far
 (glamorous camping). enough away that you
 There is already a are never disturbed by
 one- bedroom house, any noise).
 a bar and small swim- From this quiet spot

you can enjoy an un-
 disturbed 360° view
 from the coast, to the
 enchanting Red Moun-
 tain and up the majestic
 Mount Teide volcano.

**REF: AO96-
 CB PRICE:
 €690,000**





Inmobiliaria - Estate Agent

Homes & Away



+34 922 737 044 info@homesandaway.com

Local 31, CC San Blas, GOLF DEL SUR, Tenerife www.homesandaway.com

SALES

GOLF DEL SUR



Well-appointed, home from home, converted 2 bed, 2 bath house on sought after residential complex. Front and rear gardens. Room for expansion.

£197,500 Sterling

AMARILLA GOLF



3 bed, 2 bath villa with private pool and driveway situated in popular residential area, close to the sea. Ideal family home.

£315,000 Sterling

GOLF DEL SUR



1 bed, 1 bath top floor apartment in excellent condition situated on popular holiday complex with large west-facing balcony offering sea, golf course and mountains views.

£108,000 Sterling

AMARILLA GOLF

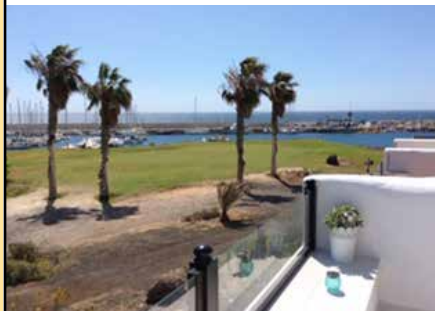

Immaculate and contemporary top floor 1 bed apartment overlooking San Miguel Marina.

€159,500

GOLF DEL SUR



Top floor, spacious, south-facing 2 bed, 2 bath apartment with large terrace with good views. Close to the pool and elevator on residential community. Secure parking space included.

£199,000 Sterling

GOLF DEL SUR



Light, bright and well-presented 1 bed, 2 bath apartment with large sunny terrace on popular complex. Pool and bowling green views.

£139,000 Sterling

RENTALS

GOLF DEL SUR



Nicely furnished 3 bed, 3 bath south-facing penthouse apartment with 2 terraces giving all day sun. Parking space included.

€950 per month

COSTA DEL SILENCIO



Lovely 2 bed, 1 bath semi-furnished apartment on well-maintained complex.

€700 per month

GOLF DEL SUR



Well-appointed, top floor, 1 bed apartment with terrace giving afternoon sun. WiFi included.

€750 per month

GOLF DEL SUR



3 bed, 2 bath apartment on 2nd floor of complex with lift and international bowling green. Close to all amenities. Inc. €75 for electricity.

€1,050 per month

Residential Property Sales

Over €350,000

Los Menores,

€1,400,000

8 bed · Situated just outside the tourist area of Costa Adeje, but only 5 minutes drive to all the shops and amenities, this fantastic property comprises of 8 double bedrooms, and 6 bathrooms. The original house was divided in 2, so you have 2 spacious living rooms and 2 fully equipped kitchens, all granting access to big terraces. There is a lot of outside space... For full information see website or contact:

Ref: 5100 | Clear Blue Skies SL | 922 714 772

El Roque,

€1,400,000

3 bed · This beautiful villa enjoys of a great location with panoramic coastal and mountain views. The property comprises of a villa with private pool and project for a restaurant with all facilities in place and ample parking for clients. The villa has been built in one level and comprises of 2 double bedrooms (master en suite and with dressing room), one single... For full information see website or contact:

Ref: 6196 | Clear Blue Skies SL | 922 714 772

Torviscas Alto, Villa

€1,350,000

3 bed · Off plan opportunity to purchase a spacious contemporary villa with private pool in the quiet Roque del Conde area of Torviscas. The villa forms part of the Villa16 project comprising of 16 detached luxury villas enjoying breath-taking views over Costa Adeje. A modern living space distributed over 2 floors and offering a fully equipped open plan kitchen a... For full information see website or contact:

Ref: 7638 | Clear Blue Skies SL | 922 714 772

Abama Golf Resort, Villa

€1,285,000

2 bed · A limited collection of 12 magnificent detached homes, each with private pool deck, Villas del Tennis offers the utmost in privacy and the most breathtaking views. Adjacent to the Annabel Croft Tennis Academy, encircled by the brilliant Dave Thomas golf course, Villas del Tennis will appeal to those who demand the best-of-the-best. Some villas comprise of t... For full information see website or contact:

Ref: 7105 | Clear Blue Skies SL | 922 714 772

Los Cristianos, Villa

€1,180,000

4 bed · An immaculate, exclusive and top quality villa in a recently completed residential complex. The villa has been redesigned by its sole owner, converting one of the dining rooms into a separate apartment with its separate kitchen, living room, bedroom and separate bathroom. What makes this setup, perfect for guests or friends. The property is sold fully fur... For full information see website or

contact:

Ref: 7487 | Clear Blue Skies SL | 922 714 772

Palm Mar, Detached villa

€995,000

Modern 4 bedroom villa on front line in Palm Mar.
Tenerife Properties Ref: 11265
Tel: 699 250 870 / 608 573 443

San Eugenio, Jardin Tropical

€985,000

2 bedroom luxury apartment in front line complex.
Tenerife Properties Ref: 11157
Tel: 699 250 870 / 608 573 443

Detached villa, Villaflor

Piano Lessons

Learn at your own pace with a relaxed, friendly teacher to guide and support you.

Custom made lessons to suit all levels and musical interests.

I am experienced in preparing students for ABRSM Piano Exams.

Call Louise 686 014 355
www.pianointenerife.eu

KEYBOARDS FOR HIRE

Bungalows

€970,000

3 bedroom villa plus studio apartment.
Tenerife Properties Ref: 11305
Tel: 699 250 870 / 608 573 443

Palm Mar,

€950,000

4 bed · Spacious villa with 2 double bedrooms, really large living area, bathroom and shower room. Completely equipped kitchen, terraces with awnings and electric shutters on all the windows. The property has two separate apartments, one of which has two bedrooms (one with en suite bathroom), an independent kitchen, 2 bathrooms, solar heated indoor pool and a terra... For full information see website or contact:

Ref: 5490 | Clear Blue Skies SL | 922 714 772

Arona,

€895,000

5 bed · Luxury Country-Villa with Pool, Bodega and Panoramic Sea View.
Ref: 20140396 | A1 Real Estate & Property Consultants | 922 729395

Armenime,

€888,000

MBS Physiotherapy Tel: 638 918 684

- ✓ Therapeutic Massage
- ✓ General Physiotherapy
- ✓ Cervical Pain
- ✓ Neurological Physiotherapy
- ✓ Bobath Method
- ✓ Perfetti Method
- ✓ Kinesiotaping
- ✓ Neromuscular Bandage
- ✓ Dry Needling
- ✓ Neurodynamic Techniques
- ✓ Functional Recovery
- ✓ Electrotherapy

Ma Milagros Sancho Martin, Col. No: 117 Carretera General Guaza, No 9, GUAZA

Monday - Friday 9am - 1pm, 3pm - 6pm

3 bed · This fantastic villa is situated near the GOLF COURSE of Adeje. Set on 3 floors with unobstructed views. 2 beds with dressing room, 2 baths, 1 toilet, 2 living-lounges (fireside), Library, ample hall, large kitchen with dining, patio canario, garage, pool and much more. Such an exclusive

Galletas. On the ground floor of this property there is a large indoor barbecue area with kitchen, wash room and WC with access to the wrap around terrace. There is a small courtyard for outdoor dining that leads to a self contained apartment which can also be

property does not come often on the market. Sold furnished.

Ref: 86-330 | Dr Stange International | 922 793271

San Eugenio Alto, Caldera del Rey

€875,000

3 bedroom modern villa with pool.
Tenerife Properties Ref: 11300
Tel: 699 250 870 / 608 573 443

Torviscas Alto,

€845,000

4 bed · Location: Residential Area ♦ Views: Sea, Mountain ♦ Rooms: Hall/Entrance, Independent Kitchen, Lounge

accessed from the m... For full information see website or contact:

Ref: CHA0441 | Tenerife Island Rentals and Buy Tenerife | 922 7510728

Torviscas Alto, Villa

€695,000

4 bed · Location: Central, Close to amenities, Popular urbanisation, Residential Area ♦ Close to: Medical Facilities, Coast, Restaurants/Bars/Cafes, Transport ♦ Views: Sea, Mountain, La Gomera ♦ Rooms: Hall/Entrance, Store rooms, Independent Kitchen, Dining room, Lounge and dining area, Attic, Fitted wardrobes, Dressing room, Bathroom, Family Bathroom, Office, ... For full information see website or contact:

Ref: 4V3396 | Property Alliance SL | 922 777 747

Torviscas Alto,

€695,000

4 bed · Offering delightful views this detached Andalusian style villa is situated in a prestigious area of San Eugenio Alto. Spread over 3 floors the property boasts a large living area comprising of an independent fully fitted and equipped kitchen, utility area, lounge with dining area and shower room on the ground floor, upstairs there are 3 double bedrooms (o... For full

the second phase of development which shall be divided into three terraces, each containing a selectio... For full information see website or contact:

Ref: 5484 | Clear Blue Skies SL | 922 714 772

Adeje Town, Rustic House

€610,000

2 bed · A beautiful rustic house on a plot of 47,000m2 in the village of Ifonche, in Adeje. On the land there are 5 caves overlooking the sea and the islands of La Gomera, El Hierro and La Palma. The property has all the equipment to make wine from the vineyards and various fruit trees and gardens. It has an irrigation system already piped in. This finca is situa... For full information see website or contact:

Ref: 6318 | Clear Blue Skies SL | 922 714 772

San Eugenio Alto,

€600,000

5 bed · Location: Residential Area, Quiet location ♦ Views: Sea, La Gomera ♦ Rooms: Utility room, Fitted wardrobes, Lounge and dining area, Independent Kitchen, Hall/Entrance ♦ Quality: Spacious, Rustic style, Good condition, Furnished ♦ Features: Security shutters, Security system, Satellite system, Private swimming pool, Heated

Ensuite, Bathroom, Office ♦ Quality: Furnished, Charming property, Rustic style, Spacious... For full information see website or contact:

Ref: 3V3003 | Property Alliance SL | 922 777 747

Golf del Sur,

€595,000

4 bed · Villa on one level (400m2) with 4 bedrooms 3 bathrooms, 2 living rooms, very large, heated indoor pool, gardens and much more at a bargain price.

Ref: Alamos Park | MK Properties | 922 751 / 630 994991

Torviscas Alto,

€595,000

4 bed · Superb family villa on four levels in an exclusive, sought after area of Torviscas Alto with breathtaking, panoramic coastal views which must be seen to be appreciated. This well-kept property pays great attention to detail in both its large fully-fitted kitchen and stylish lounge which leads onto the patio with private pool. The master bedroom is en suite... For full information see website or contact:

Ref: 1020 | Clear Blue Skies SL | 922 714 772

Callao Salvaje,

€595,000

3 bed · Location: Quiet location ♦ Close to: Transport ♦ Views: Pool, La Gomera, Sea, Garden ♦ Rooms: W. C., Bathroom, Fitted wardrobes, American Style Kitchen, Store rooms, Hall/Entrance ♦ Quality: Newly built, Modern, Good condition, Unfurnished, Charming property, Quality construction ♦ Features: Private swimming pool, Double Glazing ♦ Outside: Garden, Sunny... For full information see website or contact:

Ref: 3V3306 | Property Alliance SL | 922 777 747

Playa de la Arena,

€580,000

3 bed · An immaculate 3 bedrooms independent villa in Playa de la Arena. With stunning views of the ocean and the neighbouring island of La Gomera. The villa comprises of 3 bedrooms, 3 bathrooms and separate kitchen, spacious lounge from which you can access a fantastic patio and pool area that is perfect for barbecues and entertaining. The property also has a la... For full information see website or contact:

Ref: 6984 | Clear Blue Skies SL | 922 714 772

San Eugenio, Parque San Eugenio

€565,000

4 bedroom, 2 bathroom bungalow with garden in central location.

Tenerife Properties Ref: 11309
Tel: 699 250 870 / 608 573 443

Aguilas del Teide,

€562,000

3 bed · Beautiful 3 bedroom, all with fitted wardrobes, 3 bathroom (all en-suite) + w. c., fully furnished Villa for sale in popular area in the south of Tenerife. There is a large fully fitted kitchen and dining room, living room, wooden floors

Studio 4 Decor

NEW STORE NOW OPEN!

ACROSS THE ROAD FROM OUR OLD ONE
IN LOS ABRIGOS

SEE OUR MAIN ADVERT ON PAGE 34

information see website or contact:

Ref: 7147 | Clear Blue Skies SL | 922 714 772

San Eugenio Alto,

€690,000

3 bed · Luxury house with 3 bedrooms 3 bathrooms, independent kitchen, bright lounge, large private garden, terrace and large Jacuzzi. Spacious office and storage. Garage for 2 cars. Panoramic views to coast.
Ref: Sunil | MK Properties | 922 751 / 630 994991

Los Cristianos,

€630,000

3 bed · Fully furnished 3 bed, 3 bath townhouse near the sea front with pool and gardens. The property measures: Int. 200sqm., Ext. 150sqm.
Ref: 3TH2896 | Property Alliance SL | 922 777 747

Abama Golf Resort,

€615,000

2 bed · The Terraces of Abama is the ultimate luxury development in the Canary Islands. It has been especially designed and created offering the concept of true exclusivity as is befitting of the luxury Abama brand. Clear Blue skies are happy to present for sale

swimming pool, Air conditioning... For full information see website or contact:

Ref: 5V3128 | Property Alliance SL | 922 777 747

Golf del Sur,

€599,000

3 bed · Immaculate villa on the exclusive Alamos Park development of Golf del Sur. This spacious villa offers bungalow style living and consists of a separate fully fitted kitchen, spacious lounge diner and large conservatory/2nd lounge. The master bedroom benefits from fitted wardrobes, a large en-suite bathroom with sauna and Jacuzzi unit, the second bedroom al... For full information see website or contact:

Ref: 5984 | Clear Blue Skies SL | 922 714 772

Golf del Sur,

€599,000

3 bed · Location: Close to the coast, Popular urbanisation ♦ Close to: Airport, Coast, Restaurants/Bars/Cafes, Medical Facilities, Shops, Transport ♦ Views: Mountain, Sea ♦ Rooms: Hall/Entrance, Independent Kitchen, Lounge and dining area, Fitted wardrobes, Family Bathroom,



VYM CANARIAS – May 20

Luxury Villa in El Galeon



Luxury and fully reformed villa with panoramic views in prestigious area. 5 bedrooms, 5 bathrooms, guest toilet, large living room, kitchen, terrace and pool. Garage for 2 cars.

€1,395,000

Ref: VS6675D

Villa in La Caleta Golf



Modern villa with a unique design and high quality on the plot of land of 2.536m2. Living area 286m2, located on two floors and 4 bedrooms, each with its own bathroom. Private pool and garden.

€2,800,000

Ref: VS6859DN

Balcon de los Gigantes, Los Gigantes



Apartment with fantastic sea views. 1 bedroom, bathroom, living room with kitchen and great terrace.

€155,000

Ref: VS6742

Torviscas Alto, Balcon del Atlantico



The apartment has 1 bedroom with wardrobe, a bathroom, an open-plan kitchen with a living room and a terrace. The complex with a swimming pool.

€175,000

Ref: VS6269D

Las Americas, Playa Honda



Apartment in the center of Las Americas on the second floor. It consists of 1 bedroom with fitted wardrobe, open plan kitchen with a living room and a terrace.

€169,000

Ref: VS6857D

La Caleta, Magnolia Golf Resort



Luxury apartment with a large terrace and a garden with mountain and ocean view. 3 bedrooms, 2 bathrooms, open-plan kitchen with a living room. Fully furnished.

€650,000

Ref: VS6826D

Sueño Azul, Callao Salvaje



2 bedroom apartment with fantastic ocean view. Living area 106m2, terrace 22m2, garden 51m2. Great location.

€320,000

Ref: VS6755D

Viña del Mar, Playa de las Americas



Bungalow with 1 bedroom, bathroom, living room and kitchen. Living area 55m2. Pool and parking in the complex. Ideal investment.

€190,000

Ref: VS6590D

Playa Paraiso, Ocean Garden



Luxury apartment in new complex with 2 bedrooms, 2 bathrooms, parking space and beautiful terrace. Living area 65m2, terrace 13m2. Pool in the complex.

€270,000

Ref: VS5571D

Agua Viva, Callao Salvaje



Front line apartment near the beach. Large terrace with sea view. 2 bedrooms, 1 bathroom, living area and kitchen. Swimming pool in the complex.

€169,000

Ref: VS6836D

Playa Paraiso, Sol Paraiso



Excellent 2 bedroom apartment. Third floor. This apartment has two bedrooms with fitted wardrobes, a full bathroom, an American-style kitchen, a living room and a terrace.

€171,000

Ref: VS6846D

Sand Club, Golf del Sur



Reformed apartment with a garden. 1 bedroom, 1 bathroom, open-plan kitchen, living room and terrace with a garden. Swimming pool in the complex. Great location.

€142,800

Ref: VS6827D

Principal Office: C.C. Victoria Tenerife Sur, Local 1, C/ Republica de Panama, 1, LAS AMERICAS, 38660, Adeje



Tel: 922 787 210 / 635 881 888

Email: info@vymcanarias.com · Web: www.tenerifecenter.com

Playa Paraiso: 922 713 395, email: playaparaíso@vymcanarias.com

Callao Salvaje: 922 717 663, email: callaosalvaje@vymcanarias.com

San Eugenio: 922 715 185, email: saneugenio@vymcanarias.com

Golf del Sur: 922 455 874, email: golfdelsur@vymcanarias.com

El Duque: 922 547 611, email: elduque@vymcanarias.com



throughout with its own private heated swimming pool. The Villa is air-conditioned and has been completely renovated. T... For full information see website or contact:

Ref: S-03 1279 | Tenerife Prime Property | 922 703 725

Puerto Colon, Club Atlantis Bungalows

€550,000

2 bedroom, 2 bathroom duplex bungalow on frontline.

Tenerife Properties Ref: T1172 Tel: 699 250 870 / 608 573 443

Palm Mar, Townhouse

€550,000

3 bed · A totally renovated home just a short stroll from the sea. This semi-detached property is finished in a bright modern style with the living area on one floor, comprising of three good size bedrooms, master with fitted wardrobes and en-suite shower room, guest shower room, fully fitted & equipped kitchen with all new appliances and a spacious lounge. Under... For full information see website or contact:

Ref: 7513 | Clear Blue Skies SL | 922 714 772

San Eugenio Alto, Mirador del Sur

€550,000

3 bedroom villa with pool.

Tenerife Properties Ref: I1234 Tel: 699 250 870 / 608 573 443

Golf del Sur,

€549,000

4 bed · Beautiful 3/4 bedroom villa for sale in Alamos Parque on Golf del Sur. Situated on a large 1000 m2 plot, this villa has 250 m2 of living space. Good sized bedrooms, a large lounge and dining area, kitchen, utility room. Great outside space with large garden area, swimming pool and terraces for BBQ and entertaining. Driveway for several cars. Sold unfu... For full information see website or contact:

Ref: V406-BP | Tenerife Belfin Properties | 692 146808

El Cho,

€540,000

4 bed · ♦ Location: Residential Area, Quiet location ♦ Close to: Schools, Transport, Airport ♦ Views: Mountain ♦ Rooms: Games room, Hall/Entrance, Independent Kitchen, Lounge and dining area, Fitted wardrobes, Bathroom, Family Bathroom ♦ Quality: Spacious, Rustic style, Well presented, Immaculate condition, Part furnished, Quality construction, Charming property ... For full information see website or contact:

Ref: 4V3241 | Property Alliance SL | 922 777 747

Golf del Sur,

€525,000

4 bed · Large family villa in the exclusive Alamos Park area of Golf Del Sur. Standing on a plot of 1000m2 this beautiful villa is built to a high specification and comprises of a bright entrance hall leading to a superb independent fully fitted and equipped kitchen, a large lounge with 2 sets of patio doors leading onto a gorgeous terrace/garden area. Opposite t... For full information see website or contact:

Ref: 7144 | Clear Blue Skies SL | 922 714 772

El Medano,

€525,000

4 bed · 4 bed, 3 bath semi-detached house with sea view in a popular area. Integrated garage.

Ref: 1763 | Homes &

Away | 922 737 044

Las Americas,

€525,000

2 bed · Fully furnished 2 bed, 2 bath apartment in touristic complex with pool, gardens and satellite TV. The property measures: Int. 76sqm., Ext. 24sqm.

Ref: 2D2762 | Property Alliance SL | 922 777 747

El Madronal,

€499,000

4 bed · Fantastic modern style villa in El Madronal. The villa has 4 bedroom and 3

information see website or contact:

Ref: 85-308 | Dr Stange International | 922 793271

Vera de Erques, Rural House

€490,000

4 bedroom rural house with garden.

Tenerife Properties Ref: I1304 Tel: 699 250 870 / 608 573 443

El Galeon,

€475,000

5 bed · ♦ Location: Close to amenities, Gated community, Popular urbanisation, Residential Area ♦ Close to:

FRINA Tenerife

business & property agent

+34 670 636 004 · +34 617 294 803

Calle Colón, 1st Floor, local 213, Puerto Colón, 38660 Adeje

tenerifebusinessforsale.com · tenerife-property.com

English, Spanish, Dutch, Flemish, German, French, Danish

visit us here

bathrooms, one of the en suite. Large (50 m2) lounge/kitchen area. Outside you have a private garden and pool area. There is parking and storeroom. Air conditioning. Great family home in the residentila are but very close to all services and shops and only a short drive from ... For full information see website or contact:

Ref: V418-BP | Tenerife Belfin Properties | 692 146808

Granadilla,

€495,000

7 bed · Granadilla de Abona: Historic Guesthouse with Sunny Terrace, Seaview & Building Plot This historic townhouse with

Medical Facilities, Restaurants/ Bars/Cafes, Schools, Town, Transport, Shops ♦ Views: Garden, Sea ♦ Rooms: Hall/ Entrance, Store rooms, Independent Kitchen, Lounge and dining area, Fitted wardrobes, Ensuite, Bathroom, Family Bathroom, W. C. ♦ Quality: Quality... For full information see website or contact:

Ref: 5V3116 | Property Alliance SL | 922 777 747

San Eugenio Alto, Falcon Manor

€475,000

Luxury 2 bedroom, 2 bathroom apartment with garage.

Studio 4 Decor

NEW STORE NOW OPEN!

ACROSS THE ROAD FROM OUR OLD ONE IN LOS ABRIGOS

SEE OUR MAIN ADVERT ON PAGE 34

volcano-stonewalls aged for more than 300 years is now for sale in Tenerife South in Granadilla de Abona. Preceding its opening about 14 years ago, the owners have restored all the building's details with love and care and transformed the place... For full information see website or contact:

Ref: 20140599 | A1 Real Estate & Property Consultants | 922 729395

Charco del Pino, Finca

€495,000

5 bed · Three independent dwellings currently run as a rural B&B. Huge potential for further developments. Sun terrace, parking and panoramic views.

Ref: 1905 | Homes & Away | 922 737 044

San Eugenio Alto,

€490,000

3 bed · 3-storey detached house in the upper part of Las Americas (San Eugenio Alto). Upper floor: main apartment with 2 beds, 2 baths and terraces. Groundfloor: 1- bed guest apartment. Basement: large garage/workshop, office and toilet. All bedrooms with aircon. Resort with community pool. This nice property is completely renovated and will be sold part furnishe... For full

Tenerife Properties Ref: T1180 Tel: 699 250 870 / 608 573 443

Currencies Direct

Call Donna in our Los Cristianos office
+34-922 971 781 or Carol on +34-687 906 607

Palm Mar,

€475,000

2 bed · This spacious 2-bedroom apartment on the first floor in the exclusive and luxurious complex Bahia de los Menceyes offers guaranteed amazing ocean views and also panoramic views over the Nature Reserve La Rasca. It is in perfect condition and furnished with quality furniture and also has a fully equipped Italian kitchen with first class appliances. Both be... For full information see website or contact:

Ref: S 1009 | FRINA Tenerife SL - Property Sales | 922 085 191

Los Cristianos,

€473,000

2 bed · Tenerife-South: Duplex-Penthouse in Top-Location of Los Cristianos with Grandiose Roof-Deck and Breathtaking Views ---168 sqm of living space, thereof 60 sqm of roof-deck, main terrace 18 sqm, spacious kitchen, 2 BR, 2 bathrooms, garage and trastero, 2 pools (one heated during wintertime, fully furnished, air condition.

Ref: 20150598 | A1 Real Estate & Property Consultants | 922 729395

Parque de la Reina,

€472,000

5 bed · Belfin Property is proud to present for sale this lovely family home with an adjacent building plot. The house is built on 2 floors plus a roof terrace with utility room. Downstairs you have a large separate kitchen with a storage room. There is a guest bedroom and a bathroom with a sauna and also a guest toilet. The lounge is large (27 m2) and bright ... For full information see website or contact:

Ref: V401-BP | Tenerife Belfin Properties | 692 146808

Chayofa, Villa

€469,950

3 bed · Chayofa Country Club offers a number of private villas. They all have views of the southern Tenerife mountains and the sea beyond. The accommodation provides all the luxuries and benefits you would expect from a private villa, but with the added bonus of all the facilities of an apartment complex. All the villas have three en-suite bedrooms; they are very... For full information see website or contact:

Ref: LUX0492 | Tenerife Island Rentals and Buy Tenerife | 922 751072

San Eugenio, Las Flores

€465,000

2 bedroom, 2 bathroom bungalow in central location.

Tenerife Properties Ref: T1173 Tel: 699 250 870 / 608 573 443

Playa Fanabe, Townhouse

€450,000

4 bed · A great opportunity to purchase a large townhouse in a desirable area. Oasis de Fanabe is a residential complex of houses in the El Madronal de Fanabe area. This spacious

views. The villa measures 127m2 and the total plot area is 305m2. Also it has its own private swimming pool. The property has a... For full information see website or contact:

Ref: ROA3108 | 2nd Home Tenerife | 922 715 591

San Eugenio Alto,

€450,000

3 bed · This house has a new separate kitchen 2 big bedrooms with build in closets, big living room and a bathroom with bathtub. In the basement next to the spacious garage is a good size studio apartment complete with kitchen and bathroom. From the living room and master bedroom you have direct access to the terrace where you get a private pool and amazing sea v... For full information see website or contact:

Ref: 725 | FRINA Tenerife SL - Property Sales | 922 085 191

Los Menores,

€449,000

4 bed · Adeje: Fancy Villa with 4 Bedrooms, Separate Apartment and Pool in Scenic Location of Los Menores.

Ref: 20151199 | A1 Real Estate & Property

Tel: 638 918 684

- ✓ Therapeutic Massage
- ✓ General Physiotherapy
- ✓ Cervical Pain
- ✓ Neurological Physiotherapy
- ✓ Bobath Method
- ✓ Peretti Method
- ✓ Kinesiotaping
- ✓ Neoromuscular Bandage
- ✓ Dry Needling
- ✓ Neurodynamic Techniques
- ✓ Functional Recovery
- ✓ Electrotherapy

Ma Milagros Sancho Martin, Col. No: 117 Carretera General Guaza, No 9, GUAZA

Monday - Friday
9am - 1pm, 3pm - 6pm

Consultants | 922 729395

Los Cristianos, Townhouse

€449,000

2 bed · A luxurious semi detached town house for sale on the Golf Course in Los Cristianos. Located on an exclusive complex consisting of only 52 properties between private villas and town houses, this spectacular dwelling is furnished to very high standards with high-end furnishings and a bespoke kitchen. The property is split with a south facing living room, se... For full information see website or contact:

Ref: LC024-GR449 | RD Properties | 922 732 862

Guargacho, Villa

€434,900

4 bed · DETACHED VILLA! RD Properties are pleased to present this wonderful family home only ten minutes away from Las Galletas. A detached villa built on two levels. Ground floor consisting of a large living room, separate kitchen fully equipped and a toilet. Big front garden and garage accessible from the living room. A huge back garden which can be used as your... For full information see website or contact:

Ref: GU314-434 | RD Properties | 922 732 862

El Duque,

€430,000

1 bed · Splendid one bedroom apartment in the brand new 5 star complex in the El Duque area. In this apartment you will find state of the art materials and a very practical layout with an equipped kitchen with island, a bathroom with double sink, shower and bath, an open living room and a very spacious and sunny terras. This apartment is very light and bright and... For full information see website or contact:

Ref: RD1081 | 2nd Home Tenerife | 922 715 591

Palm Mar,

€425,000

3 bed · Three bed, three bath private detached villa in a secured and quiet location close to the sea. Garden with swimming pool and jacuzzi. The large roof terrace has mountains and sea views.

Ref: 1776 | Homes & Away | 922 737 044

El Galeon,

€420,000

4 bed · Lovely 4 bedroom, 3 bathroom (1 en suite) villa being sold fully furnished. There is a large lounge, separate luxury fitted kitchen, laundry room plus extra storage room and terraces all around the property. Off the main bedroom there is a large balcony with amazing coastal views. Also includes a garage for 5 cars and community swimming pool. This is a lo... For full information see website or contact:

Ref: S-04 1337 | Tenerife Prime Property | 922 703 725

Arona,

€420,000

3 bed · Nicely decorated villa

located close to Los Cristianos, quiet area, consists of 3 bedrooms, 3 bathrooms, fully equipped kitchen, dining area, lounge with home cinema, private terrace created as a relax zone with heated jacuzzi. Each bedroom has its private bathroom. Garage with a space for 2 cars, laundry room. There are 3 swimming pools in the complex, o... For full information see website or contact:

Ref: ROA3128 | 2nd Home Tenerife | 922 715 591

Playa Fanabe, Townhouse

€420,000

4 bed · Beautiful four bedroom property located on the La Capitana complex in El Galeon. On the ground floor there is a large living room, kitchen, bedroom and bathroom and on the upper floor there are three good sized bedrooms and two bathrooms, the master bedroom is ensuite. Although located on a complex with community pool, this property feels like a detached ... For full information see website or contact:

Ref: PUE0402 | Tenerife Island Rentals and Buy Tenerife | Sales: 922 751072 / Rentals: 922 797438

Roque del Conde, Townhouse

€399,950

4 bed · Lovely, spacious, fully furnished and equipped 4 bed, 4 bath (2 en suite) semi-detached townhouse with own swimming pool in quiet, sought after complex situated close to amenities. The property, which enjoys lovely sea and La Gomera views, has a lounge/ diner, independent fully fitted kitchen, terrace/garden, and double garage. A very nice family home.

Ref: S-04 1395 | Tenerife Prime Property | 922 703 725



WE HAVE MOVED

C.C. Rio Center, local 6A
TORVISCAS BAJO (near the old Sky Park)
 ☎ 922 713 116
 📞 692 146 808 / 670 801 154
 Web: www.tenerife-belfin-property.com
 Email: info@tenerife-belfin-property.com

Find us:



SAN EUGENIO BAJO, TENERIFE GARDEN



<p>1 BED, 1 BATH BUNGALOW</p> <p>Fully furnished, 1 bed, 1 bath bungalow with large sunny terrace excellent location near shops and restaurants and only a short walk from the Puerto Colon beach and marina.</p> <p>€175,000 Ref: BU012-HP</p>	<p>2 BED, 2 BATH BUNGALOW</p> <p>Spacious (80sqm + 50sqm sunny terrace), 2 bed, 2 bath bungalow on this popular complex close to shops, beach and Puerto Colon marina.</p> <p>€360,000 Ref: BU202-HP</p>
------------------------------------------------------------------------------------------------------------------------------------------------------------------------------------------------------------------------------------------------------------------	---------------------------------------------------------------------------------------------------------------------------------------------------------------------------------------------------------------------------

SAN EUGENIO ALTO, FANTASTIC BUNGALOW!



Fantastic, spacious (65sqm built plus 75sqm terrace on plot of 144sqm) 2 bed, 1 bath bungalow in sought after location. The property has a large lounge/dining area with open plan kitchen, good-sized storeroom and a lovely sunny terrace with views over Las Americas to the sea. Great location, only a few minutes' walk from the busier tourist areas. A great opportunity for a good price and NO community fees!

€189,000 **BU204-BP**

LAS AMERICAS, OLYMPIA



Excellent, refurbished, and fully furnished studio in popular complex with pool, close to the beach and all amenities. The property, in a great location, has a lovely sunny balcony with sea views.

€145,000 ST112-HP

TORVISCAS BAJO, PARQUE ROYALE



Lovely, fully refurbished and furnished studio apartment in popular complex with pool and lifts and just a short stroll from the beach and amenities. The property has a nice sunny terrace. Great rental potential.

€149,000 ST105-HP

SAN EUGENIO ALTO, HOLIDAY VALLEY



Lovely, fully furnished 2 bed, 1 bath, bungalow on large corner plot in a nice complex with pool. The property has a spacious, bright lounge/diner, open plan fitted kitchen, a private sunny terrace with sea views and a garden with space for a pool.

€295,000 BU203-BP

LAS AMERICAS, PARQUE LAS AMERICAS



Lovely, fully furnished, 1 bed, 1 bath apartment in nice complex with heated pool, pool bar, gym and Reception just 3 minutes' walk to the beach! The property has a 2nd bedroom/storeroom, an open plan lounge/diner and kitchen, and a fabulous sunny terrace with sea views! Close to all amenities.

€210,000 AP130-BP

MIRAVERDE, LAS ESTRELLAS



Refurbished and fully furnished, 2 bed, 2 bath (1 en suite) apartment in popular complex in Fanabe village. The property has a spacious open plan kitchen and lounge with access to a sunny terrace. Community Fees include the use of the Miraverde swimming pool!

€190,000 AP204-HP

GOLF DEL SUR, GREEN PARK



Lovely, refurbished and fully furnished 1 bed, 1 bath apartment (tastefully converted from a studio). Great as a holiday apartment or rental property. The complex has a nice pool area and has many services nearby.

€99,000 ST111-AG

ROQUE DEL CONDE



Lovely, spacious, 2 bed, 2 bath (1 en suite) townhouse in lovely residential complex with pool. The property has 2 good-size terraces with sea views and a private, closed garage.

€265,000 TH205-HP

GUIA DE ISORA, CHIGUERGUE



Finca with 1,000sqm of fenced-in land plus a 3 bedroom house with great outside space, vegetable garden and greenhouse. Fantastic views to the coast.

€158,000 F108-BP

AMARILLA GOLF, PINEHURST



Spacious 1 bedroom apartment with closed in terrace. Views to the golf course and the sea. Complex with a communal pool and pool bar. Lift.

€132,000 AP108-BP

LAS AMERICAS, NEAR SEA FRONT



Fantastic, refurbished and furnished, 2 bed 2 bath ground floor apt near the sea front. Small complex (5 apartments). NO Community Fees! Extras incl. satellite TV, aircon, solar panels. Excellent rental potential!

€350,000 AP207-HP

San Eugenio Alto,
€399,000
3 bed · Beautiful detached villa in San Eugenio with spectacular sea views. The property has 3 bedrooms with fitted wardrobes and 2 complete bathrooms, one with bath and the second one with shower. Also there is a fully fitted kitchen, a utility room, a guest toilet and a large living room with lots of natural light and splendid views over Costa Adeje. The villa ... For full information see website or contact:
Ref: ROA3069 | 2nd Home Tenerife | 922 715 591

Amarilla Golf,
€390,000
4 bed · For sale 9 attractive detached villas in Green South Villas, Amarilla Golf. It has an emblematic design. To build these properties, natural materials have been used that are in harmony with the surrounding landscape. The design of the villas and how they fit into their location creates an atmosphere of tranquility that will allow you to enjoy their terrac... For full information see website or contact:
Ref: ROA4135 | 2nd Home Tenerife | 922 715 591

Amarilla Golf,
€390,000
4 bed · Belfin Property is proud to present this new luxury development located on the south coast of Tenerife at the Amarilla Golf urbanization. Just 9 brand new detached villas are available for discerning buyers, at exceptional prices. Green South Villas enjoy spectacular views of the golf course and the mountains. Each villa has four bedrooms, three bathrooms... For full information see website or contact:
Ref: V428-BP | Tenerife Belfin Properties | 692 146808

Arona,
€375,000
4 bed · This surprisingly spacious apartment in Los Cristianos is very comfortable and situated just a few steps away from the "playa de las Vistas" beach, many shops and restaurants. Its layout also offers many possibilities. In the apartment there are 4 bedrooms, 2 bathrooms, 2 kitchens, a laundry room, a large living room with dining area, a 15 m2 terrace on t... For full information see website or contact:
Ref: ROA4078 | 2nd Home Tenerife | 922 715 591

Torviscas Alto,
€375,000
2 bed · With the opening of CC Gran Sur, Torviscas Alto has now become one of the most attractive areas, just outside Las Americas. Resid. complex with lovely pool area* Bung. with 2 bedrooms and 2 bathrooms (1 ensuite)*Sun all day *Unique views of Las Americas, Atl. and La Gomera. This beautiful property will be sold furnished with garage space and store room.
Ref: 85-306 | Dr Stange International | 922 793271

Roque del Conde,
€365,000
4 bed · Magnificent house on corner plot. 4 bedrooms, 3 bathrooms. Lounge, dining area, independent kitchen, garage for 3 cars. Large terrace and private garden. All with excellent views. Complex with pool.
Ref: Corner | MK Properties | 922 751 / 630

994991
Acojeja,
€357,000
5 bed · We offer for sale this completely renovated and spacious 740m2 house in Acojeja, Guia de Isora. The living space is 278m2 divided into three floors which comprise five bedrooms, three bathrooms, two kitchens, two lounges and four terraces of 200m2 from where you have almost 360 degrees of sea and mountain view. There are three separate entrances to the ho... For full information see website or contact:
Ref: D 1077 | FRINA Tenerife SL - Property Sales | 922 085

MBS Physiotherapy Tel: 638 918 684

<ul style="list-style-type: none"> ✓ Therapeutic Massage ✓ General Physiotherapy ✓ Cervical Pain ✓ Neurological Physiotherapy ✓ Bobath Method ✓ Perletti Method 	<ul style="list-style-type: none"> ✓ Kinesiotaping ✓ Neoromuscular Bandage ✓ Dry Needling ✓ Neurodynamic Techniques ✓ Functional Recovery ✓ Electrotherapy
-----------------------------------------------------------------------------------------------------------------------------------------------------------------------------------------------------------------------------	------------------------------------------------------------------------------------------------------------------------------------------------------------------------------------------------------------------------

Ma Milagros Sancho Martin, Col. No: 117 Carretera General Guaza, No 9, GUAZA Monday - Friday 9am - 1pm, 3pm - 6pm

191
San Eugenio Alto,
€350,000
3 bed · Large, semi-detached house set in a quiet cul-de-sac of only 9 houses. This property has 3 bedrooms, 1 bathroom & 2 x w. c's, large lounge/dining room and a galley kitchen. The house has numerous terraces on different levels with fabulous sea views. There is a 56m2 garage underneath the house and 2 caves, each 16m2 which are used as a gym and a wine cella... For full information see website or contact:
Ref: S-03 1283 | Tenerife Prime Property | 922 703 725

Costa del Silencio,
€350,000
3 bed · For sale that three-story, fully furnished townhouse located in Costa del Silencio in the urbanization Los Azahares. The house has an interior area of 160m2 distributed as follows: Main floor: independent and equipped kitchen, living room, a toilet, a 20 m2 glazed terrace. Upper floor: distributed in two spacious rooms, a bathroom and two balconies of 6 m2... For full information see website or contact:
Ref: S 1120 | FRINA Tenerife SL - Property Sales | 922 085 191

Palm Mar,
€350,000
2 bed · Location- Quiet location- Close to shops- Residential area- Close to the coast- Close to transport- Central- Exclusive development- Close to amenities- Gated community- Close to restaurants/bars/cafes Views- La gomera- Pool- Sea Additional- Viewing recommended Rooms- Bathroom- Fitted wardrobes- Lounge and dining area- W. c. Quality- Built to a high standard... For full information see website or contact:
Ref: 504-D2 | Island Estates | 922 790 767

Alcala, Finca
€350,000
1 bed · Location: Quiet location, Rural location. Views: Mountain, Sea, La gomera. Additional: Development possibilities, Viewing recommended. Rooms: Bathroom, Lounge and dining area, American style kitchen.

Quality: Rustic style. Outside: Various gardens, Various terraces, Garden, Sunny terrace. Parking: Off street parking.
Ref: 406-F1 | Island Estates | 922 790 767
€349,999 - €250,000

El Duque,
€349,000
1 bed · Luxury, fully furnished and equipped 1 bedroom, 1 bathroom apartment in lovely sea front complex with 3 pools. The property (48sqm + 7sqm terrace/balcony) has a lounge/diner, an American-style kitchen, and is fully air conditioned.

Ref: PMSR0017 | Palm Mar Sales and Rentals | 677-623713 / 671-129558

Costa del Silencio,
€340,000
6 bed · Large house in popular area of Costa del Silencio which is on 3 floors. There are 6 bedrooms, 3 bathrooms, separate fitted kitchen, lounge, various terraces, patios and large car port. This property needs some tlc but has lots of potential to be a fabulous family home.
Ref: S-06 1314 | Tenerife Prime Property | 922 703 725

Los Abridgos,
€339,000
3 bed · Luxury 3 bedroom corner townhouse for sale in a small seafont complex. Lovely tranquil location by one of the best beaches of Tenerife. The house is sold fully furnished with many extras, including a Jacuzzi and a mini-gym. Sea views from both floors. Great family home!
Ref: TH305-AG | Tenerife Belfin Properties | 692 146808

Palm Mar,
€330,000
2 bed · Beautiful, bright and spacious two bedroom, two bathroom apartment on the modern Las Olas complex which stands at the entrance to Palm Mar. A short walk takes you to the sea front and all of the amenities that this up and coming village has to offer. There are two terraces, one that overlooks the swimming pool. The property is sold fully furnished and the ... For full information see website or contact:
Ref: PMSR0051 | Palm Mar Sales and Rentals | 677-623713 / 671-129558

El Madronal, Townhouse
€330,000
3 bed · Beautiful three bedroom two bathroom townhouse property in very popular complex in El Madroñal. On the lower level there is a fully fitted kitchen and utility area, WC and large living room with direct access to the front terrace. There is also a private rear terrace to the property offering ample outdoor living space. On the upper floor there is a large ... For full information see website or contact:
Ref: ADO0438 | Tenerife

Island Rentals and Buy Tenerife | Sales: 922 751072
Guargacho, Detached House
€329,000

4 bed · Gorgeous family home situated in Granadilla de Abona, boasting stunning open air spaces with mountain and seaviews. The two-story property is built on 140m2, of an overall area of approximately 205m2. The residence consists of four double bedrooms, two of which have en-suite bathrooms, plus two separate bathrooms. There is an open air private garage for t... For full information see website or contact:
Ref: GDA413-CA329 | RD Properties | 922 732 862

Los Abridgos,
€326,000
3 bed · If you are looking for a new home in Tenerife then this new refurbished detached house is a great option. You get a new home only 40 meters from the beach, with a large garden with sea and mountain view, styled to a high standard, placed in a newer complex that is quiet and with community pool. The house is 102 m2 with 2 floors and decorated to high stand... For full information see website or contact:
Ref: 745 | FRINA Tenerife SL - Property Sales | 922 085 191

Las Americas,
€321,000
1 bed · Parque Santiago III has been built in 1987/1988 and is situated in front of a beach. It is one of the most prestigious holiday apt. complexes in the south of Tenerife. Unique pool (2000 m2!), sunbathing area, immaculate garden flora/fauna and rest./pool bar on site. Apt. on the ground floor (one level) *Sun in the morning, large terrace and garden *Excl. ... For full information see website or contact:
Ref: 82-739 | Dr Stange International | 922 793271

Adeje Town,
€320,000
4 bed · This beautiful house combines the newest materials with the spirit of a traditional townhouse. It is a traditional Canarian house with all its charms that has been completely rebuilt with modern materials for the owners to enjoy all modern commodities. It is very light and bright and offers views to the ocean and the roofs of Adeje. It is close to the Call... For full information see website or contact:

Call Donna in our Los Cristianos office +34-922 971 781 or Carol on +34-687 906 607

Ref: ROA4066 | 2nd Home Tenerife | 922 715 591
Callao Salvaje, Apartment
€320,000

3 bed · Beautifully presented two bedroom apartment in popular complex in Callao Salvaje. This property has two good sized bedrooms and bathroom, large living room and very large terrace with pool views. There is also a large independent kitchen. The integrated garage has been converted into additional living space with a bedroom, living

area and bathroom however... For full information see website or contact:
Ref: AP0535 | Tenerife Island Rentals and Buy Tenerife | Sales: 922 751072

Callao Salvaje,
€315,000
3 bed · Location close to restaurants/bars/cafes, close to shops Views pool, sea, garden Additional viewing recommended Rooms ... For full information see website or contact:
Ref: 442-TH3 | Island Estates | 922 790 767

Palm Mar,
€299,000
2 bed · ♦ Location: Residential Area, Popular urbanisation, Gated community, Close to the coast, Close to the beach, Close to amenities ♦ Close to: Transport, Medical Facilities, Coast, Restaurants/Bars/Cafes ♦ Rooms: Store rooms, Fitted wardrobes, Lounge and dining area, Open plan kitchen ♦ Quality: Quality residence, Bright, Tastefully decorated, Well presented... For full information see website or contact:
Ref: 2A3368 | Property Alliance SL | 922 777 747

Callao Salvaje,
€295,000
3 bed · ♦ Location: Touristic Area, Popular urbanisation, Close to the beach ♦ Close to: Shops, Transport, Town, Beach, Restaurants/Bars/Cafes ♦ Views: Sea ♦ Rooms: Fitted wardrobes, Open plan kitchen ♦ Quality: Spacious, Unfurnished ♦ Outside: Alfresco Dining area, Pagoda, Large Terrace, Sunny Terrace ♦ Parking: Street parking ♦
Ref: 3A3259 | Property Alliance SL | 922 777 747

Amarilla Golf,
€295,000
3 bed · Modern three bed, two 1/2 bath terraced villa built on high standards with back patio,

terrace overlooking the pool and large double garage.
Ref: 2023 | Homes & Away | 922 737 044

San Eugenio Bajo,
€295,000
2 bed · Tenerife-South: San Eugenio Bajo, Chic 2-Bedroom Apartment, Seafont Location in Club Villamar, Beautiful Pools and Gardens. All inquiries welcome!
Ref: 20141298 | A1 Real Estate & Property Consultants | 922 729395
Los Cristianos,

€290,000
2 bed · Location- Close to schools- Close to shops- Central- Close to the beach- Close to amenities- Touristic area- Close to medical facilities- Close to restaurants/bars/cafes Views- Sea Additional- Viewing recommended Rooms- American style kitchen Quality- Well presented Outside- Sunny terrace Community facilities- Bar- Heated swimming pool Parking- Street parking.
Ref: 528-A2 | Island Estates | 922 790 767

Los Cristianos,
€250,000
2 bed · Duplex apartment, being sold part furnished with 2 bedrooms, 2 bathrooms, lounge and American style kitchen. There is a small front garden and a large terrace off the lounge overlooking the community swimming pool. There is also a balcony off the upstairs bedroom. This property needs to have some refurbishing done, it is in a complex with easy off road pa... For full information see website or contact:
Ref: S-02 1150 | Tenerife Prime Property | 922 703 725

San Eugenio Bajo,
€250,000
2 bed · Spacious (76sqm +

Studio 4 Decor

NEW STORE NOW OPEN!

ACROSS THE ROAD FROM OUR OLD ONE IN LOS ABRIGOS

SEE OUR MAIN ADVERT ON PAGE 34

35sqm terrace), fully furnished 2 bedroom, 1 bathroom duplex apartment in popular complex with pool and close to beach, harbour and all amenities.
Ref: PMSR0032 | Palm Mar Sales and Rentals | 677-623713 / 671-129558

€249,999 - €150,000

Golf del Sur, Bungalow
€249,950
2 bed · Spacious, fully furnished 2 bed, 2 bath (1 en suite) house on popular holiday complex with heated pool and restaurant and located close to all amenities. The property has a lounge-diner, independent fitted kitchen, front garden, large rear garden and terrace and a private, sunny rooftop terrace with excellent views.
Ref: S-02 1396 | Tenerife Prime Property | 922 703 725

El Madronal,
€249,900
3 bed · Spacious (187sqm + 40sqm terrace), fully furnished, 3 bedroom, 3 bathroom duplex in complex with pool. Close to all amenities (Gran Sur, Siam Park, Water Park etc).
Ref: PMSR0025 | Palm Mar Sales and Rentals | 677-623713 / 671-129558

Los Cristianos,
€240,000
2 bed · Beautiful, fully furnished and equipped, 2 bedroom, 1 bathroom apartment in small residential complex just metres from the beach in central Los Cristianos - the perfect location with great investment potential! This spacious (50sqm) property has a lounge/dining room, American-style kitchen, and 12sqm terrace overlooking the



Tenerife Properties.ES

info@tenerifeproperties.es www.tenerifeproperties.es

JOY +34 620 253 957

PABLO +34 620 731 368

CATERINA +34 649 851 608

Villa, Roque del Conde



Large 3 storey villa with stunning views and a lift inside!

Price: €1,900,000 Ref: 7900



Abama, Terrazas de Abama



Stunning two bedroom, two bathroom, ground floor property with sea views in the prestigious resort of the Terrazas de Abama.

Price: €750,000 Ref: 15136

Santa Maria, Torviscas Bajo



First Floor studio in the established apart/hotel of Santa Maria. Overlooking the pool. Sold fully furnished. Established rental calendar.

Price: €165,000 Ref: 17242

Santa Maria, Torviscas Playa



Third floor 1 bedroom apartment (lift access) with double balcony and stunning sea views. Reduced for a quick sale.

Price: €199,000 Ref: 11248

Lagos de Fañabe, Playa Fañabe



Top floor one bedroom, air conditioned apartment on front line holiday complex close to bars, restaurants, shops and walking distance to the beach.

Price: €249,000 Ref: 7826

Amarilla Golf, Sun Bay Villas



Lovely, light airy duplex on a plot of 59 duplexes situated on the new development of Sun Bay Villas located on Amarilla Golf

Price: €295,000 Ref: 13333

Las Carabelas, Torviscas Bajo



Las Carabelas is the hidden gem of Torviscas. 2 bed (both double), 2 bath duplex apartment (1 with bath, the other with walk-in shower).

Price: €350,000 Ref: 7595

Terrazas del Duque II, Bahía del Duque



Lovely 1 bed, 1 bath apartment in prestigious resort.

Price: €299,000 Ref: 15367

Villas Fañabe, Costa Adeje Duque II



Immaculate 2 bed, 1 bath apartment, for sale fully furnished in this prestigious resort, included with a calendar of reservations.

Price: €435,000 Ref: 14856

El Duque, Villas del Duque



Beautiful 4 bedroom, 3 bathroom townhouse in this prestigious residential complex. Recently refurbished with high quality materials, with airconditioning throughout.

Price: €610,000 Ref: 13965

Avda. Ernesto Sarti s/n, Pueblo Torviscas, local M2, COSTA ADEJE 38670

piazza. Underground car parking... For full information see website or contact:
Ref: S-02 1144 | Tenerife Prime Property | 922 703 725

Los Cristianos,

€240,000

2 bed · Centrally located only 30 metres from the beach, Playa de las Vistas. This two bedroom apartment is sold fully furnished and the price includes a garage for two cars and private storeroom.
Ref: PMSR0018 | Palm Mar Sales and Rentals | 677-623713 / 671-129558

Los Cristianos, Apartment

€240,000

1 bed · Presenting a bright and spacious ground floor apartment situated in a well-maintained residential complex located in Los Cristianos. The total plot boasts a fantastic 233sqm, in which you will find an apartment consisting of a kitchen, a living/dining area, a double bedroom and a bathroom. The family room allows access straight to the private, sunny terra... For full information see website or contact:

Ref: LC822-PT240 | RD Properties | 922 732 862

Palm Mar,

€235,000

2 bed · Spacious, two bedroom, two bathroom apartment on the well maintained complex of Los Balandros in the lovely coastal village of Palm Mar. Situated within a short stroll to all of the amenities the area has to offer. The property is sold fully furnished and the price includes a storeroom and private, underground parking space. The complex has attractive ... For full information see website or contact:

Ref: PMSR0070 | Palm Mar Sales and Rentals | 677-623713 / 671-129558

Callao Salvaje,

€235,000

3 bed · Spacious home on 3 floors with 3 bedrooms, large living room, kitchen, parking, nicely furnished. Heated, solar panel and many extras. The complex has a Jacuzzi, large swimming pools and gym.
Ref: Sonia, Callao | MK Properties | 922 751 / 630 994991

Chayofa, Duplex

€230,000

2 bed · Location: Exclusive development, Popular urbanisation, Central, Quiet location, Close to amenities, Touristic area, Close to restaurants/bars/cafes, Close to transport. Views: Pool. Additional: Viewing recommended. Rooms: American style kitchen, Bathroom, Ensuite, Fitted wardrobes, Lounge and dining area. Quality: Built to a high standard, Furnished, Good... For full information see website or contact:

Ref: 543-A2 | Island Estates | 922 790 767

Parque de la Reina, Duplex

€230,000

4 bed · Magnificent duplex for sale in Parque de la Reina, Arona which boasts an excellent layout. On the top floor there are 3 bedrooms, one with an en suite bathroom and terrace, 2 small bedrooms and 1 bathroom. On the ground floor you will find a terrace in which you enter the house a, large living-room, an independent kitchen with pantry and a toilet. In the ... For full information see website or

contact:

Ref: PDLR912-CB230 | RD Properties | 922 732 862

San Eugenio Alto, Townhouse

€230,000

2 bed · ♦ Location: Residential Area, Popular urbanisation ♦ Views: Sea ♦ Rooms: Hall/ Entrance, Open plan kitchen, Fitted wardrobes, Lounge and dining area ♦ Quality: Furnished, Immaculate condition, Well presented ♦ Features: Satellite system, Security shutters ♦ Outside: Sunny Terrace ♦ Parking: Private garage ♦
Ref: 2TH3414 | Property Alliance SL | 922 777 747

Palm Mar,

€229,000

2 bed · ♦ Location: Residential Area, Popular urbanisation, Gated community, Close to amenities ♦ Close to: Transport, Restaurants/Bars/Cafes ♦ Views: Garden ♦ Rooms: Store rooms, Fitted wardrobes, Independent Kitchen ♦ Quality: Spacious, Well presented, Immaculate condition, Furnished ♦ Features: Sun



NEW STORE NOW OPEN!

ACROSS THE ROAD FROM OUR OLD ONE
IN LOS ABRIGOS

SEE OUR MAIN ADVERT ON PAGE 34

blinds, Jacuzzi ♦ Outside: Alfresco Dining area, Large Terrace... For full information see website or contact:

Ref: 2A3315 | Property Alliance SL | 922 777 747

Llano del Camello,

€225,000

4 bed · Location quiet location, close to amenities, residential area, close to restaurants/bars/cafes, close to town, close to transport, central, gated community, close to airport Views mountain, pool, sea Additional ... For full information see website or contact:
Ref: 335-TH4 | Island Estates | 922 790 767

Golf del Sur,

€222,500

2 bed · Large, fully furnished, corner villa with 2 bedrooms, 2 bathrooms (1 ensuite), large lounge, separate kitchen and wraparound gardens and terraces. There is a huge roof terrace with a storeroom and lovely views to the sea, Teide and the golf course. The property is fully air conditioned and has a community swimming pool.
Ref: S-02 1342 | Tenerife Prime Property | 922 703 725

Callao Salvaje, Duplex

€220,000

2 bed · ♦ Location: Touristic Area, Popular urbanisation, First line to the Beach, Close to amenities ♦ Close to: Transport, Restaurants/Bars/Cafes, Beach ♦ Views: Teide, Sea ♦ Rooms: Utility room, W. C., Fitted wardrobes, Independent Kitchen ♦ Quality: Well presented, Charming property, Furnished ♦ Outside: Sunny Terrace, Large Roof Terrace ♦ Parking: Private pa... For full information see website or contact:
Ref: 2D3451 | Property Alliance SL | 922 777 747

Los Cristianos, Apartment

€220,000

1 bed · Beautifully renovated ground floor apartment in Victoria Court I. This apartment has been renovated to a very high standard and being on the ground floor has direct access to the pool area from the terrace. The property consists of a large double bedroom, shower room, large living room with American style kitchen and large terrace of 14m2. The complex has... For full information see website or contact:

Ref: AP0434 | Tenerife Island Rentals and Buy Tenerife | Sales: 922 751072

Llano del Camello, Townhouse

€215,000

3 bed · This townhouse has an independent entrance with a terrace and a private garage which allows direct access to the property. On the ground floor there is a living room, a guest bathroom and a bright American kitchen. The first floor consists of two large bedrooms and a full bathroom complete

village of Palm Mar ... For full information see website or contact:

Ref: PMSR0071 | Palm Mar Sales and Rentals | 677-623713 / 671-129558

Playa Fanabe,

€199,000

1 bed · Spacious apartment (65m2) in the prestigious complex. With 1 bedroom, 1 bathroom, and spacious terrace. Fully renovated and luxuriously furnished. Pool on complex.
Ref: Villas de Fanabe | MK Properties | 922 751 / 630 994991

Palm Mar, Apartment

€195,000

2 bed · Lovely two bed property for sale in Palm-mar, the apartment is being sold fully furnished, ready to move in. Located on the Primavera complex, the property is on the second floor with a community lift and pool. The complex is very well maintained with a lot of garden area surrounding the pool. Gated enclosure with security. Palm-mar is an exclusive area w... For full information see website or contact:

Ref: PM091-RP195 | RD Properties | 922 732 862

Guia de Isora, Canarian House

€195,000

2 bed · ♦ Location: Quiet location, Rural Location ♦ Views: Garden, Mountain, Sea, La Gomera ♦ Rooms: American Style Kitchen, Lounge and dining area, Bathroom ♦ Features: Fruit Trees, Tropical garden ♦ Outside: Mature Garden ♦

Ref: 2CH3209 | Property Alliance SL | 922 777 747

Costa Adeje,

€190,000

1 bed · Beautiful studio in the popular tourist area of Costa Adeje in the complex Mareverde, just 10 minutes walk from Fanabe beach. The apartment is sold with furniture, consists of 1 bedroom, 1 bathroom and a living room with open plan kitchen and access to the terrace with views of the ocean and mountains. In the complex there are different swimming pools. Co... For full information see website or contact:

Ref: S 1005 | FRINA Tenerife SL - Property Sales | 922 085 191

Llano del Camello,

€189,000

3 bed · 3 storey house being sold partly furnished with 3 bedrooms, 2 bathrooms (1 en suite) + w. c. There is a good size lounge and a separate fitted kitchen. There is a terrace off the top floor bedroom and one off the lounge. There is also an underground garage space and private storeroom. The owners of this property would be interested in doing a Rent with an... For full information see website or contact:
Ref: S-03 1215 | Tenerife Prime Property | 922 703 725

Palm Mar, Apartment

€199,950

1 bed · Bright and spacious duplex apartment with very large solarium benefiting from all day sunshine. Overlooking the 49 metre swimming pool, one of two on the complex, there are also views out to sea and the Island of La Gomera. The property is situated on the lovely complex of Los Balandros close to all of the amenities that the coastal

Prime Property | 922 703 725

Los Abrigos, Apartment

€189,000

1 bed · ♦ Location: Central, Close to amenities, Close to the beach, Close to the coast, Touristic Area ♦ Close to: Beach, Coast, Medical Facilities, Restaurants/Bars/Cafes, Schools, Shops, Town, Transport ♦ Views: Sea, Mountain ♦ Rooms: Hall/ Entrance, Bathroom, American Style Kitchen ♦ Quality: Furnished, Renovated ♦ Outside: Sunny Terrace ♦ Parking: Parking ava... For full information see website or contact:

Ref: 1A3300 | Property Alliance SL | 922 777 747

Palm Mar, Apartment

€187,000

1 bed · Fully furnished 1 bed, 1 bath apartment in good condition on community with pool. The property enjoys sea views and views over the nature reserve. Community fee: +- 42 euros per month. IBI: +- 131 euros per year.
Ref: PMSR0073LM | Palm Mar Sales and Rentals | 677-623713 / 671-129558

Callao Salvaje,

€185,000

2 bed · Semi-detached house on 3 floors with 2 bedrooms, 2 bathrooms, kitchen and large garage. The complex has heated swimming pools, childrens playground, and tennis court.

Ref: Mariben, Callao | MK Properties | 922 751 / 630 994991

San Eugenio Alto,

€183,000

1 bed · We have a one bedroom apartment for sale in Garden City, San Eugenio. This is formally a bank property and amongst other things it is in need of complete refurbishment. If you have a serious interest in this property then call the office.

Ref: S 1012 | FRINA Tenerife SL - Property Sales | 922 085 191

Los Cristianos, Duplex

€180,000

2 bed · Duplex apartment with two bedrooms and two bathrooms in Castle Harbour. Good sized living room with kitchen area and nice balcony from the living room area. This is an ideal investment property or for a holiday home. There is a 24 hour reception, laundry, pool bar and large community



MBS Physiotherapy

Tel: 638 918 684

- ✓ Therapeutic Massage
- ✓ General Physiotherapy
- ✓ Cervical Pain
- ✓ Neurological Physiotherapy
- ✓ Bobath Method
- ✓ Perfetti Method

- ✓ Kinesiotaping
- ✓ Neoromuscular Bandage
- ✓ Dry Needling
- ✓ Neurodynamic Techniques
- ✓ Functional Recovery
- ✓ Electrotherapy

Ma Milagros Sancho Martin, Col. No: 117
Carretera General Guaza, No 9, GUAZA

Monday - Friday
9am - 1pm, 3pm - 6pm

swimming pool. There is also an on site management company allowing holi... For full information see website or contact:

Ref: DUP0512 | Tenerife Island Rentals and Buy Tenerife | Sales: 922 751072

Palm Mar,

€179,995

1 bed · Delightful one bedroom apartment on the well run complex of Laderas del Palm Mar. With views of the lovely pool area the apartment is bright and spacious. The

complex is within a short stroll to the many amenities the charming coastal village of Palm Mar has to offer.
Ref: PMSR0067 | Palm Mar Sales and Rentals | 677-623713 / 671-129558

Las Americas,

€179,900

♦ Location: Central, Close to amenities, Gated community, Popular urbanisation, Touristic Area, Second line to the beach ♦ Close to: Beach, Harbour, Restaurants/Bars/Cafes, Medical Facilities ♦ Views: Sea, La Gomera ♦ Rooms: American Style Kitchen ♦ Quality: Furnished, Well presented ♦ Outside: Sunny Terrace ♦ Parking: Street parking ♦ C... For full information see website or contact:

Ref: OS3377 | Property Alliance SL | 922 777 747

Callao Salvaje,

€178,000

2 bed · A house on 3 floors with large garage, 2 bedrooms, and 2 terraces with views. In very quiet area. Complex has heated pool, playground, and tennis court.

Ref: Pareada, Callao Salvaje | MK Properties | 922 751 / 630 994991

Los Cristianos,

€176,000

1 bed · For sale is this modern just recently refurbished 1 bed apartment with sea views. The apartment is situated in the complex La Estrella, which offers a pool and is only a 2 minutes stroll away from the beach of Los Cristianos. Several bars and restaurants are practically at your doorstep. The property measures approximately 60 m2 and comprises of a bright ... For full information see website or contact:

Ref: 623 | FRINA Tenerife SL - Property Sales | 922 085 191

Costa del Silencio, Apartment

€176,000

2 bed · This fantastic ground floor property in Costa del Silencio consists of two bedrooms with fitted wardrobes, a lounge, an independent fully equipped kitchen, a bathroom complete with bath and a lovely terrace. To be sold fully furnished and with a garage space. Situated in a complex which features 2 community pools, a children's park and a small gym. You ca... For full information see website or contact:

Ref: CDS761-A176 | RD Properties | 922 732 862

San Eugenio Alto,

€169,000

1 bed · Location close to amenities, close to town, quiet location, residential area Views la gomera, sea Additional viewing recommended Rooms ... For full information see website or contact:
Ref: 221-A1 | Island Estates | 922 790 767

Aguilas del Teide,

€168,000

1 bed · Beautiful, fully furnished 1 bed, 1 bath apartment with American style fully fitted kitchen, good size lounge and a 40m2 garden and terrace with lovely sea views. There is also a garage space included in the price. Community swimming pool.
Ref: S-01 1359 | Tenerife Prime Property | 922 703 725

Aguilas del Teide, Apartment
 €165,000

1 bed · This stylish first floor apartment has been totally

TENERIFE PROPERTY SHOP S.L.

G.I.P.E. NO. 3722

Service



Security

! NEW !

5 BEDROOM FINCA - CRUZ DE TEA, GRANADILLA



RURAL OPPORTUNITY



This beautiful Finca is nestled close to the picturesque pueblo of Cruz de Tea, near Granadilla, and surrounded by beautiful countryside. It is set in over 80,000m² of land and has a fully working farm producing potatoes and other fruits and vegetables. A three bedroom property, as well as a pretty one/two bedroom farmhouse and other outbuildings, make up the property.

Ref: OUT01146

Price: €950,000 (approx. £805,000)

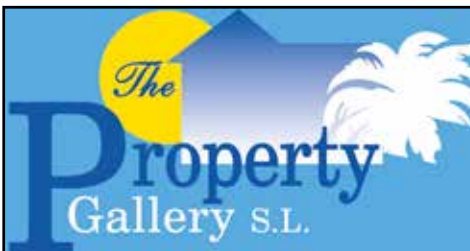

Address: C/ Colon, C.C. Centro Playa, Local 9,
Puerto Colon, Las Americas, Adeje 38660

Phone: 922 719925

E: info@thepropertygallery.com

www.thepropertygallery.com



ALDEA BLANCA



Refurbished bungalow with 2 large bedrooms, modern kitchen, sunny terrace, communal pool.

Ref: C1957

€159,000

PARQUE DE LA REINA



Top floor duplex apartment, 2 bedrooms, 2 bathrooms, lounge-diner, independent kitchen, sauna, terrace, garage space & store rooms. Communal pool.

Ref: D1895

€178,000

VILAFLORES



Very attractive 350 year old Canarian village house, totally renovated to a high standard. 3 bed, 2 bath, on 1.000 m2 plot.

Ref: D1230

€299,000

NEW DEVELOPMENT!

INSIGNE, ROKABELLA
*** LUXURY VILLA ***



- Single family villas with private pool
- 3 bedrooms all with en suite bathrooms
- Open plan kitchen and dining area
- Private entrance and lift
- Private garage
- Air conditioned

Ref: D1842

from €849,000

LOS NARANJOS, SAN EUGENIO ALTO



Luxury 3 bed apt with open plan kitchen, diner, spacious lounge, large terraces with gazebo, jacuzzi & sunbathing area. Closed garage. Communal pool.

Ref: D1847

€550,000



**NEW CASHBACK
CAMPAIGN FOR
EXPATRIATE
CUSTOMERS!**

SAN EUGENIO ALTO



Stunning detached villa with constructed area of 695 m2 situated in elevated position with amazing views. Must be seen!

Ref: D1876

€1,950,000

renovated and furnished offering a spacious & modern living area. Comprising of an open plan fitted and equipped kitchen, lounge, double bedroom with fitted wardrobes, bathroom and balcony. Also included is a private garage of 20m². Secure and well maintained complex with communal pool and gardens. View... For full information see website or contact:
Ref: 7650 | Clear Blue Skies SL | 922 714 772

Las Americas, Apartment

€165,000

1 bed · Fifth floor apartment with lift access in very central area of Playa de las Americas. This one bedroom apartment has a large living room with American style kitchen and balcony and bathroom. Just a five minute walk to the beach front of Playa de las Americas and surrounded by bars, restaurants and shops. Fantastic location and an ideal holiday apartment o... For full information see website or contact:

Ref: AP0513 | Tenerife Island Rentals and Buy Tenerife | Sales: 922 751072

Los Cristianos, Apartment

€165,000

1 bed · Castle Harbour is a well maintained touristic complex in a popular area of Los Cristianos, the apartment is fully furnished and offers a twin bedroom with fitted wardrobes, bathroom, open plan fitted kitchen and lounge. The sunny balcony enjoys a view over the pool & out to sea. Many on site facilities including reception, heated swimming pool, lift to all... For full information see website or contact:

Ref: 7654 | Clear Blue Skies SL | 922 714 772

Palm Mar,

€165,000

2 bed · Apartment for sale in complex in Palm Mar, in Arona municipality. This apartment comprises of two bedrooms, bathroom, open plan fitted kitchen, living room and terrace. Sold unfurnished. Garage space and sotrage room in the underground parking included in the price. Palm Mar is a desirable area on the coast in constant expansion.

Ref: 6982 | Clear Blue Skies SL | 922 714 772

Playa Paraiso,

€164,000

1 bed · ♦ Location: Central, Close to amenities, Close to the beach, Close to the coast ♦ Close to: Medical Facilities, Restaurants/Bars/Cafes, Shops, Transport, Coast ♦ Views: Sea, Garden, La Gomera, Pool, Mountain ♦ Rooms: Hall/ Entrance, American Style Kitchen, Bathroom ♦ Quality: Furnished, Bright ♦ Outside: Terrace ♦ Parking: Off street parking ♦ Community fa... For full information see website or contact:

Ref: 1A3339 | Property Alliance SL | 922 777 747

Amarilla Golf, Duplex

€160,000

2 bed · Location: Exclusive development, Gated community, Central, Golf development, Close to amenities, Popular urbanisation, Close to restaurants/bars/cafes, Close to the coast. Views: Mountain, Golf. Additional: Limited availability, Viewing recommended. Rooms: Ensuite, Fitted wardrobes, Lounge and dining area, American style kitchen, Bathroom. Quality: Qualit... For full information see website or contact:

Ref: 572-A2 | Island Estates | 922 790 767

Las Americas, Apartment

€160,000

1 bed · A rare opportunity to purchase a fantastic 1 bedroom apartment in the heart of Playa de las Americas, comprising a double bedroom with fitted wardrobes, fully fitted American style kitchen, living room with dining area, bathroom and terrace with nice pool views and coastal sea views.

Ref: 7553 | Clear Blue Skies

MBS Physiotherapy Tel: 638 918 684

- ✓ Therapeutic Massage
- ✓ General Physiotherapy
- ✓ Cervical Pain
- ✓ Neurological Physiotherapy
- ✓ Bobath Method
- ✓ Perfetti Method
- ✓ Kinesiotaping
- ✓ Neoromuscular Bandage
- ✓ Dry Needling
- ✓ Neurodynamic Techniques
- ✓ Functional Recovery
- ✓ Electrotherapy

Ma Milagros Sancho Martin, Col. No: 117 Carretera General Guaza, No 9, GUAZA Monday – Friday 9am – 1pm, 3pm – 6pm

SL | 922 714 772

Aldea Blanca,

€159,000

2 bed · Very nice, part-furnished, 2 bed, 2 bath (1 en suite) bungalow-style property on quiet residential complex with access via electrically-controlled security gates, swimming pool and off-road parking. The bungalow has a lounge/dining area, American-style fitted kitchen, conservatory and a large, sunny wraparound terrace/garden. This is a lovely family home ... For full information see website or contact:

Ref: S-02 1377 | Tenerife Prime Property | 922 703 725

San Eugenio Alto,

€158,000

1 bed · ♦ Location: Popular urbanisation, Gated community ♦ Close to: Restaurants/Bars/Cafes, Medical Facilities ♦ Views: Sea ♦ Rooms: Fitted wardrobes, Open plan kitchen ♦ Quality: Good condition, Furnished ♦ Features: Security shutters, Sun blinds ♦ Outside: Large Terrace, Sunny Terrace ♦ Parking: Street parking ♦ Community facilities: Swimming pool, Pool Bar ♦... For full information see website or contact:

Ref: 1A3336 | Property Alliance SL | 922 777 747

Los Abrigos,

€157,500

2 bed · Lovely 2 bed, 1 bath apartment being sold fully furnished on the first floor with an American style fully equipped kitchen, spacious lounge, air conditioning and a 6m² balcony. There is also a parking space in the underground community garage.

Ref: S-02 1355 | Tenerife Prime Property | 922 703 725

Palm Mar,

€157,500

1 bed · ♦ Location: Close to amenities, Close to the beach, Close to the coast ♦ Close to: Beach, Coast, Restaurants/Bars/Cafes ♦ Views: Mountain, Sea, La Gomera ♦ Rooms: Hall/ Entrance, American Style Kitchen, Lounge and dining area, Bathroom ♦ Quality: Furnished ♦ Features: Lift ♦ Outside: Terrace ♦

Ref: 1A3299 | Property Alliance SL | 922 777 747

Parque de la Reina, Apartment

€152,000

2 bed · Two bedroom apartment located on the first floor with garden views. Large living

dining room with enclosed balcony for an additional sitting area, independent fitted kitchen and washing room, two double bedrooms the master with ensuite and further family bathroom, both bedrooms have fitted wardrobes. The property also comes with a parking space and large ... For full information see website or contact:

Ref: AP0521 | Tenerife Island Rentals and Buy Tenerife | Sales: 922 751072

Golf del Sur,

€150,000

2 bed · Excellent 2 bedroom apartment for sale in the frontline complex Aguamarina on Golf del Sur. The apartment is sold fully furnished and equipped. Great residential complex with lifts and a communal pool.

Ref: AP218-AG | Tenerife Belfin Properties | 692 146808

Los Abrigos,

€150,000

2 bed · Location close to restaurants/bars/cafes, close to shops, close to transport Rooms independent kitchen Quality unfurnished, good condition Outside ... For full

Currencies Direct

Call Donna in our Los Cristianos office +34-922 971 781 or Carol on +34-687 906 607

information see website or contact:

Ref: 138-A2 | Island Estates | 922 790 767

€149,999 - €100,000

Las Chafiras, Apartment

€149,950

2 bed · Recently refurbished two bedroom one bathroom apartment in Las Chafiras. Two good sized bedrooms and a bathroom with walk in shower. Separate fitted kitchen. Communal roof terrace and garage space with trastero. Situated in a good location close to supermarkets, large shops and park areas. The property is being sold partly furnished.

Ref: AP0533 | Tenerife Island Rentals and Buy Tenerife | Sales: 922 751072

Golf del Sur, Bungalow

€149,500

1 bed · Clear Blue Skies are delighted to offer for sale a 1 bedroom bungalow located on the select complex of The Palms, Golf Del Sur. This bright and spacious property is very close to the swimming pool and is partially furnished with fitted kitchen, one bedroom, 1 complete bathroom and an extra WC room. The large double bedroom comes with fitted wardrobes, te... For full information see website or

contact:

Ref: 7425 | Clear Blue Skies SL | 922 714 772

Tenbel,

€149,000

2 bed · Two bed, two bath terraced bungalow located in quiet area of Ten Bel in Costa Del Silencio.

Ref: 1814 | Homes & Away | 922 737 044

Costa del Silencio,

€148,000

1 bed · ♦ Location: Popular urbanisation, Close to the Harbour, Gated community, Close to the beach, First line to the coast, Close to amenities ♦ Close to: Transport, Shops, Schools, Restaurants/Bars/Cafes, Medical Facilities, Coast ♦ Views: Teide, Sea, Pool, Garden ♦ Rooms: W. C., Bathroom, Fitted wardrobes, American Style Kitchen, Hall/ Entrance ♦ Quality: Brig... For full information see website or contact:

Ref: 1A3294 | Property Alliance SL | 922 777 747

Playa San Juan,

€145,000

1 bed · Belfin Property brings you this great 1 bedroom apartment located in a small residential complex of only 10 apartments. Excellent location only a few steps from the sea front. The complex is very well kept and has lifts. This comes with 2 parages spaces in the communal garage. Playa San Juan is a lovely coastal town with the best climate on the island!

Ref: AP116-BP | Tenerife Belfin Properties | 692 146808

San Eugenio Alto,

€145,000

1 bed · LAST UNITS! Fantastic opportunity to purchase a holiday apartment in a great complex in San Eugenio. A selection of 1 bedroom apartments starting from 145,000 euros! Don't miss this one! Get yours with the best location and best views!

Ref: AP120-HP | Tenerife Belfin Properties | 692 146808

Playa Fanabe, Apartment

€142,000

3 bed · ♦ Location: Central, Close to amenities, Quiet location ♦ Close to: Medical Facilities, Restaurants/Bars/Cafes, Schools, Shops, Town, Transport ♦ Views: Mountain, Sea ♦ Rooms: Kitchen diner, Family Bathroom, W. C. ♦ Quality: Part furnished, Refurbished ♦ Outside: Sunny Terrace ♦ Parking: Street parking ♦ Community facilities: Gardens ♦

Ref: 3A2490 | Property Alliance SL | 922 777 747

San Eugenio Alto,

€138,000

1 bed · Two 1 bedroom apartments for sale in the popular Laguna Park 2 complex. The apartments consist of 1 bedroom, bathroom, open plan kitchen and a lounge and a terrace. Great holiday complex with a large pool area, pool bar and

San Eugenio Alto,

€138,000

1 bed · Two 1 bedroom apartments for sale in the popular Laguna Park 2 complex. The apartments consist of 1 bedroom, bathroom, open plan kitchen and a lounge and a terrace. Great holiday complex with a large pool area, pool bar and

tennis court. There is also a minimarket on site. Great holiday apartment. Prices 138.000 and 149.000 euros.

Ref: AP109-HP | Tenerife Belfin Properties | 692 146808

Costa del Silencio,

€138,000

1 bed · ♦ Location: Close to amenities, First line to the coast, Gated community, Popular urbanisation, Touristic Area ♦ Close to: Restaurants/Bars/Cafes, Shops, Transport, Coast ♦ Views: Teide, Mountain ♦ Rooms: Open plan kitchen, Fitted wardrobes ♦ Quality: Furnished, Good condition ♦ Features: Satellite system ♦ Outside: Terrace ♦ Parking: Street parking ♦ Com... For full information see website or contact:

Ref: 1A3348 | Property Alliance SL | 922 777 747

Los Abrigos, Apartment

€135,000

3 bed · 2/3 bed top floor apartment in central San Blas location.

Ref: 2056 | Homes & Away | 922 737 044

Playa San Juan,

€133,000

2 bed · ♦ Location: Central, Close to the beach, Close to amenities ♦ Close to: Beach, Coast, Medical Facilities, Restaurants/Bars/Cafes, Shops, Transport, Town, Harbour ♦ Views: Sea ♦ Rooms: Hall/ Entrance, American Style Kitchen, Fitted wardrobes, Bathroom ♦ Quality: Furnished ♦

Ref: 2A3364 | Property Alliance SL | 922 777 747

Costa del Silencio, Duplex

€132,000

2 bed · ♦ Location: Residential Area, Gated community, Close to the coast, Close to amenities ♦ Close to: Shops, Transport, Restaurants/Bars/Cafes ♦ Views: Garden ♦ Rooms: Utility room, Fitted wardrobes, Open plan kitchen ♦ Quality: Spacious accommodation, Refurbished, Renovated, Immaculate condition, Furnished ♦ Outside: Sunny Terrace ♦ Parking: Street parking ♦ ... For full information see website or contact:

Ref: 2D3436 | Property Alliance SL | 922 777 747

Golf del Sur, Apartment

€129,000

1 bed · One bed corner apartment with large terrace and excellent sea views. Close to all amenities.

Ref: 2052 | Homes & Away | 922 737 044

San Eugenio Alto,

€125,000

1 bed · Beautifully furnished, 1

furnished and has a fully equipped kitchenette, bathroom, lounge, terrace and community swimming pool. These studios are an ideal holiday home/ investment.

Ref: S-00 1373 | Tenerife Prime Property | 922 703 725

Golf del Sur,

€111,500

1 bed · Spacious, newly refurbished and furnished 1 bed, 1 bath top floor apartment on popular complex with pool, close to all amenities. This property is one of the large 1 beds on the complex which has a large bedroom and an alcove, which many people make into a second bedroom. Lounge/diner and nice terrace with sea views. Extras incl. aircon.

Ref: S-01 1388 | Tenerife Prime Property | 922 703 725

Costa del Silencio,

€110,000

1 bed · Fantastic, fully furnished, 1 bedroom, 1 bathroom apartment with extra-large terrace and great sea views. Well-run complex with pool Ideal holiday home/ investment.

Ref: BaldeMar | MK Properties | 922 751 / 630 994991

Adeje Town,

€110,000

2 bed · Apartment with 2 bedrooms, 1 bathroom, American kitchen, furnished with views. Close to everything. Ample parking in front. In quiet area with gardens. Ideal investment.

Ref: Adeje Pueblo | MK Properties | 922 751 / 630 994991

Golf del Sur,

€105,000

1 bed · Fully refurbished and furnished 1 bed, 1 bath apartment with air conditioning, newly fitted kitchen and refurbished bathroom. This apartment is on the 3rd floor and there are lifts throughout the complex. Views from the terrace onto the community swimming pool.

Ref: S-01 1343 | Tenerife Prime Property | 922 703 725

UNDER €100,000

Las Galletas,

€94,500

1 bed · 3rd floor 1 bedroom, 1 bathroom apartment with lounge and American style kitchen with a large sunny terrace and fabulous sea views and very low community fees.

Ref: S-01 843 | Tenerife Prime Property | 922 703

Studio 4 Decor

NEW STORE NOW OPEN!

ACROSS THE ROAD FROM OUR OLD ONE IN LOS ABRIGOS

SEE OUR MAIN ADVERT ON PAGE 34

bedroom, 1 bathroom apartment in popular complex with pool. Good views.

Ref: Paradise Court | MK Properties | 922 751 / 630 994991

Chayofa,

€118,500

Large studio apartments for sale (prices from 99.950). Studios being sold fully

725

Costa del Silencio,

€80,000

Ground floor studio apartment being sold fully furnished with lounge, American style fully fitted kitchen and an enclosed terrace made into bedroom area.

Ref: S-00 1358 | Tenerife Prime Property | 922 703 725

**DO YOU FEEL
CONFIDENT WHEN
BUYING OR SELLING
A PROPERTY?**



We have the largest network of Real Estate Agencies in the South of Tenerife - **32 offices** and more than **150 sales agents** all able to offer your property at the same time!

THE ASSOCIATION COUNTS ON EXPERIENCED LAWYERS AND TAX ADVISERS IN THE SOUTH OF TENERIFE.

IF YOU WOULD LIKE TO BUY, SELL, OR RENT A PROPERTY WITH COMPLETE CONFIDENCE, PLEASE DO NOT HESITATE TO CONTACT ANY OF OUR ASSOCIATION MEMBERS.

CALL US! WE HAVE BUYERS WAITING!

Alliance Group Hofman Estates S.L. – 922 777 747
Amulet Property Development Group – 922 083 415
Atlantic Properties – 922 795 560
Belfin Property – 692 146 808
Canarias Global Invest – 922 791 951
Castle Properties – 922 718 425
Compas Inmobiliaria – 922 702 504
DAM Tenerife – 922 788 331
Deknock – 658 905 539
Gigi Inmobiliaria – 922 734 151

InmoCarolina 2006 Real Estate – 922 717 389
Los Menceyes Properties – 922 732 173
Luxury World Properties SLU – 922 791 081
Melisofi Consulting S.L. – 922 788 125
Paul Ruane-Los Gigantes Properties – 922 861 313
Premier Properties Tenerife – 695 822 120
Property Center Q-Rort Canarias – 607 775 394
Ideal Homes Tenerife – 678 586 099
San Eugenio Real Estate – 922 719 941
Smilo Properties – 661 357 611

Tenerife Properties for Sale (Belgaten SL) – 607 387 545
Tenerifehome – 922 783 066
Tenerife Property Partners – 922 707 205
Tropical Country House – 922 719 643
Tenerife Property Shop – 922 714 700
TPN Tenerife – 672 142 237
Visaverde CSSL – 922 794 214
Vym Canarias - 922 787 210
Wady Properties – 922 712 254

TENERIFE SOUTH REAL ESTATE ASSOCIATION

Avda. Antonio Dominguez No 5,
C.C. ZentralCenter, 5th Floor, Office 2,
PLAYA DE LAS AMERICAS 38660
(Asesores: Laynez & Fornies)

INTEGRITY · SECURITY · TRANSPARENCY

Tenerife Prime Property

Amarilla Golf, Fairways Club



Lovely, fully renovated and furnished and equipped 1 bed, 1 bath apartment on popular, sought after holiday complex with beautiful pool and pool bar area. The property has a lounge/dining area, American-style kitchen and a sunny terrace and is located close to all amenities, the sea front and Amarilla championship golf course. Holiday rental income (all legal) in 2019 was €10,000 despite the apartment not being available during refurbishment. More details information on request.

S-01 1405

€143,000



PROPERTIES IN ALL AREAS REQUIRED FOR LONG TERM RENTAL - CLIENTS WAITING!

Amarilla Golf, Pinehurst 1 bed



Lovely, fully refurbished, unfurnished 1 bed, 1 bath 2nd floor apartment on complex with pool and bar/restaurant. The property enjoys views over the golf course to the sea, has a lounge/dining area, American-style fitted kitchen and a terrace which can be closed off to create additional living space.

S-01 1400

€132,000

Los Cristianos, Dinastia



Spacious, fully furnished 2 bed, 2 bath (1 en suite) apartment on popular residential complex with lovely pool and sunbathing terrace. The property has a lounge/dining area, American kitchen and a large terrace. There is lots of storage space and close to all amenities.

S-02 1387

€264,950

Golf del Sur, Las Adelfas II



Spacious, part-furnished, 2 bed, 2 bath corner villa in complex with pool. The property has a large lounge/dining area, kitchen, and a wrap-around terrace which enjoys lovely sea, mountain and golf course views.

S-02 1342

€218,500

Golf del Sur, Las Adelfas I



Spacious, fully furnished 2 bed, 2 bath (1 en suite) house on popular holiday complex with heated pool and restaurant and located close to all amenities. The property has a lounge-diner, independent fitted kitchen, front garden, large rear garden and terrace and a private, sunny rooftop terrace with excellent views.

S-02 1396

€249,950

Fañabe, Lagos de Fañabe

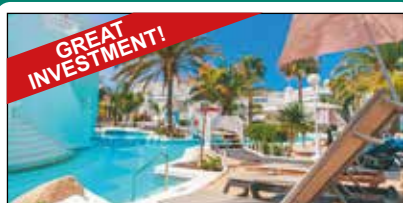

Beautiful, fully furnished 1 bed, 1 bath apartment on sea front, 'Touristic' complex with 3 pools, just 70 metres from the beach. The property has a lounge/diner, open kitchen, sunny terrace and private parking. Holiday occupancy is 60%+ (at c€500/€950 per week).

S-01 1379

€300,000

Los Cristianos, Parque Tropical II



Large, part-furnished, 2 bed, 2 bath duplex apartment in sought after complex with lovely pool area. The property has a lounge/diner, American-style kitchen, small front garden and a large terrace off the lounge overlooking the pool. Needs minor refurbishing.

S-02 1150

€250,000

Torviscas Alto, Los Altos del Roque



Well-presented, fully furnished 1 bed, 1 bath ground floor apartment on popular residential complex with pool and sunbathing terraces. The property, in an elevated position with no one above, has a lounge-diner, open plan kitchen, a sunny terrace overlooking the pool and a parking space in the underground garage.

S-01 1363

€140,000

Oroteanda Bajo



Stunning, fully furnished & equipped, 5 bed, 3 bath (master en suite) detached villa with heated pool on 2,000sqm plot. There is a garage for 4 cars and aircon and central heating throughout. This is a property has to be seen to appreciate all that it has to offer.

S-05 1380

€1,250,000

Tel: 922 703 725 / 627 230 360

carolhale.tpp@gmail.com • tenerifeproperty.com

Tenerife Prime Property

Amarilla Golf, Augusta Park



Beautiful, ground floor 1 bed, 1 bath apartment being sold fully furnished. There is a lounge and fully equipped American style kitchen, air conditioning, electric shutters over windows and an 8m2 terrace overlooking the community swimming pool. (Pool to be heated this year). Low community fees. This is a lovely well maintained apartment.



S-01 1354

£142,000 sterling



PROPERTIES IN ALL AREAS REQUIRED FOR LONG TERM RENTAL - CLIENTS WAITING!

Amarilla Golf, Pinehurst

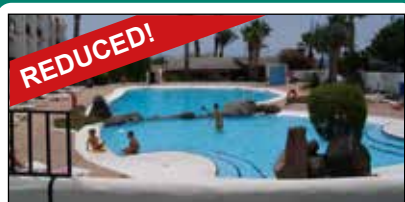

Beautifully decorated, fully furnished, 2 bed, 1 bath ground floor apartment on popular complex with pool, close to all amenities. This spacious (77sqm) property has a lounge/diner, American-style kitchen and a large sunny terrace overlooking the pool and gardens. Com. Fees €306 every 2 months.

S-02 1384

£160,000 Sterling

Playa de las Americas, Jacaranda



Lovely, spacious, fully refurbished, 3 bed, 1 bath penthouse apartment with sea views on popular holiday complex with pool, close to all amenities and just 100 metres from the beach. The property has a lounge/dining area, American-style fitted kitchen and large sunny terrace.

S-03 1398

€299,000

Golf del Sur, Winter Gardens



Lovely 2 bed, 2 bath (1 en suite) apartment on popular complex with pool and pool bar, and bowling green. Tastefully furnished with separate, fully equipped kitchen, small utility room, and a large lounge leading with good-sized terrace off.

S-02 1352

€235,000

Los Cristianos, Dinastia



Beautiful, fully furnished, ground floor 2 bed, 2 bath (1 en suite) apartment with an exceptionally large terrace. This apartment is very tastefully furnished and has a fully equipped kitchen. There are lifts throughout the complex and there is a community swimming pool and pool bar.

S-02 1348

€285,000

San Miguel, El Roque

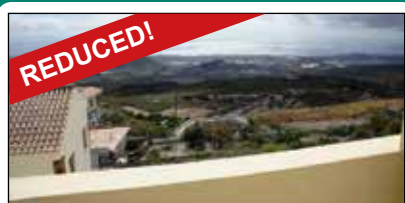

Spacious, fully furnished, 4 bed, 3 bath (1 en suite) house on a plot of 750m2 with large lounge, separate fully fitted kitchen, games room and two roof terraces. This is a lovely family home in a quiet Canarian village.

S-04 1335

€299,950

Playa Paraiso, El Horno



Beautiful, fully furnished 2 bed, 1 bath 1st floor apartment on sought after complex with heated pool. This spacious property enjoys sea and mountain views, has a lounge/diner, American-style kitchen, large sunny terrace and a secure garage space and storeroom. Community fees €57/month.

S-02 1401

€263,000

Roque del Conde, Los Altos del Roque



Lovely, spacious, fully furnished and equipped 4 bed, 4 bath (2 en suite) semi-detached townhouse with own swimming pool in quiet, sought after complex situated close to amenities. The property, which enjoys lovely sea views, has a lounge/diner, independent fully fitted kitchen, terrace/garden, and double garage.

S-04 1395

€399,950

San Eugenio Alto, Island village



Very nice, fully furnished and equipped studio apartment on popular holiday complex with lovely heated pool and close to all amenities. The property has a lounge/sleeping area, American-style fitted kitchen and good-sized, sunny terrace with sea views. Community fees €75 per month

S-00 1402

€134,950

Tel: 922 703 725 / 627 230 360
 carolhale.tpp@gmail.com • tenerifeshopproperty.com

Los Abrigos
 www.studio4decor.net
 Info@studio4decor.net
 922 749 793 / 626 955 725



MONDAY – FRIDAY,
 9.30AM – 1.30PM,
 AND 3.00PM – 6.00PM
 SATURDAY BY APPOINTMENT

QUALITY FURNITURE TO SUIT ALL BUDGETS



STUDIO4DECOR offers a unique, one-on-one service aimed at taking the stress out of furnishing your property. From single items such as lamps, mirrors, curtains, pictures or ornaments to complement your new decor, we can help.

- ✓ Full re-upholstery service available
- ✓ Bespoke sofas, headboards and pelmets
- ✓ Beautiful made-to-measure curtains
- ✓ 1,000's of fabric swatches to choose from

Call into our Los Abrigos Showroom (29 Calle La Marina, Edificio Bogavante) and let us help turn your ideas into reality.

Beautiful interiors at a price you can afford!

Euro fluctuates in the face of EU 'coronabonds' division

Coronavirus developments and March's economic reports have continued dictating market sentiment in recent weeks, resulting in significant currency volatility.

The GBP/EUR exchange rate rose from lows of €1.06 to €1.14 while EUR/GBP dipped to €0.87. Meanwhile, GBP/USD recovered from 1.14 to 1.24, while EUR/USD fell from highs of 1.11 to around 1.07. After sliding for most of March, the pound put on a strong performance last week, edging higher against the euro and US dollar. Sterling benefited despite weak services and manufacturing PMIs, both of which fell to record lows as the nationwide lockdown took its toll on the British

economy. The euro, meanwhile, struggled in the face of German recession fears and a lack of cohesion within the European Union over coronabonds, a joint debt project that was rejected by Germany, Netherlands and other northern states. The US dollar put on a mixed performance following the US Federal Reserve's massive \$2 trillion stimulus package but was largely bolstered by investors' demand for safe-haven currencies. Even record-high unemployment claims failed to undermine USD exchange rates. The poor US employment data increased concerns for the global economic outlook, lending further support to safe-havens. However, a decline in the number of coronavirus cases in Europe lead to

a return of risk appetite at the beginning of April. The coronavirus will continue to dictate market sentiment in the weeks ahead, with investors paying close attention to the number of infections and deaths. The euro could start pushing higher if the figures keep declining in Spain and Italy. Meanwhile, the pound could come under pressure from Thursday's UK industrial and manufacturing data, which is forecast to show output declined even before the coronavirus lockdown. Downing Street's announcements on the nation's coronavirus situation will also continue to influence the pound this week. Any indications of an extension to the lockdown could



prove GBP-negative. The US dollar will also remain reactive to the development of the US coronavirus crisis. Currencies Direct are operating normally, without disruption to service, security or normal transfer times. We're here to talk currency whenever you need us. Since 1996

we've helped more than 325,000 customers with their currency transfers, so get in touch if you want to know more about the latest news or how it could impact your currency transfers. Take care, stay home, and stay safe.

+34 922 971 781
 canaries@currenciesdirect.com
 currenciesdirect.com



Helping you start your Spanish adventure

With Currencies Direct, you'll get more from your new life in the sun with fast, free currency transfers and bank-beating exchange rates.

Whether you're buying foreign property, transferring a pension overseas or moving money home, we're here to make sure you always get a great deal.

Contact us for more information

Tenerife Calle Oregón 5, Residencial los Seres, Local 6,
Los Cristianos, Arona, 38650, Tenerife.

canaries@currenciesdirect.com
+34 922 971 781

..... currenciesdirect.com

TENERIFE'S FAVOURITE BRITISH BAKERS

CROQUANT

BRITISH BAKERY & COFFEE SHOPS

IT'S OFFICIAL!
We're **THE BEST** bakery in Tenerife!



Ample free parking

Fresh coffee and snacks on our outside terraces in Los Cristianos and Las Chafiras

Daily Specials

FRESH, NOT FROZEN!

A huge assortment of breads, sausage rolls, quiches, cakes, freshly made sandwiches, hot toasties and wraps, all with a choice of fillings.

NOW AVAILABLE:

HOMEMADE
Toasted teacakes, potato cakes and savouries
ALL FRESHLY BAKED IN-STORE!



Baked under Licence – Hovis – **THE ORIGINAL, multi-seed granary bread!**

FIND US AT:

LOS CRISTIANOS:
Avenida Los Playeros
(Main street)
Tel: 922 798 133

LAS CHAFIRAS:
Fundadores
Co-operativa
No. 74

BOTH SHOPS OPEN DAILY FROM 7.00AM – 9.00PM (MONDAY – SATURDAY), AND 8.00AM – 3.30PM (SUNDAYS)

LAS CHAFIRAS BOOK SHOP

NOW ONLINE!
www.laschafirasbookshop.com

The Bookshop is located at Calle Luciano Bello Alfonso No 5 in Las Chafiras (behind and above Pit Team Sur and the Golf Shop, and opposite Marrero Homes). Books cost just €3.00 but we offer a 'Buy two get one FREE' system and we buy books we don't have for 50 cents each.

We now have more than 10,000 books to choose from, either in the Shop itself, or via the internet (www.laschafirasbookshop.com), where you can 'browse' our inventory and order – we will be happy to deliver to anyone not able to get in.

Should you come to the shop and no one is in, just call us on either 609 714 276 or 627 230 360 – we're never very far away and will get back as fast as we can – while you have a coffee at one of the many cafés nearby!



ACT

+34 922 736 728

APP for mobile and laptop
NOW AVAILABLE!

...looking after your Digital World!

T: 922 736 728

WATCH LIVE UK TV NOW **ACT**

W: act-tenerife.com • Mon/Fri: 09.30 – 17.30hrs

T: 610 800 689
(10am - 6pm, Mon - Fri)

info@canaryvoip.com
canaryvoip.com



Computer Services:
PC Sales Repairs & Maintenance

Networking:
Network Installation & Maintenance

Home and Business:
VoIP Services
Network Installations

The Prestige Group

Agustin Millares 20, Armeñime, Adeje 38678

Interior & Exterior Sun Blinds

Tenerife's leading specialist in the manufacture, repair and installation of all types of awnings, canopies, interior and exterior blinds - manual or electric.



The Prestige Group is a trading name of JAC Enterprises S.L.

Tel: 922-740888

www.theprestigegroup.es

info@theprestigegroup.es

Showroom open
Monday to Friday:
9.00am to 5.00pm
Situated opposite the BP
garage in Armeñime

Outdoor Furniture

We offer a large range of exclusive garden and terrace furniture in a wide variety of styles, designs, fabrics and colours. We also have parasols and cushions.



Roller Shutters, Grilles & Garage Doors

Specialists in the manufacture, repair and installation of industrial and domestic shutters, security grilles and garage doors – electric or manual.





RESIDENCIA HEALTH POLICY

- ELITE COVER e.g. Age: 20 - 45€ per mth
- ELITE COVER e.g. Age: 40 - 60€ per mth
- ELITE COVER e.g. Age: 60 - 93€ per mth

SMALL BUSINESS/COMPANY POLICY

- ELITE COVER e.g. Age: 20-49 - 48€ per mth
- ELITE COVER e.g. Age: 50-54 - 57€ per mth
- ELITE COVER e.g. Age: 55-60 - 68€ per mth

NB Sample prices. Terms & Conditions Apply



CAR INSURANCE



	Third Party	TPFT	Comp
Renault Clio 1.2	209€	210€	270€
Seat Ibiza 1.4	209€	215€	270€
Ford Fiesta 1.6	209€	220€	270€

€ - CASH BACK - €

The more policies you do, the more you save!



For existing Liberty Seguros customer - 60€ per policy
 For new customers, 30€ for 1st policy then 60€ per policy
 (Minimum premiums, Terms & Conditions apply – NEW, not cancelled or replaced policies)
Offer valid 29/01 - 26/03/2020 for all NEW qualifying policies



Great Prices & Guarantees
 Policies in English, German or Spanish
 and much more ...



HOME INSURANCE - in Safe Hands

CONTENTS		BUILDINGS		Contents & Buildings	
Cover	- COST	Size m ²	- COST	Covers	- COST
6,000€	- 83€	50	- 85€	12,500€ & 50 m ²	- 127€
12,500€	- 84€	75	- 92€	15,000 & 100 m ²	- 137€
15,000€	- 84€	100	- 103€	20,000 & 200 m ²	- 180€
20,000€	- 85€	125	- 115€	30,000 & 300 m ²	- 238€
25,000€	- 86€	200	- 141€		
30,000€	- 87€	300	- 182€		

NB Sample prices. Terms & Conditions Apply

661-908-980



Tenerife Insurance Services SL

Calle Clara Toledo Gomez Local A, Las Chafiras & Av el Palm Mar, Palm Mar

922-735-672

OFFICIAL REGISTRATION OF ALTERATIONS OR EXTENSIONS TO PROPERTIES



I am often asked by property owners if it is possible to get official Town Hall recognition for works carried out some time ago without appropriate Building Licenses. ie Works which have enlarged a property or even created a wholly new property. They are usually very concerned that they

could at some stage in the future be fined or even be faced with tearing down that which has been created or altered.

In many cases the answer is yes, you can have the works officially recognized, providing a number of conditions are met:

The works carried out

must not occupy a protected "green" zone, a public space, a public highway or walkway or a protected site of natural beauty. Enquiries in your local Town Hall should confirm this point one way or the other.

At least four years must have passed from when the works were completely finished.

That no-one has lodged an official complaint (Denuncia) against the works, which has then been ignored and left unresolved.

That your property does not form part of a community where the limit of development has been reached

In Spanish what needs to be applied for is a "Certificado de prescripción de infracción urbanística" or Certificate of recognition of a planning infraction.

The paperwork needed to apply for this is normally put together by a Technical Architect or Architect. This is because aerial photographs,

plans, a description and detailed measurements of the property both in its original and altered state are required, together with the normal accompanying documents such as copy of title deed (escritura), NIE and IBI receipts. Also, within the submission, the same professional must sign a declaration to the effect that the works to the property were completed more that 4 years ago and that the property complies with minimum habitation standards and is structurally stable.

Depending on the Town Hall applied to and complications of consultations to affected parties this process can take from 3 to 6 months. In certain cases, such as where a property is adjacent to the sea, the Spanish Coastal Department will need to be consulted to ensure that there has not been an encroachment into the protected coastal zone. If this is the case it is highly likely that the application will be refused.

Once the application to

the Town Hall has been approved, their administration charges paid and the Certificado de prescripción de infracción urbanística has been obtained, this can then be used to draft a complementary property deed. This deed differs from the original property deed as it declares that i) new works have been carried out to the property, ii) describes what has altered and perhaps most importantly iii) defines the new revised built area that the property occupies. Once this deed has been signed before a Notary, taxes can be paid to the Hacienda and then it can then be presented to the Registro de la Propiedad (Spanish Land Registry) where the notarized deed can be registered.

The importance of registering any such improvements is that when the property comes to be sold or passed to heirs, and when the customary searches are requested, the one to the Land Registry will show and describe the distribution and

floor area of your property as it actually is. This will make things much clearer and less complicated at a time when delays in rectifying such matters could be costly, time consuming and which could possibly jeopardize a sale.

Also, if you or a potential purchaser is having the property valued to raise a mortgage, the person valuing will discover that part of the property is unregistered and will likely recommend that this be rectified. It could result in the mortgage offered being less than you or a potential purchaser had hoped for.

If you or the previous owner of a property you now own has extended that property and you would like to know if you can progress in the manner described above please do not hesitate to contact me, Philip Wright, Spanish Technical Architect and Chartered Building Surveyor to discuss further. My mobile number is 667 757 323.

MARRERO HOME

Presents



THE BEST SOFABED YOU CAN BUY!



- COMFORTABLE as a SOFA!
- COMFORTABLE as a BED!

We have more than 25 styles of SOFABED IN STOCK – and in a wide range of FABRICS!

Come and choose your new Sofabed - and we will deliver it to you next day!

WARDROBES

FLOORING

KITCHENS

SOFAS AND SOFABEDS

FURNITURE



922 703 117



Avda. Claudio Delgado Diaz, 103 - Las Chafiras - San Miguel de Abona - TENERIFE



maderasmarrero@maderasmarrero.com



www.maderasmarrero.com

Is sugar really bad for you?



By Jessica Brown, BBC Future

People who eat more sweets are at higher risk of type 2 diabetes, heart disease and cancer... but that may not actually be sugar's fault. BBC Future investigates the latest findings.

Given the current situation, many of us are more interested than ever in how food can (and can't) support our health. To help you sort out fact from fiction, BBC Future is bringing back some of our most popular nutrition stories. Our colleagues at BBC Good Food are also focusing on practical solutions for ingredient swaps, nutritious storecupboard recipes and all aspects of cooking and eating during lockdown.

It's hard to imagine now, but there was a time when humans only had access to sugar for a few months a year when fruit was in season. Some 80,000 years ago, hunter-gatherers ate fruit sporadically and infrequently, since they were competing with birds.

Now, our sugar hits come all year round, often with less nutritional value

and far more easily – by simply opening a soft drink or cereal box. It doesn't take an expert to see that our modern sugar intake is less healthy than it was in our foraging days. Today, sugar has become public health enemy number one: gov-

ernments are taxing it, schools and hospitals are removing it from vending machines and experts are advising that we remove it completely from our diets. It has even been blamed for possibly increasing the risk of contracting infections because it allegedly suppresses the immune system, although in reality



The term 'sugar' includes a broad array of sweeteners, including the fructose naturally found in fruit

the last five years summarised that a diet of more than 150g of fructose per day reduces insulin sensitivity – and therefore increases the risk of developing health problems like high blood pressure and cholesterol levels. But the researchers also concluded that this occurs most often when high sugar intake is

combined with excess calories, and that the effects on health are "more likely" due to sugar intake increasing the chance of excess calories, not the impact of sugar alone. Meanwhile, there is also a growing argument that demonising a single food is dangerous – and causes confusion that risks us cutting out vital foods. Sugar, otherwise known as "added sugar", includes table sugar, sweeteners, honey and fruit juices, and is extracted, refined and added to food and drink to improve taste. But both complex and simple carbohydrates are made up of sugar molecules, which are broken down by digestion into glucose and used by every cell in the body to generate energy and fuel the brain. Complex carbohy-

drates include wholegrains and vegetables. Simple carbohydrates are more easily digested and quickly release sugar into the bloodstream. They include sugars found naturally in the foods we eat, such as fructose, lactose, sucrose and glucose and others, like high fructose corn syrup, which are man-

made. Before the 16th Century only the rich could afford sugar. But it became more available with colonial trade. Then, in the 1960s, the development of large-scale conversion of glucose into fructose led to the creation of high fructose corn syrup, a concentrate of glucose and fructose. This potent combination, above any other single type of sugar, is the one many public health advocates consider the most lethal – and it is the one that many people think of when they think of 'sugar'.

Sugar rush

Consumption of high fructose corn syrup in the US increased tenfold between 1970 and 1990, more than any other food group. Researchers have pointed out that this mirrors the increase in obesity across the country.

Meanwhile, sugary drinks, which usually use high fructose corn syrup, have been central to research examining the effects of sugar on our health. One meta-analysis of 88 studies found a link between sugary drinks consumption and body weight. In other words, people don't fully compensate for getting energy from soft drinks by consuming less of other foods – possibly because these drinks increase hunger or decrease satiety.

But the researchers concluded that while the intake of soft drinks and added sugars has increased alongside obesity in the US, the data only

represents broad correlations.

And not everyone agrees that high fructose corn syrup is the driving factor in the obesity crisis. Some experts point out that consumption of the sugar has been declining for the past 10 years in countries including the US, even while obesity levels have been rising. There also are epidemics of obesity and diabetes in areas where there is little or no high fructose corn syrup available, such as Australia and Europe.

High fructose corn syrup isn't the only kind of sugar seen as problematic. Added sugar, particularly fructose, is blamed for a variety of problems. People who consumed 25% or more of calories as added sugar were more than twice as likely to die from heart disease.

For one, it's said to cause heart disease. When liver cells break down fructose, one of the end products is triglyceride – a form of fat – which can build up in liver cells over time. When it is released into the bloodstream, it can contribute to the growth of fat-filled plaque inside artery walls.

One 15-year study seemed to back this up: it found that people who consumed 25% or more of their daily calories as added sugar were more than twice as likely to die from heart disease than those who consumed less than 10%. Type 2 diabetes also is attributed to added sugar intake. Two large studies in the 1990s found that women who consumed more than one soft

Cont. on page 42



Some researchers believe that once high fructose corn syrup became so common, an obesity crisis was only a matter of time

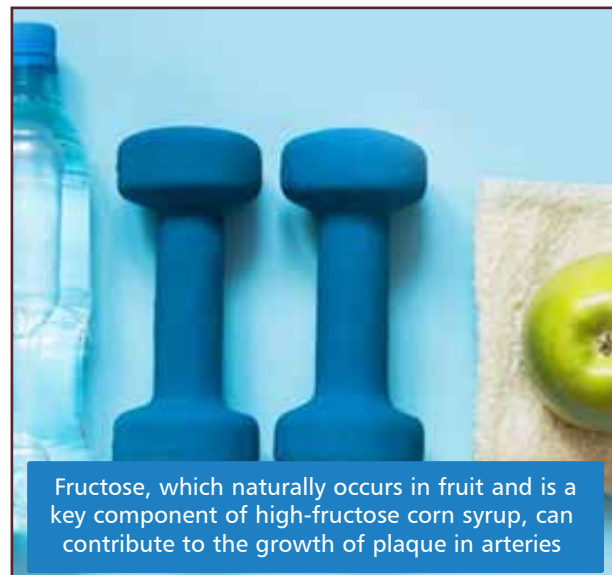

Fructose, which naturally occurs in fruit and is a key component of high-fructose corn syrup, can contribute to the growth of plaque in arteries



Many scientists believe that sugar alone doesn't cause obesity – but that, instead, sugar often is part of a diet with too high of a calorie intake in general.

mueble4you

tenerife

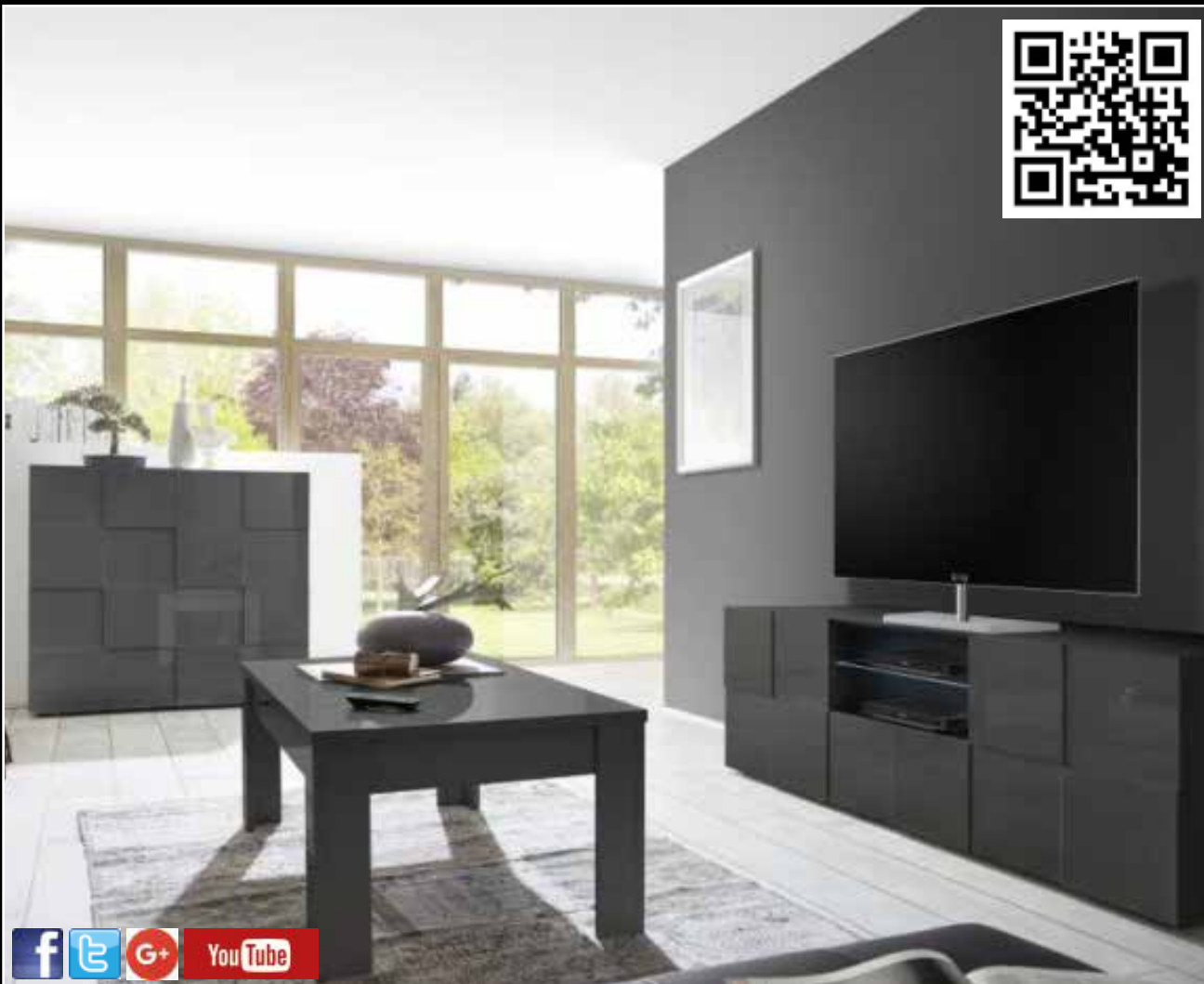

Whole House Packages

Soft Furnishings

Interior Decoration

Including:

Rugs and Carpets, Lights, Vases, Artificial Flowers, Pictures, Mirrors Bedsreads and Throws

Home, Patio & Garden Furniture

New Stock Always arriving!

Including:

Rattan Garden Furniture
Dining Suites
Lounge Suites
Beds and Bedding



EVERYTHING IN OUR SHOWROOM IS AVAILABLE FOR IMMEDIATE DELIVERY!

www.mueble4you.com

OPENING HOURS: Monday - Friday: 10.00am - 8.00pm
Saturdays: 10.00am - 2.00pm

Avda 7 Islas Canarias, No 2,
Poligono Industrial Llano del Camello,
LAS CHAFIRAS

Tel: 922 736 783 / 922 736 930
Email: antiquities.tfs@gmail.com
Email: sales@mueble4you.com

facebook Mueble4you Tenerife



Cont. from page 40
develop diabetes as those who rarely did so.

Sweet nothings?

But again, it's unclear if that means sugar actually causes heart disease or

are associated with these conditions. But clinical trials have yet to establish that it causes them. Sugar also has been associated with addiction... but this finding, too, may not be what it seems. A review published in the British

brain two years compared to those who didn't drink any at all. But Pase explains that since he only measured fruit juice intake, he can't be sure that sugar alone is what affects brain health.

"People who drink



Athletes often consume more sugar than other people, but because they metabolise it during exercise, they still have lower rates of cardiovascular disease

diabetes. Luc Tappy, professor of physiology at the University of Lausanne, is one of many scientists who argue that the main cause of diabetes, obesity and high blood pressure is excess calorie intake, and that sugar is simply one component of this.

"More energy intake than energy expenditure will, in the long term, lead

Journal of Sports Medicine in 2017 cited findings that mice can experience sugar withdrawal and argued that sugar produces similar effects to cocaine, such as craving. But the paper was widely accused of misinterpreting the evidence. One key criticism was that the animals were restricted to having sugar for two hours a day: if you

more fruit juice or soft drinks may share other dietary or lifestyle habits that relate to brain health. For example, they may also exercise less," Pase says. One recent study found that sugar may even help improve memory and performance in older adults. Researchers gave participants a drink containing a small amount of



One study found that consuming two juice drinks per day aged the brain by two years, compared to not drinking any

to fat deposition, insulin resistance and a fatty liver, whatever the diet composition," he says. "In people with a high energy output and a matched energy intake, even a high fructose/sugar diet will be well tolerated." Overall, evidence that added sugar directly causes type 2 diabetes, heart disease, obesity or cancer is thin. Tappy points out that athletes, for example, often have higher sugar consumption but lower rates of cardiovascular disease: high fructose intake can be metabolised during exercise to increase performance.

Overall, evidence that added sugar directly causes type 2 diabetes, heart disease, obesity or cancer is thin. Yes, higher intakes

allow them to have it whenever they want it, which reflects how we consume it, they don't show addiction-like behaviours.

Still, studies have demonstrated other ways in which sugar affects our brains. Matthew Pase, research fellow at Swinburne's Centre for Human Psychopharmacology in Australia, examined the association between self-reported sugary beverage consumption and markers of brain health determined by MRI scans. Those who drank soft drinks and fruit juices more frequently displayed smaller average brain volumes and poorer memory function. Consuming two sugary drinks per day aged the

glucose and asked them to perform various memory tasks. Other participants were given a drink containing artificial sweetener as a control. They measured the participants' levels of engagement, their memory score, and their own perception of how much effort they'd applied.

The results suggested that consuming sugar can make older people more motivated to perform difficult tasks at full capacity – without them feeling as if they tried harder. Increased blood sugar levels also made them feel happier during the task.

Younger adults showed increased energy after consuming the glucose drink, but it didn't affect their mood or memory.



In older adults, consuming a sugary drink may make them more motivated and even happier during a task

Teaspoon of sugar

While current guidelines advise that added sugars shouldn't make up more than 5% of our daily calorie intake, dietitian Renee McGregor says it's important to understand that a healthy, balanced diet is different for everyone. "I work with athletes who need to take on more sugar when doing a hard session because it's easily digestible. But they worry they're going over the guidelines," she says.

For most of us non-athletes, it's true that added sugar isn't crucial for a healthy diet. But some experts warn we shouldn't single it out as toxic. McGregor, whose clients include those with orthorexia, a fixation with eating healthily, says that it isn't healthy to label foods as 'good' or 'bad'. And turning sugar into a taboo may only make it more tempting. "As soon as you say you can't have something, you want it," she says. "That's why I never say anything is off-limits. I'll say a food has no nutritional value. But sometimes foods have other values."

Associate professor at James Madison University Alan Levinovitz studies the relationship between reli-

gion and science. He says there's a simple reason we look at sugar as evil: throughout history, we've demonised the things we find hardest to resist (think of sexual pleasure in the Victorian times). Today, we do this with sugar to gain control over cravings.

"Sugar is intensely pleasurable, so we have to see it as a cardinal sin. When we see things in simple good and evil binaries, it becomes unthinkable that this evil thing can exist in moderation. This is happening with sugar," he says. He argues that that seeing food in such extremes can make us anxious about what we're eating – and add a moral judgment onto something as necessary, and as everyday, as deciding what to eat.

Taking sugar out of our diets can even be counterproductive: it can mean replacing it with something potentially more calorific, such as if you substitute a fat for a sugar in a recipe. And amid the rising debate around sugar, we risk confusing those foods and drinks with added sugar that lack other essential nutrients, like soft drinks, with healthy foods that have sugars, like fruit.

One person who struggled with this distinction is 28-year-old Tina Grundin of Sweden, who says she used to think all sugars were unhealthy. She pursued a high-protein, high-fat vegan diet, which she says led to an undiagnosed eating disorder. "When I started throwing up after eating, I knew I couldn't go on much longer. I'd grown up fearing sugar in all forms," she says. "Then I realised there was a difference between added sugar and sugar as a carbohydrate and I adopted a high-fructose, high-starch diet with natural sugars found in fruit, vegetables, starches and legumes. "From the first day, it was like the fog lifted and I could see clearly. I finally gave my cells fuel, found in glucose, from carbohydrates, from sugars."

While there's disagreement around how different types of sugars affect our health, the irony is we might be better off thinking about it less. "We've really overcomplicated nutrition because, fundamentally, what everyone is searching for is a need to feel complete, to feel perfect and successful," says McGregor. "But that doesn't exist."



Even when sweet foods have little or no nutritional value, they have other values

ALUMINIUM & GLASS

We manufacture and install all kinds of aluminium and glass products.

ARTENGLASS

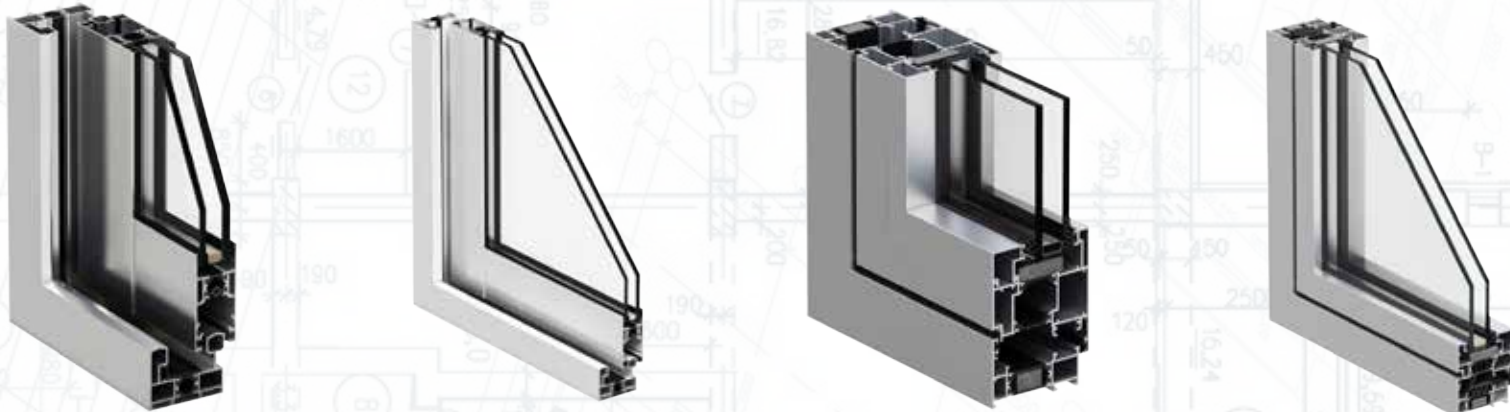

- ALUMINIUM DOORS AND WINDOWS
- GLASS CURTAINS
- KITCHEN GLASS SPLASHBACKS
- CONSERVATORIES
- POOL FENCE SURROUNDS
- AWNINGS AND INTERIOR BLINDS
- ROLLER SHURRERS, etc...

Ctra. General TF, 66 (Local Izquierda, Mom:83), Valle San Lorenzo, Arona
 Tel: **+34 627 906 456 / +34 922 764 187**
info@artenglasstenerife.com

ALUMINIUM & GLASS



www.artenglasstenerife.com



What leader are you? It depends on your parents



By Christian Jarrett, a senior editor at Aeon magazine

Your parents' good intentions might have undermined your confidence – but you can do something about it.

You've probably noticed how some of your colleagues take to leadership roles like a duck to water. They're confident telling others what to do, and happy taking on an ever-growing number of responsibilities. It couldn't be more different for others: bossing around people feels awkward, and a nagging self-doubt shadows every decision. If you're in the latter group, you might wonder why the thought of being a leader fills you with dread, and why you find it so hard to even see yourself as a manager.

As with almost any aspect of human nature, some of the answer comes down to your genetically inherited disposition. If your parents were shrinking violets, the odds are increased that you will be too. But that's far from the whole story. Increasingly, psychologists are realising the important part that early life experiences play. And key here is the way your parents

behaved toward you.

If your parents were shrinking violets, the odds are increased that you will be too. But that's far from the whole story

In particular, if they were overly protective, they might have undermined your chances of becoming a future leader. Colloquially, this parenting approach is known as 'helicopter parenting' in reference to the idea of hovering nearby whether needed or not.

Your parents likely had good intentions, such as ensuring you didn't face uncomfortable challenges. Unfortunately, this might have had some inadvertent, unhelpful effects, including "making you less confident and less capable of facing difficulties, therefore [leading you to] exhibit poorer leadership skills", says Dr Judith Locke, a clinical psychologist in private practice and visiting fellow at Queensland University of Technology. Locke's research has involved surveying parenting professionals, including psychol-

ogists and school counsellors, to establish exactly what they mean by helicopter parenting or overparenting.

Her findings suggest this is an approach characterised by a mixture of three factors: being extremely responsive to the child, being extremely undemanding in some contexts, yet being highly demanding in others. For instance, a helicopter parent is likely to be overprotective, overly attentive and believe their child is always right. They will try to do everything for their child (rather than expecting the child to handle it themselves), and might expect their child's peers and school to bend over backwards to accommodate their child's needs too. At the same time, this kind of parent will be highly demanding, in the sense of having high expectations for their child's achievements, overscheduling their child's time and wanting their child to be their friend and in constant contact.

Supervised into submission

The latest research on how this extreme coddling can stifle leadership skills comes from China. Psychologists surveyed nearly 1,500 teenagers – average age 14 – at 13 schools in Beijing. Yufang Bian at Beijing Normal University and her colleagues assessed the teenagers' leadership potential comprehensively. First, they quizzed the teenagers' peers, teachers and parents to get a sense of whether they were seen by others as being a good leader. Second, they checked whether the teenagers were actually in any leadership roles, such as being a team leader in a class science group or a president in a student club.

Meanwhile, the teenagers rated how much their parents had been overprotective by agreeing or disagreeing with statements such as 'My parents supervised my every move growing up' and 'My parents often stepped in to solve life problems for me'. The teens also took quizzes measuring their self-esteem and how confident they felt about being a leader.

The more overprotective their parents, the less the teens were perceived as having leadership potential by others, and the less likely they were to actually be in leadership roles

After controlling for the influence of a number of other factors, such as family socioeconomic background and the teenagers'

achievements, Bian and her team found a clear pattern. The more overprotective their parents, the less the teens were perceived as having leadership potential by others, and the less likely they were to actually be in leadership roles. Statistically, this link was explained by the fact that the teens with helicopter parents tended to have lower self-esteem, which

Many readers will have parents still wanting to be highly involved in their lives. Work out a way where you manage your own life more and cease to rely on your parents as much
– Judith Locke



Teens with lower self-esteem might be tempted to rate their parents unfavourably – but the results are consistent with earlier research

in turn was associated with being less confident about being a leader.

Bian and her team said their findings support the idea that too much of a good thing can be harmful: "In the same way that a lack of proper parenting harms a child's development, overparenting, with its restriction of the child's development of autonomy and problem-solving skills, also has a negative impact on psychosocial development." Overparenting may also create this undermining effect because it signals to children that they are not capable of independence and that their parents don't trust them to look after themselves, let alone others.

Overparenting may also create this undermining effect because it signals to children that they are not capable of independence

It is worth mentioning that these new findings should be interpreted with caution because the observational design of the study means it hasn't proved that helicopter

parenting causes a lack of emerging leadership potential. The research relies on teenagers retrospectively recalling their parents' behaviour, and it's possible that teens with lower self-esteem might be tempted to rate their parents unfavourably as a way to explain their

current feelings. However, the results are consistent with a causal interpretation and the researchers build on a wealth of earlier research, which has consistently shown the apparent detrimental effects of having overprotective parents, albeit that these studies have also featured an observational design.

For instance, psychologists at Florida State University surveyed nearly 500 undergraduates and found that those who had helicopter parents also tended to be less confident in their own abilities. A different team at Miami University quizzed hundreds of undergraduates and found similar results. Those who described having helicopter parents also tended to have more emotional problems, struggled with making decisions and performed worse in their exams.

Your future as a leader

If you run a mile from leadership opportunities and recognise the description of having helicopter parents, you don't have to accept that you'll never be a leader or exhibit qualities of one. First, remember your parents' approach was likely well intentioned, and you won't benefit from feeling resentful. You're in control now and, with dedication and effort, it's possible to shape your own traits and attitudes at any time of life.

Locke, who is also the author of *The Bonsai Child* (a parenting book to help parents develop their child's potential by not

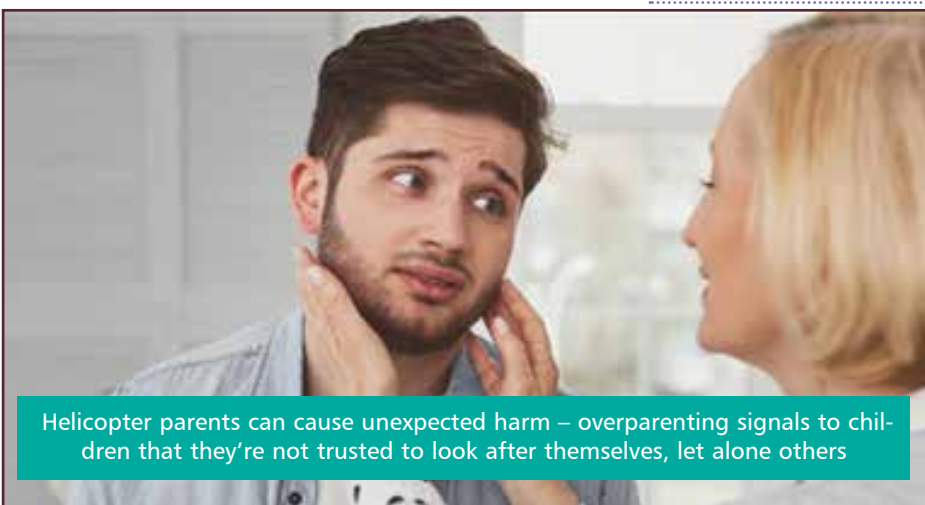

Helicopter parents can cause unexpected harm – overparenting signals to children that they're not trusted to look after themselves, let alone others

Los Abrigos
www.studio4decor.net
Info@studio4decor.net
922 749 793 / 626 955 725

Studio 4 Decor

MONDAY – FRIDAY,
9.30AM – 1.30PM,
AND 3.00PM – 6.00PM
SATURDAY BY APPOINTMENT

STUDIO4DECOR IN LOS ABRIGOS IS EXPANDING!



So many people have walked into the Studio4Decor showroom and thought "WOW! I would love my home to look like this!" and Michael has now decided to expand his business to include a much larger premises just across the road. The new, additional space will specialise in interior furniture and the existing premises will have a fabulous range of terrace furniture for which you can have cushions made in the fabric of your choice. The new premises will be opening shortly but clients can have a sneak preview as they are still operating from the original shop. So watch this space for the official Opening Date!

Michael is the only English-trained upholsterer in Tenerife, and has been in the soft furnishings business for more

than 20 years. He reports that his move to Los Abrigos, where access and parking is excellent, has been his best one to date! His lovely shop on the main street displays some really beautiful soft furnishings, lights, sofas, ornaments, pictures, mirrors and fabrics - all very affordable and you will be very pleasantly surprised by his prices.

Whatever you would like to do with the "look" of your home, Studio4Decor really is the place to head for – even a simple thing like a stunning new picture can transform a room, or perhaps a new light, or mirror. Or, you might like to have new curtains (Michael has all the latest styles/fashions on display) he has the literally hundreds of samples. You might like to add a matching throw for your bed or a custom-built

headboard, or even some gorgeous scatter cushions, anything is possible.

There are many sofas and sofa beds on display, a number of which are hand-made in the work shop adjoining the original premises. Again, you won't find things to be out of your price range – for example, you could have a sofa built to your own specifications from around €800. The huge bonus is that your sofa can be made to fit the space you want it to! You can also have chairs and footstools to match. There is also a wonderful variety of lovely dining room sets soon to be on display in the new shop.

There's absolutely no obligation involved in popping in for a chat or giving Michael a ring, and, of course, contact from estate agents is also always very welcome.



STUDIO4DECOR IS OPEN MONDAY TO FRIDAY, 9.30AM TO 1.30PM AND 3PM TO 6PM, THEREAFTER BY APPOINTMENT, INCLUDING SATURDAYS. AS YOU DRIVE INTO LOS ABRIGOS, YOU WILL FIND STUDIO4DECOR A FEW YARDS DOWN FROM THE START ON THE RIGHT AS YOU ENTER THE VILLAGE - WITH PLENTY OF PARKING NEARBY.

STUDIO4DECOR offers a unique, one-on-one service aimed at taking the stress out of furnishing your property. From single items such as lamps, mirrors, curtains, pictures or ornaments to complement your new decor, we can help.

- ✓ Full re-upholstery service available
- ✓ Bespoke sofas, headboards and pelmets
- ✓ Beautiful made-to-measure curtains
- ✓ 1,000's of fabric swatches to choose from

Call into our Los Abrigos Showroom (29 Calle La Marina, Edificio Bogavante) and let us help turn your ideas into reality.

Beautiful interiors at a price you can afford!

Cont. from page 44

overparenting), recommends beginning to take more control over your own life, including being more financially independent if you can, and avoiding the temptation to call your parents each time you have a problem.

“Many readers will have parents still wanting to be highly involved in their lives. Work out a way where you manage your own life more and cease to rely on your parents as much,” she says. Of

course, these changes on their own won’t transform you into a leader, but they will help you to see yourself as independent and to be more comfortable making autonomous decisions, which will serve you well if and when leadership opportunities arise in your career.

You can also make changes at work, including trying to be more open to criticism, and being proactive in seeking feedback. “My work shows that those who have been overprotected have often

been overpraised as a matter of course, and don’t cope as well with constructive criticism,” says Locke. “For you to improve you need to be open to suggestions of what you need to do to progress.”

It won’t happen overnight, but through practising being more independent and taking the time and effort to build your emotional and decision-making skills, you will find that you can slowly build your confidence – and even start to see yourself as a potential boss.



Some surveys found those with helicopter parents were less confident in their abilities and struggled with decision-making and exams

Much of Your Daily Life Depends on Discoveries Made by Astronomers

By Eric Betz

Why is astronomy important? Astronomical discoveries and inventions have shaped the human experience for thousands of years.

From the earliest days of civilization, astronomy has had an outsized impact on our culture. Ancient humans gave names to the constellations and tracked them so they knew when to plant their crops. Astrologers kept a careful watch on the sky for any change that might foretell doom. And to the average person, the heavens served as a storybook, recording favourite legends like the blockbuster films of the day.

Astronomy’s contributions to society have only grown more important in the thousands of years since then. The digital camera in your DSLR and smartphone — the devices fuelling the rise of social media — likely wouldn’t be what they are today without decades spent by astronomers pushing their limits. Wi-fi was invented by an astronomer trying to sharpen images from his telescope. Even our ideas about the future of Earth

were shaped by astronomers’ observations of the runaway global greenhouse effect on Venus — and what it meant for climate change on our own planet.

Here are four surprising ways astronomers have reshaped our modern world. So, the next time someone asks what studying space is good for, you’ll have a snappy response.

The Star Charts That Direct Modern Life

For more than two decades, an astronomical observatory shaped like a 1,400-foot Y has sprawled across Anderson Mesa in northern Arizona. This instrument, owned by the military and run by astronomers at both the U.S. Naval Observatory and Lowell Observatory, is the biggest telescope of its kind.

The Navy Precision Optical Interferometer uses an array of telescopes to catalog the exact locations of stars and track their minute movements with incredible accuracy. GPS satellites and other space-



The Navy Precision Optical Interferometer in Arizona tracks the motions of stars, guiding the GPS satellites that make much of modern life possible.

craft depend on these star charts to plot their course through the cosmos. Without these data, GPS satellites couldn’t tell us where we are or where we’re going. Equipment used by NASA, the Department of Defence and all manner of other modern tech would be lost, as would your cell phone — and, quite likely, you.

Unlocking the Power of the Sun

In many places across the world, astronomy keeps the lights on. In the 1930s, German-American astronomer Hans Bethe showed that nuclear reactions are what power our sun and all other stars. His work described how the sun uses nuclear fusion to turn hydrogen into helium, releasing huge amounts of energy.

With war on the horizon across Europe, the applications beyond astronomy quickly became obvious. During the Manhattan Project, Bethe was even appointed to lead the theoretical group at Los Alamos, where he worked on the first nuclear bombs. (He later spoke out against the weapons.) Bethe’s work also helped scientists develop nuclear power, which is achieved through fission instead of fusion. There are now hundreds of nuclear power plants around the world.

The Development of Radar

Around the time Bethe was unravelling the secrets of our sun, researchers around the world were developing and deploying the first radar instruments to

study Earth’s ionosphere. This region is where incoming solar and cosmic radiation ionize our planet’s atmosphere, knocking away electrons from the atoms there. As Britain grew increasingly concerned about German air raids, the country’s defence department asked radio physicist Robert Watson-Watt about employing the technology as a kind of death ray to down enemy planes. Instead, the scientist suggested radar could be used to track approaching aircraft; as World War II erupted, radar technology became pivotal on land, in the air and at sea. Radar’s uses now extend far beyond the military. Without it, forecasters wouldn’t be able to watch approaching weather and spot regions of concern, such

as forming tornadoes.

The Invention of Memory Foam

As mattress companies like to remind us, the average human will spend about one-third of their life asleep. If you’re regularly getting a good night’s sleep, you might need to thank NASA. During the Apollo program, Charles Yost, an engineer at North American Aviation Inc., was tapped to work on absorption technology for the command module that carried astronauts to the moon.

Then, just a few years later, NASA enlisted that experience again. This time, he was assigned to help build safer, more comfortable airline seats for airplanes flown by NASA’s Ames Research Centre. According to NASA, “Yost created an open-cell, polymeric ‘memory’ foam material with unusual viscoelastic properties; that is, it possessed both high-energy absorption and soft characteristics.” The new foam offered more protection if there was a plane crash — and it was also more comfortable on long flights. They called it “slow spring-back foam.” Yost spun the tech off into the private sector, where upgraded versions are still used in everything from football helmets to motorcycle seats to clothing and, yes, mattresses.



EUROMUEBLE

www.euromueble.es

**MORE THAN 2.000 DIFFERENT!!
ITEMS FOR IMMEDIATE DELIVERY**

27 DIFFERENT!! MATTRESSES SIZE FOR IMMEDIATE DELIVERY

TRANSPORT FREE ASSEMBLY

~~399€~~
279€
3 Seater Sofa with Chaislongue

~~29€~~
29€
Chair

~~253€~~
179€
Mattress

TRANSPORT FREE ASSEMBLY

90x190 135x190 150x190
179€ 249€ 279€

~~199€~~
139€
Side Board 120x76x40
*KIT

TRANSPORT FREE ASSEMBLY

~~399€~~
219€
Bed Sofa

~~339€~~
235€
Wardrobe 152x200x46
*KIT

PAY YOUR SHOPPING IN 24 MONTHS INTEREST FREE

~~299€~~
199€
Fridgefreezer

213L

~~1499€~~
999€
Full Kitchen

INCLUDES 5 HOME APPLIANCES
FRIDGEFREEZER - RANGE HOODS - OVEN - COOK TOP - SINK

~~399€~~
229€
Three-Seat Sofa with table



OPEN MONDAY TO SATURDAY FROM 09:00AM TO 20:00PM



WE SPEAK SPANISH, ENGLISH, FRENCH, GERMAN, ITALIAN AND PORTUGUESE

THE LARGEST CHAIN OF FURNITURE STORES IN THE CANARY ISLAND - 12 STORES

Oceans could return to a picture of health in just one generation

By Christian Cotroneo

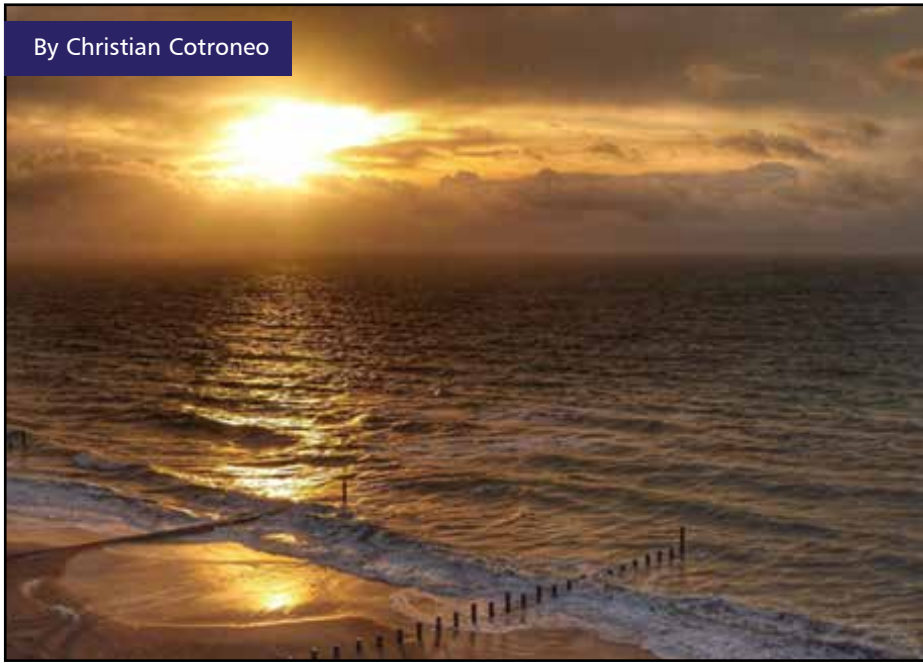

Our oceans face a number of threats, but if we act soon and act in concert, we can keep them healthy for future generations. Try to imagine the future as a tale of two oceans. There's the story we're only too familiar with — how rising sea levels, plastic-addled marine life and overfishing are turning the seas into graveyards. And then there's the fresh narrative offered by a major new scientific review: humpback whales off the coast of

Australia, elephant seals reappearing in the U.S. and Japan's green turtles swimming back onto the scene. In short, we could see an ocean renaissance — and it could happen in just one generation. "We have a narrow window of opportunity to deliver a healthy ocean to our grandchildren, and we have the knowledge and tools to do so," Carlos Duarte, the professor at King Abdullah University of Science and Technology in Saudi Arabia who led the

review, tells The Guardian. "Failing to embrace this challenge, and in so doing condemning our grandchildren to a broken ocean unable to support good livelihoods is not an option."

The report, published this week in the journal Nature, suggests oceans may be a lot more resilient than we think. And if we take decisive action now, they could be in a healthy, life-sustaining state again by 2050.

But urgency is key.

The oceans, scientists argue, need us to undo the damage we've caused, starting now. Otherwise, future generations will only know the tragic tale of the "other" ocean. That's the one that sees water temperatures continue to rise, pollution and acidity levels choke marine life — and coastlines, along with the communities that live near them, overwhelmed. Currently, as scientists warned in a previous study, sea levels are rising faster than

they have in at least the last 3,000 years.

"We are at a point where we can choose between a legacy of a resilient and vibrant ocean or an irreversibly disrupted ocean," Duarte notes in a statement. Sure, some of those changes needed will take a grand, global effort. Governments need to get on the same page for major issues. Vast stretches of ocean need international coordination to protect. The same goes for reining in pollution. Not to mention the bane of all sea life — out-of-control industrial fishing operations that turn oceans into biological deserts.

And none of that, the review authors note, will come cheaply. The cost to bring oceans back from the brink could run as high as \$20 billion — and that, they estimate, would only protect about 50 percent of the waters. Still, considering how many human lives and economies rely on the ocean, the investment would be repaid 10-fold. Besides, plenty of signs suggest even small efforts are making a major impact on ocean health. Developing mangroves and salt marshes along coasts, the review notes, has already noticeably reduced the amount of carbon diox-

ide that slips into the sea. Such developments also provide some protection for communities against rising sea levels.

What's more, the review notes, the fishing industry is slowly becoming more sustainable. Destruction of crucial habitats for marine life — seagrass and mangroves — has almost stopped completely or been restored. The researchers also point out that since the commercial hunting of humpback whales ended in the Southwest Atlantic, their population has surged from the brink of extinction to around 40,000 today.

"Overfishing and climate change are tightening their grip, but there is hope in the science of restoration," Callum Roberts, a professor at the University of York who served on the review's international team, tells The Guardian. "One of the overarching messages of the review is, if you stop killing sea life and protect it, then it does come back. We can turn the oceans around and we know it makes sense economically, for human well-being and, of course, for the environment."

Humboldt penguins face threats from ocean acidification and overfishing. Other marine creatures face similar obstacles

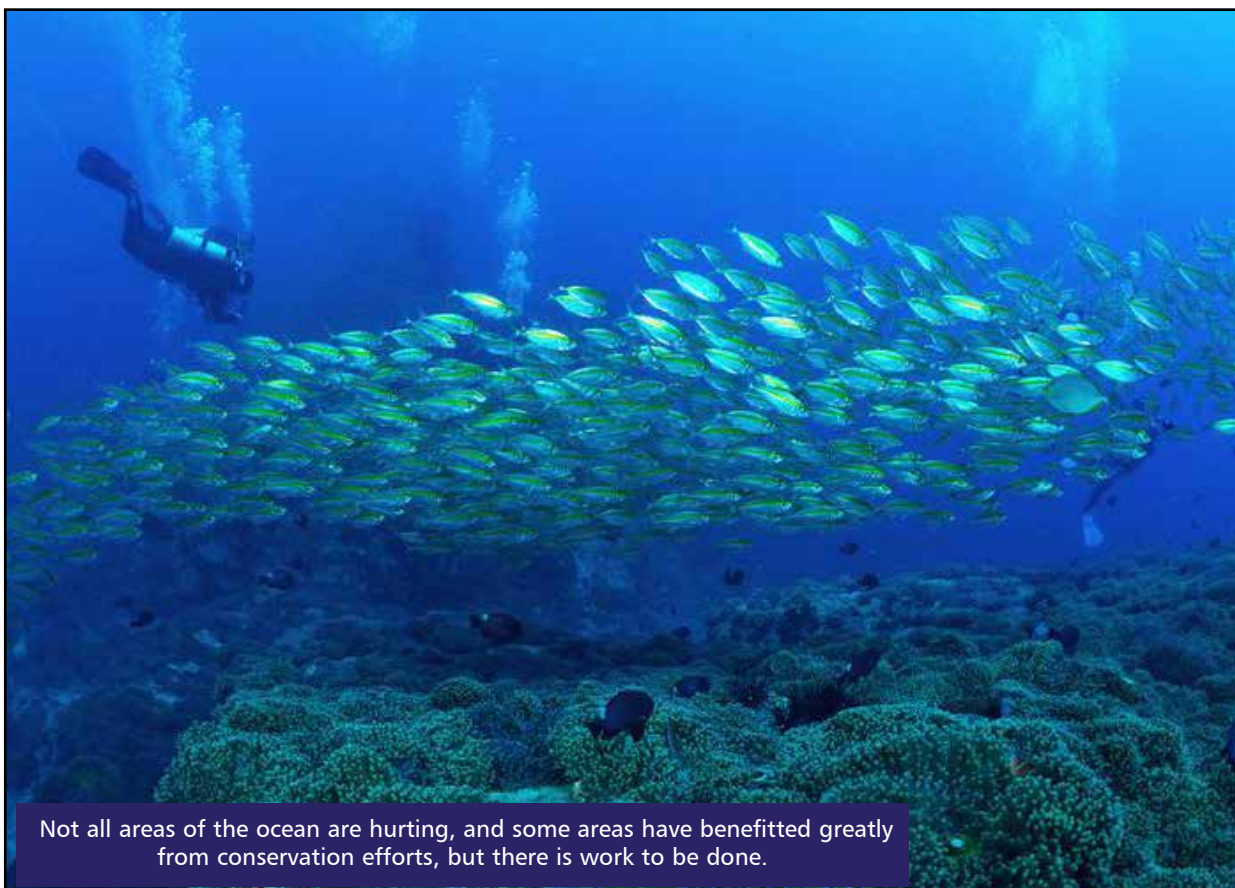

Not all areas of the ocean are hurting, and some areas have benefitted greatly from conservation efforts, but there is work to be done.



EL PATIO

GARDEN FURNITURE



WE ALSO SUPPLY FURNITURE FOR BARS & RESTAURANTS!



**SITUATED DIRECTLY BEHIND THE BINGO HALL
IN LAS CHAFIRAS**

C/ Argentina, 7, LAS CHAFIRAS INDUSTRIAL ESTATE (San Miguel de Abona)

+34 922 736 203

info@patiosur.com • www.patiosur.com

**Hot Spring Spas
Titanium Heat Pumps
Pool Covers and Rollers
Saunas**



**Designed by BMW Group
Design Works USA.**



Waves have a structure, with parts, like this:

Aqualux Pools and Spas
Calle Daniel Feo Feo, Nave 5, Las Chafiras, Tenerife
Tel: 922 736 944 / Mob: 619 781 924
www.aqualuxspas.eu
Email: aqualuxtenerife@gmail.com

Tree rings tell a story of water and climate change

By Natalie Parletta, freelance science writer based in Adelaide and an adjunct senior research fellow with the University of South Australia.

By unlocking the secrets of tree rings, scientists have created a global database of trees' water-use efficiency, which they hope will help improve rainfall predictions and management of the world's water resources. The study, published in the journal *Nature Climate Change*, reveals that trees are not acclimatising well to increasing carbon dioxide concentrations – a discovery that lead researcher Mark Adams, from the Swinburne University of

Technology, Australia, says is “truly surprising”. Numerous high-profile papers have reported that water-use efficiency increases with rising carbon dioxide levels, and this had become widely accepted as fact. But the new study, the first to collate global data on the stable carbon isotope composition of tree rings, turns that notion on its head. Tree-ring carbon isotopes are directly related to trees' water-use efficiency and are therefore vital for understanding past cli-

mates and predicting future climates across the globe, Adams explains. Tropical latitudes, which span sections of North and South America, Africa, Asia and Australia, are important regulators of climate, especially rainfall, from evaporation or transpiration of plants. Plants' ability to control water loss to the atmosphere also impacts how much remains in the soil and is available for run-off – although their water-use efficiency varies.

The storybook of trees

In a previous study on leaf transpiration, Adams' team discovered that leguminous trees such as acacias (*Acacia* spp.), which produce seeds in pods, use water more efficiently than non-legumes. N subsequent research with tree-rings, they found that rainfall played a major role in driving

water use efficiency in tropical forests – drier forests were acclimatising to climbing carbon dioxide concentrations much faster than wetter forests, with important implications for climate modelling. “This striking result really required us to look further as the modellers who predict climate and weather, and those who predict run-off and streamflow, now routinely include water-use efficiency as part of their models,” Adams says. “In fact, their models are much less accurate without knowledge of plant-controlled transpiration flux of water to the atmosphere.”

By analysing 422 records of tree-ring isotopes stretching back more than 150 years, his team has now found that water-use efficiency increased most in the years following the Great Depression and World War II – periods with



much slower increases in carbon dioxide levels.

This has dropped considerably since then, Adams says. “Since WWII, the rate of increase in water-use efficiency has been slowing, virtually without pause, so that by the first decade of the present century, [it] was hardly increasing at all.”

They also found that trees respond differently to increased carbon dioxide concentrations:

flowering trees (angiosperms) have slowed their response much more than non-flowering trees (gymnosperms), coming to a virtual halt. This might change with the current coronavirus pandemic.

“If there is a pause in carbon dioxide emissions as a result of reduced economic activity generally,” says Adams, “then we may see a rebound in the rate of change in water-use efficiency.”

Archaeology bombshell: How historians unearthed ‘Spanish Stonehenge’ in breakthrough find

By Charlie Bradley, Express News UK Reporter

ARCHAEOLOGISTS and historians have been fascinated by the mysteries of Stonehenge - and they were just as excited when one man claimed to have found Spain's equivalent. The Dolmen of Guadalperal, also known as the treasure of Guadalperal and as the Spanish Stonehenge – was

discovered in 1926, during a research and excavation campaign led by the German archaeologist Hugo Obermaier between 1925 and 1927. Historians have tried to decipher exactly why and how it came to existence. It has been stated that it could be a solar temple – and has also been used as a burial enclave.

There have also been a wealth of Roman artefacts and remains found at the site located in Eastern Spain. These included a coin, ceramic fragments and a grinding stone – indicating that at that time it was safely preserved from looting. Eleven axes, ceramics, flint knives and a copper punch were found in a nearby dump.

A settlement was also discovered, dating to the time of construction, which presumably housed the builders. Obermaier discovered houses, charcoal and ash stains, pottery, mills, and stones to sharpen axes.

In 1963, construction of the Valdecanas reservoir inundated the monu-

ment; it is only visible when the water is low, but drought conditions in the last decade have exposed the monument in several summers. However, this has also caused damage to the find. The structure was seen fully for the first time in 50 years in July 2019, when a NASA satellite photograph during a drought revealed its 150 stones.

The Dolem de Guadalperal consists of about 100 monolithic stones, some reaching as tall as six feet, and is 7,000 years old. Local resident Angel Castano told the Local last year: “Like Stonehenge, [the megaliths] formed a sun temple and burial ground. They seemed to have a religious but also economic purpose, being at one of the few points of the river where it was possible to cross, so it was a sort of trading hub.”

The original Stonehenge in Wiltshire is set within earthworks in the middle of the most dense complex of Neolithic and Bronze Age monuments in England.

Archaeology news: Stonehenge is located in Wiltshire



Historians estimate that the cluster of rocks was constructed at any time from 3000 BC to 2000 BC. It is one of the most famous landmarks in the UK and has become a symbol of British culture and history. Since 1882 it has been labelled a legally protected Scheduled Ancient Monument, and was also

added to UNESCO'S list of World Heritage Sites in 1986. Stonehenge could have been a burial ground from its earliest beginnings. Deposits containing human bone date from as early as 3000 BC, when the ditch and bank were first dug, and continued for at least another 500 years.



Archaeology news: The monument was revealed by drought



Archaeology news: Stonehenge is an icon of British culture

500sqm
DISPLAY AREA!



Calle Tilena, 19, LAS CHAFIRAS



922 749 664

649 574 851

OPENING HOURS

Monday – Friday:
9.00am – 5.00pm

Saturday:
10.00am – 2.00pm

- ✓ Second Hand Store
- ✓ Household Clearances
- ✓ We Buy Your Furniture and Pay **CASH!**
- ✓ Delivery/Collection Island-wide

Email: losabrigosauctionroom@hotmail.com
Web: second-hand-tenerife.com



WE HAVE NEW STOCK ARRIVING EVERY DAY!



Magic Moments

Your One Stop Party Shop

IS MOVING!

We Are Relocating

The Shop To

CC San Eugenio

(Mercadona Shopping Centre)

Ground Level

We will be closing here

Friday 6th March at 6pm

The Plan is to re-open

Saturday 14th March.

Watch This Space!

Adeje Farmers Market

**Calle Archajara
Adeje**



Saturday/Sunday: 8.00am – 2.00pm

Wednesday: 3.00pm – 7.00pm

Your requests! Our Solutions! Without Surprises!

ADVERTISING AND MARKETING IN TENERIFE

Tenerife Surprise is THE website to get to know the island, whether you want to come for a holiday, or move here permanently, Tenerife Surprise researches, describes and promotes the best professionals on the island to provide solutions for ALL your requests!



Tenerife Surprise is a marketing and advertising company, working online, providing services for any type of businesses in Tenerife. We are ready to help you anytime!



Calle Londres, Local LF-19,
FANABE, 38679, Adeje, Tenerife



f Tenerife Surprise
Instagram tenerifesurprise



642 796 365/88

www.tenerifesurprise.com ✉ tenerifesurprise1@gmail.com

MARRERO HOME



KITCHENS

Why should you come to Marrero Home?

- 1** We are specialists in KITCHEN DESIGN AND MANUFACTURE!
- 2** We offer the BEST PRICES!
- 3** We deliver your new kitchen the fastest!
- 4** We have a huge range of kitchens IN STOCK!
- 5** Our team of professionals is here to help you design your new kitchen!

WARDROBES

FLOORING

SOFAS AND
SOFABEDS

FURNITURE



922 703 117



Avda. Claudio Delgado Diaz, 103 - Las Chafiras - San Miguel de Abona - TENERIFE



maderasmarrero@maderasmarrero.com



www.maderasmarrero.com

The Tenerife Property and Business Guide
 Editor and Publisher:
 Ali JS Gray NIE: X-5323899-C
 trading as Spanish Property Guides
 C/ Luciano Bello Alfonso No 5,
 LAS CHAFIRAS, San Miguel de Abona, 38639

General Enquiries:
 Tel: 922-703725
 E: george.thetpg@gmail.com
 W: thetenerifepropertyguide.com

Office Hours:
 Monday – Friday:
 9.00am – 5.00pm

The Tenerife Property and Business Guide takes all reasonable care to check the contents of every advertisement or article, but cannot accept responsibility for the claims or statements made in them. Also, statements or opinions expressed by contributors do not necessarily reflect those of the Editor or Publisher. Material featured in The Tenerife Property and Business Guide may not be reproduced without the express permission of the Editor. ©2018 The Tenerife Property and Business Guide.

Printed by: Artes Graficas del Atlantico, Gran Canaria

ENERGY PERFORMANCE CERTIFICATES IN SPAIN

APRIL 2020 UPDATE

The total number of Energy Performance Certificates carried out in the Canaries since June 2013 now stands at 235,511, with some 1,237 being registered up until 16th March, when the online platform for registration of Certificates was suspended due to the 'State of Alert' put in place throughout Spain in response to the recent COVID-19 outbreak. With this 'Alert' in place until at least Thursday 9th

April it is likely that no more certificates will be able to be registered until after that date. In reality, at this point in time with architects, surveyors and engineers being told to stay at home in all but extraordinary situations there will be little data collected to be used to register any certificates. And as for the recovery of this and the performance of the property market when constraints are

lifted it's anyone's guess. The above figure as usual groups both residential and commercial properties and those for sale as well as for rent in all of the Islands which together form the Canaries.

For those of you who are not aware of Energy Performance Certificates (EPCs), they were introduced in Spain and its dependencies by Royal Decree on 5th April 2013. This Law requires that,

from 1st June 2013, an EPC must be obtained by the owner whenever a domestic or commercial property is Built, Sold or Rented.

Selling your property

From 1st June 2013 property owners are required by law to present an Energy Performance Certificate when a property is placed on the market and prior to any advertising. When the property is sold, the Notary will need to see the EPC, termed the Certificado de Eficiencia Energética in Spain.

Renting your property

Either you or your agent, must obtain an EPC. An agent will not be legally allowed to offer or advertise your property for long term letting without one. Where a property has already been let prior to 1st June 2013, no EPC is required until one tenant leaves and the

property is offered for long term rental again. If your property was built after 2007 you should already have an EPC provided by the seller. If you only rent your property out on a short term basis, for less than 4 months of each year, you may not need to have an EPC. If you are the tenant your landlord or the letting agent should be able to show you the EPC for your property.

The EPC contains:

Information about a

property ranging from 'A' (most efficient) to 'G' (least efficient). The Certificate, registered with the Canarian Government is valid for 10 years.

How to arrange an EPC:

If you are selling or renting out property, you will need to engage an Accredited Assessor, who will visit your property to inspect and then produce and register your properties Energy Performance Certificate.



property's energy use and typical energy costs, and recommendations as to how you may be able to reduce energy use and save money.

An EPC allocates an Energy Efficiency Rating,

If you have any questions, or wish to arrange for me, Philip Wright, to carry out your energy Performance Certificate please call me on 667 757 323.

May 2020

DOG OF THE MONTH

Tabo



This beautiful dog is called Tabo. He is 5 years old and has been waiting for so long to be adopted. He has a lovely nature and really deserves a chance in a loving home. Can YOU find it in your heart to provide Tabo with his 'for ever home'? *The Centro de Protección Animal de Tierra Blanca is located off Junction 15 of the TF-1 by the restaurant Los Chasneros, just 200 metres above the TF-1. They don't ask for adoption fees, only a donation of food and some photos to let them know how your new pet is getting on in his/her new home. Please call Rachel on 629 031 273 for more information.*



Opening Hours:
 Mon-Fri:
 10am - 2pm
 Av. Virgen de Guadalupe, 21
 38679 -
 LA CALETA
 Costa Adeje

Art Gallery LA MUSA
 Paintings, sculptures and inclusive art projects for private homes, hotels and resorts.
 Call us any other time to make an appointment:

 **667 608 083**
618 888 897

www.lamusadeadeje.com

MY THAI LOUNGE

Puerto Colon Marina, San Eugenio

- * COCKTAILS
- * FRESH JUICES
- * THAI FOOD
- * QUALITY WINES
- * SELECTION OF BEERS



Come and enjoy the authentic Thai cuisine of the lovely, recently-opened *My Thai Lounge*, overlooking the beautiful Puerto Colon Marina.

This modern and family-friendly Thai Restaurant was created because of the spectacular views available from its first-floor location and spacious terrace overlooking the harbour.



How would you like to enjoy a romantic dinner with a glass of wine while watching the sun go down over the marina – or a night of fun with your whole family – allowing the Thai cuisine to surprise and delight your senses!

Whatever you are looking for, you will find it the *My Thai Lounge* with its wonderful ambience and the fabulous views the cherry on top!

 MYTHAILOUNGE KATRIEN

 (+34) 670 883 604

LOCAL 223, C.C. PUERTO COLON
38670 - ADEJE - TENERIFE

Closed on
Wednesdays

Sebastian & St. James

International Financial Advisers Limited

Speak to us about:

Investment Bonds
Regular Savings Plans
Pensions • Life Assurance
Overseas Pension Transfers (QROPS)
Pension Income Drawdown
International Health Cover

Sebastian & St James have specialist advisers in all aspects of financial advice for clients in Europe and the UK

Advice based on
integrity, trust & experience.

info@ss-ifa.com

+34 667 513 689 (Local Consultant)

+353 (1) 2343171 (International Head Office, Dublin)

+44 (0) 1446 704420 (UK Administration Centre)

www.ss-ifa.com

Registered with the FCA no. 582504

Sebastian & St James International Financial Advisers Limited is regulated by the Central Bank of Ireland

Money in the Bank or Money in a Bond?

Make an informed choice!

The majority of us keep money in a bank account. Why? Because it is easy, relatively secure, and easily accessible. There is also a Deposit Protection Scheme in place which covers the amount in your bank account up to €100,000 or £75,000. So far, so good?

The Deposit Protection amount has been reduced from £85,000 which was the previous compensation limit. This means that if a bank or building society cannot meet its obligations and subsequently fails, or becomes insolvent, the maximum compensation you will receive will be £75,000 or £150,000 for a joint account (husband and wife).

What about growth on your savings?

Returns are not good, interest rates are hardly inflation-beating and your hard-earned cash is not really being put to work for you. In fact, the average savings account is paying less than 1% per year and some have even reduced to 0.2% or even 0.1%!

So how does this look in reality? Consider this: £20,000 in an average savings account with a gross interest rate of 1% will pay: £20,000 at 1% pa, equalling £200 each year before tax.

What is the alternative? - A Spanish Tax Compliant Bond

Setting up a Spanish tax compliant bond is no more difficult than setting up a bank account, and, once you have invested, you have easy access to your money: regular, or one-off withdrawals, to suit your needs.

which is subject to a strict legal and regulatory environment, to European Law, all applicable European directives and regulations and to meet European solvency margins. Under EU law, assets are to be used to repay policyholders should the company be wound up.

The returns over the last few years have been:

2012	2013	2014	2015	2016
8.0%	7.6%	7.5%	10.3%	5.8%

The growth on a Spanish Tax Compliant Bond is **free of tax** until a withdrawal is made -even then only the **growth** is subject to tax.

The growth on a Spanish Tax Compliant Bond is free of tax until a withdrawal is made -even then only the growth is subject to tax.

Any tax due is paid directly to the Hacienda and no Modelo 720 declaration is required for holders of this kind of Bond. The Bond can also be held jointly so there should be no liability to Succession Tax on the first death.

Any tax due is paid directly to the Hacienda and no Modelo 720 declaration is required for holders of this kind of Bond. The Bond can also be held jointly so there should be no liability to Succession Tax on the first death.

The Bond is backed by an AA-rated financial institution

The Bond is backed by an AA-rated financial institution which is subject to a strict legal and regulatory environment, to European Law, all applicable European directives and regulations and to meet European solvency margins. Under EU law, assets are to be used to repay policyholders should the company be wound up.

*Sebastian & St James International Financial Advisers Limited:
advice based on integrity, trust and experience.*

Avda Londres 1, Sur y Sol, Local 1
Los Cristianos, Arona 38650

Office: 922 797 438 / 922 751 587
Mobile: (00 34) 673 778 700

www.tenerifeislandrentals.com
info@tenerifeislandrentals.com



Tenerife Island Rentals & Buy Tenerife

Property Management

- ✓ Specialists in Long Term Rentals in south Tenerife
- ✓ With more than 17 years' experience, we are ideally placed to look after your property!
- ✓ We take care of every aspect and our experienced office and maintenance team are here to give you complete peace of mind.

Rent with Confidence

- ✓ Tenant satisfaction brings regular rental income
- ✓ Property checks and transparent maintenance work
- ✓ Central Admin Office in Los Cristianos
- ✓ Hands-on team offering a genuine, professional service



**Come and talk to the experts - Call 922 797 438
or Email: info@tenerifeislandrentals.com**

**URGENTLY REQUIRED - ALL TYPES OF PROPERTY!
PROFESSIONAL CLIENTS WAITING!**

Long Term Rentals

OVER €2,000 p/m Puerto Colon, Duplex

€2,500
2 bed · Long-term rental Very nice and fully furnished duplex in the residential complex "Club Atlantis Bungalows", which is located on the seafront, with the beach and the port of Puerto Colon in front. This is a very well maintained complex with three swimming pools (two of them heated), a restaurant and a solarium with a bar next to the pool. Comprising three b... For full information see website or contact:
Ref: VR5674D | Vym
Canarias | 922 787 210

Playa Paraiso, Apartment

€2,000
2 bed · Long term luxury apartment for rent in the new complex "Ocean Garden", Playa Paraiso. Two bedrooms, two bathrooms, an open-plan kitchen with a living room and a terrace overlooking the pool. The apartment is fully furnished with high quality furniture, the kitchen is equipped with all the necessary appliances, there are fitted wardrobes, air conditioning ... For full information see website or contact:
Ref: VR5386D | Vym
Canarias | 922 787 210

€1,999 - €1,000 p/m El Madronal, Townhouse

€1,750
3 bed · A lovely house in the El Madronal area, South Tenerife.

Comprising a large living room with kitchen, three bedrooms, three bathrooms, two terraces and a garage. Living area of 160 m2. The house is sold fully equipped and furnished. Inside of the house is in the excellent condition. The house has an installation of the electricity and water meters. Madroña... For full information see website or contact:
Ref: VR6015DN | Vym
Canarias | 922 787 210

Playa Paraiso, Apartment

€1,500
3 bed · Modern and bright apartment on the seventh floor overlooking the ocean and the island of La Gomera in a residential complex Ocean Garden. The apartment is furnished and equipped with everything necessary. It includes 3 bedrooms, 2 bathrooms, an open-plan kitchen, a large living room and a terrace. Also included in the price is a place for a car in the unde... For full information see website or contact:
Ref: VR5491D | Vym
Canarias | 922 787 210

La Orotava, Villa

€1,400
4 bed · This beautiful detached villa is located in a very peaceful area of Northern Tenerife. From here, both the historical city center of La Orotava and the touristic center of Puerto de la Cruz can be reached in just a

couple of minutes by car. Because of its location, the views over the Atlantic Ocean and the Orotava Valley are amazing. The property has a... For full information see website or contact:
Ref: RR21400V | Agata's Real Estate |

Golf del Sur, Bungalow

€1,300
3 bed · Lovely 2 bed-2 bath bungalow with linked self contained 1 bed apartment, on popular complex with pools, bar restaurant and close to the golf courses and main amenities. The main house has 2 double bedrooms, 2 bathrooms, separate fitted modern kitchen with utility room, large terrace overlooking the communal pool, private parking for 2 cars, all equipped a... For full information see website or contact:
Ref: KV0203 | Tenerife Alizes Properties | 922 738653 / 626 274040

Playa Paraiso, Apartment

€1,300
2 bed · Spacious apartment on the third floor in Ocean Garden complex, Playa Paraiso. Ocean view, 65 m2 interior and a terrace of 13 m2. It has two bedrooms, two bathrooms, an American style kitchen and a large living room. Completely new, fully furnished and decorated. The complex has a community pool. The apartment is located in a touristic area

near restaurant... For full information see website or contact:
Ref: VR6749D | Vym
Canarias | 922 787 210

Sotavento, Apartment

€1,300
3 bed · This brand new furnished apartment is situated in one of the seacoast complexes of Sotavento, near El Medano. It comprises of 3 double bedrooms with built-in wardrobes, 2 bathrooms (main ensuite), living room with balcony, separate fitted kitchen, utility room. Includes a parking space and a storage room in underground safe garage. On site facilities: poo... For full information see website or contact:
Ref: KV0231 | Tenerife Alizes Properties | 922 738653 / 626 274040

Los Cristianos, Apartment

€1,200
1 bed · For rent apartment in a nice residential complex "Parque Tropical", Los Cristianos. Total of 73 m2. Including 1 bedroom, living room with terrace, kitchen fully equipped. Complex with garden and two swimming pools (one of them is for children). Within walking distance of the beach, supermarkets!
Ref: VR6053D | Vym
Canarias | 922 787 210

Amarilla Golf, Apartment

€1,200

3 bed · Tastefully furnished, spacious three bed apartment in secure complex with a garden to the front and a large garden to the rear with entertainment space and hot tub.
Ref: 2077 | Homes & Away | 922 737 044

Golf del Sur, Apartment

€1,100
1 bed · Large fourth floor, one bed apartment with sea views on prestigious complex. Available for a minimum of six months.
Ref: 1749 | Homes & Away | 922 737 044

Golf del Sur,

€1,050
3 bed · *Available now* Three bed, two bath apartment on popular international bowling complex.
Ref: 1447 | Homes & Away | 922 737 044

Callao Salvaje, Townhouse

€1,050
2 bed · Townhouse in complex San Francisco, Callao Salvaje. It offers two bedrooms, two bathrooms, kitchen and living room with opens to a large private terrace. There is an own garage with direct access to the house. The util area is 92m2 plus 24m2 terrace. The complex has a communal swimming pool and is situated in a walking distance from the beach Playa de Aja... For full information see website or contact:

Ref: VR6680D | Vym
Canarias | 922 787 210

Playa Paraiso, Apartment

€1,000
2 bed · Beautiful apartment in the newly built Ocean Garden building. The complex has communal swimming pools and green areas. The 80m2 apartment is distributed in 2 bedrooms, 2 bathrooms, living room, kitchen, terrace. With views of La Gomera. € 1000 per month with water and electricity separately.
Ref: VR3959D | Vym
Canarias | 922 787 210

€999 - €650 p/m El Medano, Apartment

€980
2 bed · Situado en Las Tejitas en Sotavento complejo 2 y consta de dos dormitorios, dos cuartos de baño, salón con zona comedor y cocina americana totalmente equipada con todos los electrodomésticos estándar (nevera, congelador, placa gobernador, horno, Microondas, Cafetera gobernador, Hervidor de agua, tostadora, etc), sala técnica con Lavadora, caldera para agu... For full information see website or contact:
Ref: VR6654D | Vym
Canarias | 922 787 210

Golf del Sur, Penthouse

€950
3 bed · *Available from 27th February* Nicely furnished 3

bed, 3 bath penthouse with two terraces and sea view. Parking space included. Water and electricity on top.

Ref: 1252 | Homes & Away | 922 737 044

Los Cristianos, Apartment
€950

1 bed · We offer for rent an apartment in the complex "Port Royale", Los Cristianos. The apartment is located on the ground floor with direct access to the pool and consists of one bedroom, bathroom, American-style kitchen with living room and terrace. The price includes monthly expenses for light and water up to 50 euros. Available from 04/01/2020.

Ref: VR6737D | Vym Canarias | 922 787 210

Golf del Sur, Bungalow
€900

2 bed · This beautiful 2 bedroomed duplex bungalow has been completely refurbished to high standards, and it comes completely furnished and equipped. It comprises of 2 double bedrooms, 1 ensuite bathroom, 1 shower room downstairs, 1 shower room upstairs, living room opening to a sunny terrace, built-in design kitchen, and a small terrace upstairs for more private... For full information see website or contact:

Ref: KV0230 | Tenerife Alizes Properties | 922 738653 / 626 274040

Los Cristianos, Apartment
€875

2 bed · Attractive, fully furnished and equipped 2 bedroom apartment for long term rent in quiet location (close to all amenities) with sea and mountain views. The property enjoys satellite TV, internet and there is a Community pool. Bills extra. Would suit mature couple. Contact Anne on 629 606 494.

Ref: AMH-001 | A M Howells | 629 606 494

Los Cristianos, Apartment
€850

1 bed · Very large one bedroom ground floor garden apartment. Large double bedroom, living room with American style kitchen and large bathroom with separate shower cubicle and bath. Beautiful terrace and garden with automatic watering system. The rental price does not include bills. No pets allowed.

Ref: AP0531 | Tenerife Island Rentals and Buy Tenerife | Sales: 922 751072 / Rentals: 922 797438

Golf del Sur, Apartment
€850

2 bed · *Available from 1st June to end of Sept*Well-appointed, converted two bedroom apartment with a mezzanine level which has two single beds. West facing terrace with stunning sea views. Wi-Fi included. Water and electricity on top.

Ref: 2075 | Homes & Away | 922 737 044

Golf del Sur, Apartment
€850

1 bed · *Available from April*Well-present, one bed, one bath apartment with fabulous views over the golf course, out to sea and over to Montaña Roja. Wi-Fi included.

Ref: 2084 | Homes & Away | 922 737 044

El Medano, Apartment
€850

2 bed · New and modern apartment on the seafront. In front of La Tejita Beach, Vista Roja residential complex, this

apartment with 2 bedrooms, 1 bathroom, living room, terrace, kitchen and parking space.

Ref: VR3945D | Vym Canarias | 922 787 210

Amarilla Golf,
€850

FRINA Tenerife
business & property agent

+34 670 636 004 · +34 617 294 803

Calle Colón, 1st Floor, local 213, Puerto Colón, 38660 Adeje

tenerifebusinessforsale.com · tenerife-property.com

English, Spanish, Dutch, Flemish, German, French, Danish

visit us here

2 bed · Well-appointed, two bed duplex apartment on residential complex with heated pool.

Ref: 1986 | Homes & Away | 922 737 044

Amarilla Golf,
€850

2 bed · Beautiful property, recently refurbished, ideal for retired couples. Sea and mountain views, in walking distance from bars and restaurants. Just a 10 mins walk to Marina San Miguel. Pool in complex. Definitely worth a view!

Ref: 2062 | Rentals in Tenerife | 606 284883

Golf del Sur, Apartment
€800

1 bed · Nicely presented, one bed apartment with good sea and marina views. Sold with garage space and trastero.

Ref: 1976 | Homes & Away | 922 737 044

Golf del Sur, Apartment
€800

1 bed · Nicely furnished one bed apartment close to all amenities. Good sea and Marina views. Water and electricity on top. Underground garage space included.

Ref: 2074 | Homes & Away | 922 737 044

San Miguel, Apartment
€800

3 bed · Nicely refurbished ground floor apt. with a beautiful garden, BBQ in heart of San Miguel Town. Large storage room. Pets allowed. Bills excluded. Close to shops and transport, 15 min drive to nearest beach and only a 20 min drive to the south airport.

Ref: LAPR1075 | Los Abrigos Properties | 922 170021

Amarilla Golf, Apartment
€775

1 bed · Beautifully appointed, spacious one bed garden apartment with two terraces in quiet location, near the Golf course. Wi-Fi access included. Water and electricity bills included up to 50€ per month.

Ref: 2083 | Homes & Away | 922 737 044

Golf del Sur,
€775

1 bed · *Available until 15th December*Modern, refurbished, ground floor, one bedroom

Currencies Direct

Call Donna in our Los Cristianos office
+34-922 971 781 or Carol on +34-687 906 607

apartment on a popular complex. Fabulous sea views. Water and electricity bills not included.

Ref: 1877 | Homes & Away | 922 737 044

Los Abrigos, Apartment

FRINA Tenerife
business & property agent

+34 670 636 004 · +34 617 294 803

Calle Colón, 1st Floor, local 213, Puerto Colón, 38660 Adeje

tenerifebusinessforsale.com · tenerife-property.com

English, Spanish, Dutch, Flemish, German, French, Danish

visit us here

2 bed · Lovely 2 bed ground floor apartment on seafront with fantastic views. Balcony, 2 bathrooms, american kitchen. Sat tv dish on shared roof terrace, lift in building. Garage and storeroom. Bills exclusive. Small pets allowed.

Ref: LARP539 | Los Abrigos Properties | 922 170021

Los Cristianos, Apartment
€750

2 bed · AVAILABLE TO RENT FROM 22 April 2020 FOR SIX MONTHS ONLY. Two bed apartment located on the first floor to this complex, you have stairs leading up to the front door of the property, inside you have an American style fully fitted kitchen, both bedrooms are double size, balcony from the lounge area which has sea views overlooking the pool area and you have ... For full information see website or contact:

Ref: AP0351 | Tenerife Island Rentals and Buy Tenerife | Sales: 922 751072 / Rentals: 922 797438

Golf del Sur, Apartment
€750

1 bed · Well-appointed, top floor, one bed apartment with terrace giving afternoon sun. WiFi included. Water and electricity bills on top.

Ref: 1988 | Homes & Away | 922 737 044

San Eugenio Bajo,
€750

1 bed · One bedroom apartment available until October 2019. Large double bedroom, living room with American style kitchen, bathroom and balcony. Community pool. Close to shops and restaurants.

Ref: AP0246 | Tenerife Island Rentals and Buy Tenerife | Sales: 922 751072 / Rentals: 922 797438

Las Rosas, Linked House
€720

2 bed · Two bedroom townhouse available for long term rental. On the lower floor there is a large living room, separate kitchen diner and WC, on the upper floor there are two bedrooms, one with terrace area and a family bathroom. Large garden area behind secure gates. The property is

being rented unfurnished. Pet friendly property. Water and electricity are not i... For full information see website or contact:

Ref: ADO0467 | Tenerife Island Rentals and Buy Tenerife | Sales: 922 751072 / Rentals: 922 797438

Los Abrigos, Apartment
€700

2 bed · Lovely 2 bed 1 bath, American Kitchen, on 2 ND floor, lift in building, sea views from 2 balconies, close to shops transport schools, beach 5 mins and Airport south 15 mins available end Jan 20

Ref: LAPR1069 | Los Abrigos Properties | 922 170021

Costa del Silencio,
€700

2 bed · Lovely two bed, one bath apartment on well-maintained complex.

Ref: 1744 | Homes & Away | 922 737 044

Amarilla Golf, Apartment
€675

1 bed · Nicely presented, top floor apartment with sunny terrace on popular complex.

Ref: 2065 | Homes & Away | 922 737 044

Golf del Sur,
€660

1 bed · This 1 bed, 1 bathroom apartment is on the beautiful complex of Aguamarina. Close to the sea, marina, bars, shops and restaurants. Fully furnished to a very nice standard. Ideal for a retired couple. Lift and pool in building. No pets allowed.

Ref: 1080 | Rentals in Tenerife | 606 284883

Golf del Sur,
€660

1 bed · Perfect for a retired

couple, fully furnished and with a large outside terrace. Quiet complex with 2 pools. Beautiful sea view. Very close to San Blas Commercial Centre and bus stop.

Ref: 1086 | Rentals in Tenerife | 606 284883

Costa del Silencio,
€650

1 bed · Top floor, fully furnished 1 bedroom, 1 bathroom apartment with lounge and American style fitted kitchen which leads off to a large terrace with its own stairs up to the private roof terrace. There is also a private parking space available and community swimming pools. Nice quiet residential complex.

Ref: 01 1168 | Tenerife Prime Property | 922 703 725

Los Abrigos,
€650

3 bed · * Available from end of July until October* First floor 3 bedrooms apartment in a popular local village with stunning sea views. Water and electricity bills on top.

Ref: 1712 | Homes & Away | 922 737 044

San Eugenio Bajo, Studio
€650

Beautiful studio in the Island Village Heights complex in San Eugenio. Fully equipped Bills included up to 50€ per month Very well located Available from June 1.

Ref: VR5973D | Vym Canarias | 922 787 210

Under €650 p/m
Puerto de Santiago,
€570

1 bed · Ground floor one bed apartment on the sea front to Puerto Santiago, within walking distance to all shops and local

amenities. The apartment has a double size bedroom, American style fitted kitchen and large terrace area with stunning sea views.

Ref: AP0182 | Tenerife Island Rentals and Buy Tenerife | Sales: 922 751072 / Rentals: 922 797438

Los Abrigos,
€500

Bright spacious 1 bedroom apartment, in the centre of Los Abrigos, close to main amenities and only a few minutes walk to the port and the sea. Living with American kitchen, 1 double bedroom, 1 bathroom, internal patio, equipped and furnished. First floor, no lift. Bills extra. Pets not allowed.

Ref: KV0224 | Tenerife Alizes Properties | 922 738653 / 626 274040

Puerto de La Cruz, Apartment
€500

We offer a studio located in the center of the city of Puerto de la Cruz, in the Martinez area. It is a furnished studio that has 39 m2 and has a room, bathroom and balcony. Water and electricity expenses are included. 1 month deposit and 1 month commission We are a boutique international real estate agency. Our team is speaking English, German, Russian, P... For full information see website or contact:

Ref: IR500S | Agata's Real Estate |

Los Cristianos, Garage
€500

Garage/Storage in Los Cristianos. Total of 130 M2 with Office and Bathroom. Rent € 500, + Monthly Expenses.

Ref: VR5811D | Vym Canarias | 922 787 210



VACANT PROPERTY CHECKS / KEYHOLDING

Due to an increase in people asking for **Vacant Property Checks** over the last six months, and our help in averting major property problems recently, we would like to offer this Service at a **Discounted Rate**.

Whether you are away for a week, or for several months, this Service - offering the best value and our personal attention - may be of interest to you.

What does having this Service mean for you? It means that, simply, wherever you are, you will have peace of mind!

Professional Weekly
Property Checks:

For more information, please call
our office today:
Tel: 922 797 438 / 673 778 700
Email: info@tenerifeislandrentals.com



Tenerife Island Rentals
& Buy Tenerife

Tenerife Prime Property

Tel: 922 703 725 / 627 230 360

Email: carolhale.tpp@gmail.com

Web: www.tenerifeprimeproperty.com

LOS CRISTIANOS, SPORTS BAR/RESTAURANT



Traspaso available on this very popular, long-established (2008), fully licensed Sports bar/restaurant in great location surrounded by Holiday and Residential complexes in Los Cristianos. The owner, who set the business up in 2008, has decided to take a break from this busy life. Opening hours: 4.00 p.m. - 2.00 a.m. Monday - Thursday and 9.00 a.m. - 2.00 a.m. Friday - Sunday. The business operates with a team of 4, generating an annual turnover of around €550.000 on a 5-year renewable lease (renewed Feb 2020), monthly gross rent €2,650. Local is 123sqm interior (60 covers) and 35sterrace (40 covers). Live entertainment every night with top acts. Full food menu available daily.

Ref: B-117

Price: €150,000

SAN EUGENIO ALTO, BAR/RESTAURANT



An excellent opportunity to take over the Traspaso on this popular established Restaurant in an excellent location. Successfully trading for many years as a family business with repeat customers and over 50 5* reviews on Trip Adviser, fully licenced. The sale price includes fixtures and fittings. Currently run by 1 person with opening hours of 2-11pm 5 days per week there is an excellent opportunity for a couple, and to expand the business further. Healthy accounts available on request.

Ref: B-116

Price: €75,000

LAS GALLETAS, BAR/CAFE



Highly popular, profitable and fully legal sea-front bar/cafe in the attractive and vibrant seaside fishing village of Las Galletas This ready-to-walk-in-and-take-over business can accommodate up to 40 persons inside space and outside. The cafe operates excellent working hours (approx 9.00am - 5.00pm daily, 6 days per week) and has a highly loyal customer base (English, Dutch, Belgian, French, Italian, Spanish etc) both residential and holiday-makers from nearby Costa del Silencio and Ten Bel. The owners, who have built the business from scratch have decided to retire. Accounts available.

Ref: B-111

Price: €75,000

LOS ABRIGOS, VETS & GROOMING PARLOUR



Lovely, modern, fully equipped and alarmed Vet's on the main street in Los Abrigos. Has an Office and Reception area, Treatment area and Grooming parlour (Monthly rent just €450) was refitted at a cost of €25.000 in 2019. The replacement cost of all equipment would currently be in excess of €60.000. Opening Hours 10.0am - 2.00pm and 4.00 - 8.00pm, Saturdays 10.00am-1.30pm. Current contract expires in 2021 but will be renewed.

Ref: B-118

Price: €120,000

Business Section

OVER €350,000

Tenerife South, Manufacturing business

€4,000,000

Are you looking for a sound investment in the Canary Islands? We are excited to offer you the opportunity to invest in a highly reputable and well-established manufacturing company, which occupies an unrivaled position of being a world leader in its industry! The company, which has been successfully established since 25 years, is specialized in the in... For full information see website or contact:
Ref: 1545 | FRINA Tenerife SL - Business Sales | 922 085 191

Guaza, Apartment Block

€1,500,000

If you want to invest in this building, give it a face-lift, dedicate it to rentals, or re-sell this is the building for you, the options are endless. This building will revenue a high profit and a rapid return on your investment. The building itself is in perfect condition, it has been built in the beautiful "Canarian" style with elegant cornices, it has... For full information see website or contact:
Ref: GB3-G1X5 | RD Properties | 922 732 862

Cabo Blanco, Hotel

€890,000

6 bed · Location: Central, Touristic area, Close to amenities, Close to restaurants/bars/cafes, Close to shops, Exclusive development, Quiet location. Views: La gomera, Sea. Additional: Development possibilities, Viewing recommended. Rooms: American style kitchen, Bathroom, Hall/entrance, Lounge and dining area. Quality: Good condition, Tastefully decorated, Furn... For full information see website or contact:
Ref: 407-HT6 | Island Estates | 922 790 767

San Eugenio Alto,

€630,000

Large freehold for sale, located in a complex in San Eugenio Alto. The local used to be a supermarket but is empty today and would need refurbishment before it can reopen as another business or supermarket. Details: The premises are spacious 585m2 plus terrace of 50m2 and a basement of 50m2.
Ref: 2293 | FRINA Tenerife SL - Business Sales | 922 085 191

Golf del Sur, Empty Local

€577,000

In need of TLC, large commercial property with separate apartment above the premises.
Ref: 1948 | Homes & Away | 922 737 044

El Galeon,

€367,500

♦ Location: Central, Close to amenities ♦ Additional: Investment opportunity, Development possibilities ♦.
Ref: C3074 | Hofman Estates | 922 777 747

Las Chafiras, Fully Equipped

Local

€350,000

Additional: Viewing recommended. Rooms: Store rooms, Bar, Bathroom. Quality: Tastefully decorated, Traditional features, Bright, Well presented, Furnished, Good condition, Spacious. Features: Many special features. Outside: Large terrace. Parking: Parking nearby, Parking available.
Ref: 464-C | Island Estates | 922 790 767

€349,999 - €250,000

Las Americas,

€336,000

A busy restaurant and pizzeria for sale freehold. The interior measures 74m2 and exterior is 50m2 with a seating capacity of 60. It has 4 full time staff and has the opening hours of 3pm to 11pm.
Ref: E100 | Tenerife Properties | 630 372702

Las Americas,

€325,000

Freehold of a bar for sale with a kitchen. 40m2 storage room and 2 toilets. Seats 40 and has air-conditioning and all project/paperwork.
Ref: E289 | Tenerife Properties | 630 372702

Palm Mar,

€297,163

- Well finished properties, with exceptional building materials and modern fittings.- Private garages and parking space are available in the complex. Also lots of parking space outside the complex.- Easy access, almost all on one level, with big passage ways which lead to each property, and to the lovely pool surrounded by plants and flowers.- Lovely poo... For full information see website or contact:
Ref: NPL01 | 2nd Home Tenerife |

Las Americas, Empty Local

€285,000

♦ Location: Touristic Area, Close to the Harbour, Close to the coast, Close to the beach, Close to amenities, Central ♦ Close to: Transport, Shops, Harbour, Coast, Beach ♦ Features: Air conditioning, Adapted for wheelchairs ♦.
Ref: 0C3276 | Hofman Estates | 922 777 747

Torviscas Bajo, Supermarket

€275,000

FRINA Tenerife offers for sale this busy supermarket in Torviscas Bajo. It has been running for 2 years and has a good reputation. The customer profile is both tourists and locals. The location secures a lot of footfall and there is not a lot of direct competition in the area. The supermarket is spacious 100m2 and well-equipped.
Ref: 2320 | FRINA Tenerife SL - Business Sales | 922 085 191

Los Cristianos,

€271,000

Local for sale freehold with bathroom, air conditioning, blinds, alarm, safe, furnished and including telephone lines. The property has large windows and natural light.
Ref: E089 | Tenerife

Properties | 630 372702

Puerto de Santiago, Car Leasing/Rental Business

€267,000

New on the market is this Car Rental for sale in Puerto Santiago, which is sold as a leasehold or a freehold. Furthermore, the business sells Tenerife excursions and the office has an ATM, which both provide to the healthy income. Premises of the Business for SaleYou find the main office centrally in Puerto Santiago and a fully equipped workshop close by... For full information see website or contact:
Ref: 2233 | FRINA Tenerife SL - Business Sales | 922 085 191

Playa Paraiso, Fully Equipped Local

€250,000

If you are looking for a well-established and easy-to-run business, you cannot miss this store for sale in a busy complex of Playa Paraiso. This store sells everyday products like snacks, drinks and sun lotion but also toys and quality suitcases and bags of brands like Valentino and Guess. The business shows a healthy income and especially the profit on b... For full information see website or contact:
Ref: 2237 | FRINA Tenerife SL - Business Sales | 922 085 191

€249,999 - €150,000

Playa San Juan, Bar/Cafe

€225,000

This Traspaso Cafeteria for sale is located in Playa San Juan where it opened a year ago. It is known for an international menu offering brunch, burgers, Spanish specialties and a large variety of homemade bread and pastry. Moreover, it is popular due to its lovely location on the seafont. Premises of the Traspaso Cafeteria for Sale The inside pre... For full information see website or contact:
Ref: 2298 | FRINA Tenerife SL - Business Sales | 922 085 191

San Eugenio Bajo,

€200,000

Leasehold for a cafe/bar with 26 tables and current opening hours of 10am-10pm.
Ref: E251 | Tenerife Properties | 630 372702

Golf del Sur, Bistro

€199,950

Freehold cafe/bistro available with captive market in exclusive holiday complex. All fixtures and fittings included.
Ref: 2051 | Homes & Away | 922 737 044

Icod de Los Vinos,

€190,000

Shop Premises for sale with an internal area of 150m2, empty shop unit in the spanish village of Icod, built in two levels, great location just off the main street. It has toilets and an interior patio. Very good condition. Easy access.
Ref: COM552 | The Property Gallery | 922 719925 / 922 719889

Las Galletas, Excursion Business

€190,000

FRINA Tenerife offers this well-established water excursion for sale that is known for all-inclusive whales & dolphins experiences. Besides for whale watching the trips include open bar, refreshments, swimming, snorkeling, and a great atmosphere. The boat is fully licensed for tourist and whale excursions and have the yellow (blue) flag too. Furthermore, ... For full information see website or contact:
Ref: 2246 | FRINA Tenerife SL - Business Sales | 922 085 191

Costa Adeje,

€185,000

We are pleased to offer this great opportunity to own not only local but also a prospective business! Local of 135m2 distributed over two floors and with a private terrace in front. There is a possibility to buy only the local or local together with the equipment and all licences. Contact us for more details!
Ref: VS5780D | Vym Canarias | 922 787 210

Las Americas, Bar/Cafe

€169,000

New on the market is this profitable British Bar for sale, which is located in Las Americas, Tenerife. It has been established for more than 25 years and shows a more than healthy income. The owners only sell to retire after many successful years, so if you are looking for a healthy business with a proven income you cannot miss this. IT is the perfect ... For full information see website or contact:
Ref: 2306 | FRINA Tenerife SL

€157,500

For sale with FRINA Tenerife is this freehold local in Las Americas, which can be turned into a bar, café, shop or office. Today the freehold is empty, and it will need a refurbishment and a license to open. This empty freehold local for sale is 73 m3, has a toilet and electricity installed but needs a refurbishment. The local is located in the center of ... For full information see website or contact:
Ref: 2073 | FRINA Tenerife SL - Business Sales | 922 085 191

Tenerife South, Estate Agent

€152,000

For sale with FRINA Tenerife is this Real Estate Business established for more than 20 years in the south of Tenerife and registered as an SL. If you dream of entering the property market of Tenerife this is a safe way to a strong position. Today the business is run by the owners and 2 employees. Included In The Estate Business For Sale Besides from, a st... For full information see website or contact:
Ref: 2112 | FRINA Tenerife SL - Business Sales | 922 085 191

Las Americas,

€150,000

Centro Commercial, Terranova. Playa de las Americas. 48 m2 Local with 90 m2 Terrace all ready set up for a BAR, fully equipped and ready to open. Option of a FREEHOLD also for 240.000 a LEASEHOLD IS 16.000a 5 YEARS RENEWABLE. 1.200 a PER MONTH RENT.
Ref: COM483 | The Property Gallery | 922 719925 / 922 719889

San Eugenio Bajo,

€150,000

Freehold - A travel agents for sale in a busy shopping area. The rent is 1,800 euros per month and the sale includes the computers and office equipment. 45,000 Euros for the leasehold.
Ref: E237 | Tenerife Properties | 630 372702

Tijoco Bajo, Empty Local

€150,000

A spacious freehold local in a brand new building. Parking space included in the subteranean garage, the main room is 76.85m2 with another interconnecting room of 72m2 (store room) Terrace of 10m2 with sea views.
Ref: 7337 | Clear Blue Skies SL | 922 714 772

€149,999 - €100,000

San Eugenio Bajo,

€147,500

Popular Entertainment Bar for sale in the busy area of San Eugenio.
Ref: E261 | Tenerife Properties | 630 372702

Golf del Sur,

€140,000

INVESTOR ALERT! A fantastic unique opportunity to acquire 2 fabulous commercial properties in an extremely well maintained development in Golf Del Sur that offers a mixture of holiday

makers and residents and with an extremely busy bar/ restaurant in close proximity, there is also a certain amount of "foot traffic" for you to be able to tap into, for whate... For full information see website or contact:
Ref: GOLF01440 | Tenerife Property Shop | 922 714700 / UK: 0871 871 6131

Costa Adeje, Bar/Cafe

€140,000

This leasehold café in Adeje serves a large variety of international homemade dishes and pastry, which makes it popular for breakfast, lunch, dinner and take away. It is located centrally in Adeje town and the clients are both residents and tourists. Today the owner does not work here, hence this is a great business to buy whether you want an investmen... For full information see website or contact:
Ref: 2299 | FRINA Tenerife SL - Business Sales | 922 085 191

Golf del Sur, Excursion Business

€139,000

FRINA offers for sale this Tenerife Jetski Business, which is located in Gold del Sur. Golf del Sur is a great location for a jetski business since you have plenty of tourists year-round however, you have less competition and much lower rent than in the bigger harbours in Tenerife South. The business includes 6 new Jetski of the brands Seadoo, Yamaha and ... For full information see website or contact:
Ref: 2307 | FRINA Tenerife SL - Business Sales | 922 085 191

Callao Salvaje, Restaurant

€135,000

FRINA Tenerife offers for sale this lovely restaurant in Callao Salvaje. It is in a good location, the terrace even offers sea view. The restaurant has a good reputation and many returning customers, it has been established for 3 years. The menu is international food and the customer profile is mainly tourist.
Ref: 2321 | FRINA Tenerife SL - Business Sales | 922 085 191

Puerto Colon, Charter Yacht

€129,500

These 3 charter boats for sale rent out to tourists for private charters. Each of the boats can be rented from 1 to 6 hours, depending on the clients wish. Moreover, the boats can be rented with or without a private captain. This is a fairly easy business to run since many clients prefer going out on their own. The Charter Boats for Sale There are ... For full information see website or contact:
Ref: 2220 | FRINA Tenerife SL - Business Sales | 922 085 191

Costa del Silencio,

€125,000

1 bed · Beautiful 1 bedroom apartment with 2 terraces of 7.20 sqm facing West. The apartment is in excellent condition, fully furnished and located in a very nice aparthotel

FRINA Tenerife

business & property agent

+34 670 636 004 · +34 617 294 803

Calle Colón, 1st Floor, local 213, Puerto Colón, 38660 Adeje

tenerifebusinessforsale.com · tenerife-property.com

English, Spanish, Dutch, Flemish, German, French, Danish

visit us here

- Business Sales | 922 085 191

Las Americas,

€159,000

Warehouse: Large with cellar, three offices, two toilets, one new large freezer room, 12m2 cold storage, linear shelves, furniture, fully equipped to start the activity. Local rent 1.700 per month (been established for 10 years).
Ref: Com536 | The Property Gallery | 922 719925 / 922 719889

Las Americas,

The Tenerife Property & Business Guide

Tel: +34 609 714 276

george.thetpg@gmail.com
www.thetenerifepropertyguide.com



ADVERTISE WITH US AND BUILD YOUR BUSINESS!

with heated pool, only 5 minutes walk from bars, shops and restaurants. There's a bus stop nearby.

Ref: 1448-1218 | Tenerifehome.com | 922 783066

Puerto Colon, Restaurant

€125,000

New on the market is this Puerto Colon traspaso restaurant for sale with FRINA Tenerife. It is located on the ground floor of Puerto Colon commercial centre which secures plenty of footfall and harbour view. Moreover, the rent is more than fair for this size local and in this location! Premises of the Puerto Colon Traspaso Restaurant The premises are spacious. For full information see website or contact:

Ref: 2279 | FRINA Tenerife SL - Business Sales | 922 085 191

Playa Paraiso, Supermarket

€125,000

If you are looking for a well-established and easy-to-run business, you cannot miss this minimarket store for sale in a busy complex of Playa Paraiso. This store sells everyday products like snacks, drinks and sun lotion but also lots of childrens toys. This store has two departments, one with bags and suitcases, and another with everyday products, snacks... For full information see website or contact:

Ref: 2316 | FRINA Tenerife SL - Business Sales | 922 085 191

Golf del Sur, Restaurant

€120,000

FRINA Tenerife is happy to present this well-established restaurant in Golf del Sur. After 9 years in the same hands, the owners have built a good

reputation and enjoys many returning guests - both residents and tourists. It is known for Spanish tapas and British type food. Premises of the Restaurant in Golf del Sur This restaurant is very spacious ... For full information see website or contact:

Ref: 2221 | FRINA Tenerife SL - Business Sales | 922 085 191

Arona, Commercial Property

€119,000

1 bed · Cozy apartment with 1 bedroom located in Annapurna, a sea front complex with amazing communal pool with sea water and gardens. The residence is located at the entrance of the charming village of Las Galletas. Sold furnished.

Ref: 1376-0418 | Tenerifehome.com | 922 783066

Callao Salvaje, Bakery

€110,000

This well-established French bakery for sale has been open for almost 7 years and is known for homemade and mouth-watering pastries. The high quality of the product and the fact that it is all homemade secures the owner a high profit and a healthy business. Premises of the Bakery for Sale The premises are spacious 240 m2 and is sold with all the bak... For full information see website or contact:

Ref: 2188 | FRINA Tenerife SL - Business Sales | 922 085 191

Costa del Silencio,

€109,000

1 bed · 1 bedroom apartment which has been completely renovated situated in an aparthotel. South - East facing terrace with view on the gardens. The complex offers a communal swimming pool and

parking for residents only (access with remote control).

Ref: 1311-0917 | Tenerifehome.com | 922 783066

Arona, Commercial Property

€109,000

1 bed · This 1 bedroom apartment is located on the 1st floor in Palia don Pedro, an aparthotel with reception, swimming pool (heated in the winter!), animation etc. The apartment has an american style kitchen and is very luminous with direct access to the terrace from the living room. Parking space in the communal parking is included! Community fess: 197€ month, ... For full information see website or contact:

Ref: 08-0819 | Tenerifehome.com | 922 783066

FRINA Tenerife

business & property agent

+34 670 636 004 · +34 617 294 803

Calle Colón, 1ª Floor, local 213, Puerto Colón, 38660 Adeje

tenerifebusinessforsale.com · tenerife-property.com

English, Spanish, Dutch, Flemish, German, French, Danish

€99,999 - €50,000

Costa del Silencio, Bar/Cafe

€89,000

You find this freehold bar for sale in Costa del Silencio, where it has been open for 15 years. The bar is especially popular among British guests, has many regular clients and is especially known for a lovely Sunday Roast and Saturday Night Special. This bar will be a perfect option for a British

couple who wishes to run their own business in Tenerife. P... For full information see website or contact:

Ref: 2162 | FRINA Tenerife SL - Business Sales | 922 085 191

Costa Adeje,

€85,000

We have been instructed to offer for sale this very successful cabaret bar in Callao Salvaje, considered by many as the destination bar for all that is Callao. If you are not afraid of hard work, like a challenge, have excellent customer service skills, creative thinking and enjoy seeing all your efforts rewarded then this already very profitable cabaret ... For full information see website or contact:

Ref: VS5357D | Vym Canarias | 922 787 210

Los Cristianos, Commercial Property

€85,000

Commercial premises in the center of Las Americas. The total area is 66m. The office is located on the first floor of a commercial center City Center. The premise has a lot of natural light, it's ideal for the office, beauty center, dentist. Just 5 minutes walk to the beach and big commercial area.

Ref: VS5855DE | Vym Canarias | 922 787 210

Puerto Colon, Empty Local

€85,000

Large local of 128m2 for sale in Puerto Colon.

Ref: VS3416D | Vym Canarias | 922 787 210

Playa Fanabe, Bar/Cafe

€80,000

♦ Location: Residential Area ♦

Close to: Town ♦ Quality:

Furnished ♦ Features: Air conditioning ♦ Additional:

Investment opportunity ♦.

Ref: 0C3410 | Hofman Estates | 922 777 747

Golf del Sur, Bar/Cafe

€80,000

For sale with FRINA Tenerife is this popular English café in Golf del Sur, which is known to serve English breakfast and traditional home cooked British food. The café has great reviews on both Google and TripAdvisor and the owner has been here for more than 5 years. Premises of the English Café for Sale This cozy café measures 40 m2 inside and has ... For full information see website or contact:

Ref: 2186 | FRINA Tenerife SL - Business Sales | 922 085 191

necessary equipment in the Playa Fanabe area on the 1st line from the beach. Local with kitchen and a bar of 50 m2 equipped with air conditioning. Terrace of about 50 m2 with a capacity of 10/11 tables. Recently refurbished full opening awning. The restaurant also has a ground floor of about 50 m2 with direct access to a pri... For full information see website or contact:

Ref: VS6699D | Vym Canarias | 922 787 210

Fanabe, Bar/Cafe

€68,500

FRINA Tenerife is happy to offer this Sandwich Café in Fanabe, which is part of a popular and well-known franchise. Hence, it is a great success already and easy to run. Also, this particular

Piano Lessons

Learn at your own pace with a relaxed, friendly teacher to guide and support you.

Custom made lessons to suit all levels and musical interests.

I am experienced in preparing students for ABRSM Piano Exams.

Call Louise 686 014 355
www.pianointenerife.eu

KEYBOARDS FOR HIRE

café of the franchise has very good reviews on Tripadvisor and Google. Since 2015 the café has been in this amazing location next to the beach, so it is well-established... For full information see website or contact:

Ref: 2280 | FRINA Tenerife SL - Business Sales | 922 085 191

Los Abrigos, Bar/Cafe

€68,000

This traspaso for sale in Los Abrigos is a very popular bar-café in an excellent location.

The business has been established for years and has many regular clients. And it has been open for 6 years and is a well-established business in a good area, which keeps expanding. Premises of the Traspaso for Sale The bar-café is spacious 130 m2 with a good size ki... For full information see website or contact:

Ref: 2266 | FRINA Tenerife SL - Business Sales | 922 085 191

Santa Cruz de Tenerife, Commercial Property

€67,500

Bar Cafeteria Transfer. It is transferred cafeteria bar with a lot of popularity, the only cocktail bar, grill and tapas in La Palma, fully equipped, including the pepsi-cola tap, sweppes, 7 up. Being well located, centrally located in Santa Cruz de la Palma, on Avenida Maritima, in front of the beach and is fully operational. Inside capacity: 22 people... For full information see website or contact:

Ref: VS6155DN | Vym Canarias | 922 787 210

Torviscas Bajo, Restaurant

€65,000

Busy and well situated restaurant in Torviscas Bajo area, very close to the Torviscas and Fanabe Beach.

Ref: E333 | Tenerife Properties | 630 372702

Puerto Colon,

€60,000

Local/office in Terranova, Puerto Colon. Sold unfurnished. The building has a lift.

Ref: COM509 | The Property Gallery | 922 719925 / 922 719889

Los Abrigos,

€60,000

A busy bar and restaurant for sale in a popular residential resort. The seating capacity is for 70 people and the measurements are, interior 130m2 and exterior 36m2. The rent is 1,440 Euros per month.

Ref: E096 | Tenerife Properties | 630 372702

Las Americas,

€60,000

Lease hold for sale of a bar located in Las Americas near to El Faro.

Ref: E228 | Tenerife Properties | 630 372702

San Eugenio Alto, Sports Bar

€60,000

Sports Bar for Traspaso in San Eugenio Alto.

Ref: E296 | Tenerife Properties | 630 372702

Llano del Camello, Hairdresser's

€60,000

Hairdresser business transfer in the village of Llano del Camello with the hairdresser licence and esthetic. Contract for rent 850 euros renewable every 5 years. Great opportunity, call us for more information!

Ref: VS4454D | Vym Canarias | 922 787 210

Playa San Juan,

€59,000

Leasehold for sale of a bar. 48m2 interior and space for 9 tables outside, currently open 11am till 3 pm, 18.30pm till midnight. The square is currently being refurbished with a project costing 2.3 million euros.

Ref: E312 | Tenerife Properties | 630 372702

Las Americas, Empty Local

€55,000

Commercial premises in the center of Las Americas. The total area is 33m. The place is located on the first floor of the City Center shopping center. Completely renovated, ideal for office, beauty center, hairdresser. Only 5 minutes walk from the "Golden Mile". Expenses not included.

Ref: VS2531 | Vym Canarias | 922 787 210

Golf del Sur, Commercial Property

€53,000

Freehold commercial premises for sale as investment with a gross return of almost 8% annually. The property is located in the golfing paradise of Golf del Sur in the south of Tenerife, just a few minutes' drive from the airport. The premises are situated on the territory of a luxury time-share and private resort with 184 villas, located just in the middle... For full information see website or contact:

Ref: 1726 | FRINA Tenerife SL - Business Sales | 922 085 191

Golf del Sur, Commercial Property

€53,000

Freehold commercial premises for sale as investment with a gross return of almost 8% annually. The property is located in the golfing paradise of Golf del Sur in the south of Tenerife, just a few minutes' drive from the airport. The premises are situated on the territory of a luxury time-share and private resort with 184 villas, located just in the middle... For full information see website or contact:

Ref: 1726 | FRINA Tenerife SL - Business Sales | 922 085 191

Golf del Sur, Commercial Property

€53,000

Freehold commercial premises for sale as an investment in Golf del Sur in the south of Tenerife. This investment brings a fantastic gross return of over

Ref: 1726 | FRINA Tenerife SL - Business Sales | 922 085 191

9% annually! The premises are situated on the territory of a luxury time-share and private resort with 184 villas, located just in the middle of a championship golf course. This freehold locale is rented ... For full information see website or contact:

Ref: 1724 | FRINA Tenerife SL - Business Sales | 922 085 191

San Eugenio Bajo,

€52,500

A fully equipped beauty salon for leasehold. The property is 300m2 and has 4 qualified staff. Included in the sale is all the equipment including sunbeds, massage table, all chairs and mirrors, there are 3 showers, 4 toilets including disabled. It is in an excellent location and is air conditioned.

Ref: E104 | Tenerife Properties | 630 372702

Las Americas,

€50,000

Reduced for a quick sale A night bar for leasehold in the busiest part of town within the strip known as Veronica's. Rent including community charges is 1,400 euros per month. The club has bar, DJ booth and dance floor inside and a large terrace outside with tables and chairs for approx 40 people and a portable bar. Open to reasonable offers.

Ref: E107 | Tenerife Properties | 630 372702

Torviscas Bajo,

€50,000

Leasehold of a bar/cafe with kitchen + sports bar for sale with an interior of 100m2 and terrace of 80m2.

Ref: E292 | Tenerife Properties | 630 372702

Tijoco Bajo, Bar/Cafe

€50,000

FRINA Tenerife offers this new traspaso take away cafe in Torviscas Bajo. This is a great little business for a single person or a couple of friends who wish to run a take away

swimwear store in Los Cristianos Tenerife. Due to good connections, the owner can sell popular bikini and swimwear brands with 50-70% discounts! Naturally, this attracts many clients in Tenerife that benefits from sunshine and blooming tourism year-round. Premises of the Business The shop is 50 m2 with showroom, dres... For full information see website or contact:

Ref: 2035 | FRINA Tenerife SL - Business Sales | 922 085 191

UNDER €50,000

Torviscas Bajo, Bar/Cafe

€49,000

We offer for sale this bar in Tenerife that is located in a large resident and hotel complex, which guarantees many new and returning guests. The current owner is British as many of the clients, but you will meet all types of tourists and the so-called swallows in this location. If you are looking for a small bar, which doesn't require any skills in the k... For full information see website or contact:

Ref: 2211 | FRINA Tenerife SL - Business Sales | 922 085 191

Los Cristianos, Beauty Salon

€44,000

♦ Location: Touristic Area, Residential Area, Popular urbanisation, Close to amenities, Central ♦ Close to: Schools, Shops, Town, Transport, Medical Facilities, Restaurants/Bars/Cafes ♦ Rooms: Kitchenette ♦ Quality: Furnished, Well presented ♦ Features: Air conditioning ♦ Outside: Large Terrace ♦ Parking: Parking nearby ♦ Additional: Investment opportunity... For full information see website or contact:

Ref: 0C3445 | Hofman Estates | 922 777 747

Las Americas, Commercial Property

Facilities, Restaurants/Bars/ Cafes, Shops, Schools, Town, Transport ♦ Outside: Terrace ♦ **Ref: 0CL3441 | Hofman Estates | 922 777 747**

Roque del Conde, Supermarket

€35,000

Business for sale. Supermarket in Roque del Conde. Fully equipped reformed commercial premises with three air conditioners and video surveillance. With a license and all necessary documents. Monthly fee - 1800 euros with taxes. Good location in a residential area. It is also possible to buy this commercial premises. The total area of 133 m2.

Ref: VS6750D | Vym Canarias | 922 787 210

Las Americas, Commercial Property

€31,500

For sale Local in Borinquen complex, Las Americas. Area 28 m2, glass showcases, needs a complete renovation, the exit to the reception.

Ref: VS4774D | Vym Canarias | 922 787 210

Las Americas, Bike/scooter Rental Business

€30,000

FRINA Tenerife offers this bike & scooter rental for sale, which has been established for 3 years and is located in a super busy area of Las Americas. This shop offers rentals of bikes, e-bikes, mobility scooters and, wheelchairs. The clients are both pedestrians passing by and clients who find the offers online. Included in the business for Sale Th... For full information see website or contact:

Ref: 2185 | FRINA Tenerife SL - Business Sales | 922 085 191

Costa del Silencio, Bar/Cafe

€29,500

If you are looking for a modern and cozy cafe-bar for sale in Costa del Silencio you cannot miss this cafe known for delicious food and Belgium beers. This is a great opportunity for a couple who wishes to relocate to Tenerife and work together. Premises of the Cafe-Bar for Sale The premises are newly refurbished, and the buyer does not have to spend extra... For full information see website or contact:

Ref: 2201 | FRINA Tenerife SL - Business Sales | 922 085 191

San Eugenio Bajo, Bar/Cafe

€28,950

♦ Location: Touristic Area, Close to amenities, Central ♦ Views: Pool. **Ref: 0C3411 | Hofman Estates | 922 777 747**

Costa del Silencio, Pet wash

€25,000

The Self Service is open 6 days a week and the Groom Room is open Tuesday to Friday. Our Pet Services are available 7 days a week, 365 days a year.

€44,000

2 bed - A large local in the Pueblo Canario shopping center, Playa Las Americas. 2nd floor. The space consists of two offices and a service bathroom. This shopping center is located next to the beach in Playa Las Americas.

Ref: VS6538D | Vym Canarias | 922 787 210

Adeje Town, Bar/Cafe

€40,000

♦ Location: Central, Close to amenities ♦ Close to: Medical



Call Donna in our Los Cristianos office +34-922 971 781 or Carol on +34-687 906 607

cafe together. Today the menu is Spanish and Italian inspired dishes like pasta, bocadillos and of course coffee, cold drinks, and cocktails. Premises of the Traspaso Take Away Caf... For full information see website or contact:

Ref: 2207 | FRINA Tenerife SL - Business Sales | 922 085 191

Los Cristianos, Swimwear store

€50,000

New on the market is this outlet



NOW ONLINE!
www.laschafirasbookshop.com

LAS CHAFIRAS BOOK SHOP

The Bookshop is located at Calle Luciano Bello Alfonso No 5 in Las Chafiras (behind and above Pit Team Sur and the Golf Shop, and opposite Marrero Homes). Books cost just €3.00 but we offer a 'Buy two get one FREE' system and we buy books we don't have for 50 cents each.

We now have more than 10,000 books to choose from, either in the Shop itself, or via the internet (www.laschafirasbookshop.com), where you can 'browse' our inventory and order - we will be happy to deliver to anyone not able to get in.

Should you come to the shop and no one is in, just call us on either 609 714 276 or 627 230 360 - we're never very far away and will get back as fast as we can - while you have a coffee at one of the many cafes nearby!

Piano Lessons

Learn at your own pace with a relaxed, friendly teacher to guide and support you.

Custom made lessons to suit all levels and musical interests.

I am experienced in preparing students for ABRSM Piano Exams.

Call Louise 686 014 355
www.pianointenerife.eu

KEYBOARDS FOR HIRE

FRINA Tenerife is long-established and offers a lovely sea view from the terrace. The current owner had the business for 9 years and it is known for the good terrace and cozy evenings with live music and karaoke. Location & Premises of the Traspaso pub for Sale The business is located in San Eugenio Bajo and the pub measure... For full information see website or contact:

Ref: 2267 | FRINA Tenerife SL - Business Sales | 922 085 191

Las Americas,

€P.O.A

Commercial premises for rent or for sale. This property is very well suited for a medical or therapeutic center, fitness... It is available to rent or to buy. The local has 135 m2 in total is situated in a very touristic area in Las Americas, on the promenade. Completely renovated, with air conditioning system, divided into various rooms with toilets/show... For full information see website or contact:

Ref: NPL12 | 2nd Home Tenerife |

Good client base. Security system and medicum sized store room at the side of the shop.

Ref: 2080 | Homes & Away | 922 737 044

Costa del Silencio, Commercial Property

€15,750

Restaurant-bar for transfer in Costa del Silencio, Arona. It is located in a tourist area near the sea. It has all the documents, licenses, and certificates, as well as its positive history on Facebook, Tripadvisor, and other public networks. It has capacity for 50 Pax, with an interior area of 81 m2, and a terrace of 40m2. It also has free parking. **Ref: VS6752D | Vym Canarias | 922 787 210**

Las Americas, Empty Local

€2,500

If you are looking to build your own bar-restaurant in a prominent location, you will be hard pushed to find a better offer than this local to lease. The owner will give the new tenant a 5-year rental contract and offer a month rent-free to refurb the premises. Premises of the Local to Lease The premises are spacious 180 m2 and used to be a bar, ... For full information see website or contact:

Ref: 2205 | FRINA Tenerife SL - Business Sales | 922 085 191

Puerto Colon, Pub

€P.O.A

This traspaso pub for sale with



SAFE CLEAN

PART OF G.D.A. GROUP S.L.U. Est 1987

PEST CONTROL
For private villas, apartments, complexes, providing sanidad certificates for Bars & Restaurants
CONTROL DE PLAGAS
Desinsectación, desratización y certificados

CLEANING
Professional upholstery & carpet cleaning, sofas, beds
LIMPIEZA
Limpieza de sofás, alfombras, tapizados etc.

609 066 973 627 114 090

www.safecleantenerife.net e-mail: info@safecleantenerife.net



FRINA Tenerife S.L.

tenerifebusinessforsale.com

ALONE WE CAN DO SO LITTLE
TOGETHER WE CAN DO SO MUCH

Bargain Cocktail Bar



Bargain

This cozy bar serving drinks and shishas is located in a charming area of Playa San Juan, surrounded by resident complexes and shops. The premises has tables for about 40 guests, a bar and a small kitchen.

Ref.: 2329

Price: 16,000€

Pool Bar In Las Americas



This pool bar located in a complex in Las Americas is a great offer. The inside premises are newly renovated with a large bar and an open kitchen. The terrace is about 45 m2 and has tables for 32 guests, but you could easily put more.

Ref.: 2323

From: 45,000€

Boutique In Shopping Center



Reduced

This clothing store is located in a shopping center in Adeje, which is a good location that guarantees plenty of footfall - mainly tourists. The boutique sells women clothes, shoes and bags. The store is 53 m2 including storage.

Ref.: 2322

Price: 20,000€

Front Line Restaurant



This cozy restaurant in Los Abrigos is known for its international dishes and fresh seafood. It serves both locals and tourists. The restaurant has been operating for 10 years but was recently refurbished and in great condition.

Ref.: 2340

Price: 59,500€

Freehold British Pub



New

After 20 years the owners wish to sell their pub located in Playa Paraiso. It is a classic pub that serves traditional British food like Sunday Roasts, fish & chips, and cold beers. The pub is 50 m2 and has a large terrace of 53 m2.

Ref.: 2170

Price: 139,000€

Frontline Bar-Cafe



This bar & cafe is located in Fanabe. It is a modern bar in a busy location that attracts many tourists. The menu is mainly fresh fish dishes. It is a modern cafe and the premises are 50 m2 inside and with a terrace of 40 m2.

Ref.: 2317

Price: 69,000€

Long-established Bar



This well-established and busy bar is located in the heart of Callao Salvaje. It has been open for 5 years and is well-known in the area. The bar is about 50 m2 and fully equipped and furthermore is a terrace of 40 m2.

Ref.: 2331

Price: 35,000€

Profitable & Large Restaurant



This large and modern restaurant in Los Cristianos is fully refurbished. It has been established for several years and is famous for its Scandinavian menu and wine tastings which most guests come back for again and again.

Ref.: 2333

Price: 109,000€

Profitable Supermarket



New

You find this busy supermarket in Golf del Sur where it opened 6 years ago and today it shows a healthy income being open 7 days a week from 8:00 to 23:00 and run by 3 employees. The store is 180 m2 and are fully equipped.

Ref.: 2319

Price: 150,000€

Empty Local In Las Americas



The premises are spacious 180 m2 and used to be a bar, but it will need a full refurbishment before it can reopen. The terrace is 40 m2 and has the most amazing sea view. Perfect if you are looking to build your own bar-restaurant.

Ref.: 2205

Price: 2,500€

Bargain Water Sport Business



Reduced

This is a unique and bargain opportunity to get both a jet bike and a parasailing business in one buy. Established for 10 years and in a prime location of Tenerife South, where it enjoys little competition and plenty of footfall.

Ref.: 2277

Price: 140,000€

Successful Freehold Restaurant



Reduced

This freehold is one of the most successful restaurants in Costa Adeje. Established for more than 15 years and has a loyal following among locals and visitors that book months in advance. It is 150 m2 with a large terrace and fully equipped.

Ref.: 2064

Price: 795,000€

Popular Music Bar



Reduced

This popular and long-established music bar in Callao Salvaje is famous for its acts and large parties. It has the full music license in place and can even be open all night long moreover, the rent is only 700€ monthly.

Ref.: 2130

Price: 85,000€

Palm Mar Beauty Salon



This salon has been established for 3 years and is currently run by 3 employees. The salon is 40 m2 with a separate massage room, it is in great condition and offers all kind of hair and massage treatments. Note: owner is open to offers!

Ref.: 2313

Price: 29,500€

Bargain 24h Minimarket



This supermarket in Las Americas is located on a busy street and sells liquor, tobacco, souvenirs, and refreshments. The premises are fully equipped with shelves, racks, counter, etc. Also, the supermarket has a terrace and a private toilet.

Ref.: 2327

Price: 24,000€

Luxury Boat Charters



This reputable charter business located in busy in Puerto Colon includes a sailing yacht and a motorboat, which both offers 3-hour excursions to see whales and dolphins but also private charters from 2 hours to full days.

Ref.: 2338

Price: 330,000€

Las Americas Entertainment Bar



This well-known bar has been established for more than 25 years and is famous for its entertainment and shows. The bar is 100 m2, has room for 170 guests and can be open until 5 am. It is sold both as a leasehold and as a freehold.

Ref.: 2310

Price: 125,000€

Smaller Bar-Cafe



Reduced

This bar-cafe is located in Fanabe next to resident complexes and offices so it enjoys many local visits daily. It is spacious 70 m2 and has a large terrace as well. Today the bar is open 6 days a week and run by a couple.

Ref.: 2326

Price: 25,000€

Los Cristianos Restaurant

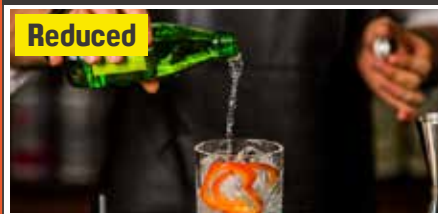

Reduced

This large and modern restaurant has been established for 5 years and is known for delicious food, great cocktails, large shishas and a service that makes many clients return. So, the business shows a healthy income.

Ref.: 2291

Price: 69,000€

Charter Excursion Boat



Reduced

This long-established jet ski excursion is highly ranked on TripAdvisor and known for its new fast machines which give clients the best experiences. And as a buyer you get 8 new jet skis and a new boat in the best location.

Ref.: 2080

Price: 270,000€

+34 670 63 60 04

+34 922 08 51 91

frina@tenerife-business.com

tenerifebusinessforsale.com

we are here too

Calle Colón, 1st Floor, local 213, Puerto Colón, 38660 Adeje

English, Spanish, Flemish, Dutch, German, French, Danish

