

The Tenerife Property & Business Guide

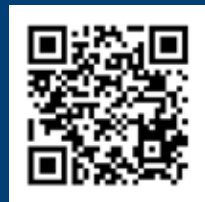

Part of the Spanish Property Guides Group | December 2019 Issue 182

Tel: 922 703 725 • Email: george.thetpg@gmail.com • www.thetenerifepropertyguide.com



LOS CRISTIANOS, SOL Y SUR

CHOOSE FROM TWO LOVELY 1 BEDROOM, 1 BATHROOM GROUND FLOOR APARTMENTS ON THIS SOUGHT AFTER COMPLEX WITH POOL, CLOSE TO THE BEACH AND ALL AMENITIES.

Each property is fully furnished and equipped and has a lounge/dining area, American-style fitted kitchen, and a good-sized, sunny terrace.

Both are priced at €185,000
Quote Ref: AP0510/0511

Please see Pages 2 and 3 for contact details



Tenerife Island Rentals & Buy Tenerife



Everyone at The TPG would like to wish all our advertisers (past and present), contributors and readers a very Merry Christmas and a Happy, Healthy and Prosperous New Year!

Thinking about advertising?

Call The TPG TODAY for the best prices in the south of Tenerife!

609 714 276

POWER ON FM

TENERIFE 89.5, 89.8 & 93.7 FM

BROADCASTING FROM MASCA TO ARICO
WHEN IT'S ON, IT'S ON!

WWW.POWERONFM.COM

COME AND VISIT THE BEAUTIFUL

MY THAI LOUNGE

PUERTO COLON MARINA

See Page 45 for details



SAFE CLEAN

PART OF G.D.A. GROUP S.L.U. Est 1987

PEST CONTROL

For private villas, apartments, complexes, providing sanidad

certificates for Bars & Restaurants

CONTROL DE PLAGAS

Desinsectación, desratización y certificados

www.safecleantenerife.net

CLEANING

Professional upholstery & carpet cleaning, sofas, beds

LIMPIEZA

Limpieza de sofás, alfombras, tapizados etc.

e-mail: info@safecleantenerife.net



Contents: ❄️ ❄️ ❄️ ❄️

- 03-33** Residential Sales
- 34** Monthly Currency update (Currencies Direct)
- 40** Article: *Why stealthy viruses are making you ill*
- 40** Article: *Organic solar cells set 'remarkable' energy record*
- 42** Article: *The manmade 'stars' changing the night sky*
- 46** Article: *Fall of Berlin Wall: How 1989 reshaped the modern world*
- 48** Article: *Could the world cope if GPS stopped working?*
- 52** Is It Better For Your Gut To Eat A Big Breakfast Or A Big Dinner?
- 56-57** Sebastian St James IFAs
- 59** Long Term Rentals
- 61** Businesses for Sale

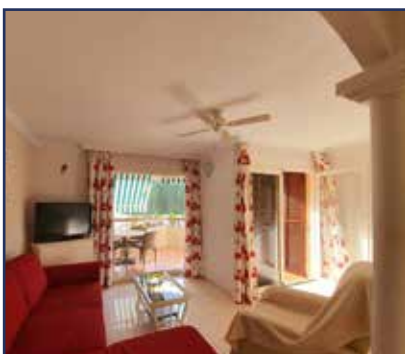

Choose from two lovely 1 bedroom, 1 bathroom ground floor apartments on this sought after complex with pool, close to the beach and all amenities.



❄️ **LOS CRISTIANOS,
SOL Y SUR**

BOTH PRICED AT

❄️ **€185,000** ❄️

REF: AP0510/0511

Call
**922 797 438 /
922 751 587**
❄️ today to
arrange a
viewing! ❄️



Avda Londres 1, Sur y Sol, Local 1
Los Cristianos, Arona 38650

Office: 922 797 438 / 922 751 587
Mobile: (00 34) 673 778 700

www.tenerifeislandrentals.com
info@tenerifeislandrentals.com



Tenerife Island Rentals & Buy Tenerife

Sales

LA CONCEPCIÓN, LLANO DE CAMELLO



- 3 Bedrooms
- 2 Bathrooms
- Separate kitchen
- Large living room
- Good sized balcony
- Adult and children's pool
- Close to all amenities



Ref: AP0258

€155,000

EDIFICIO CRISTINA, SAN MIGUEL



- 3 Bedrooms
- 2 Bathrooms
- Separate kitchen
- Large private roof terrace
- Sea and mountain views
- Close to all amenities



Ref: AP0469

€119,000



LAS AMERICAS, PARQUE SANTIAGO III

Lovely, fully furnished, 1 bed, 2 bath townhouse on sought after, sea front gated community with heated pool, pool bar, restaurant, supermarket and 24 hour security. The property has a lounge/dining area, American-style fitted kitchen and a large, sunny terrace with sea and pool views. Close to the beach and all amenities. Extras include satellite TV. Viewing recommended!



Price: 448,000€

Ref: 1D3425

Built: 48sqm

Terrace: 12sqm

SAN EUGENIO BAJO, OCEAN PARK



Centrally-located, fully furnished, 1 bed, 2 bath duplex apartment in sought after, gated, 'Touristic' complex with pool and communal parking, located close to the sea front and all amenities. The property has a lounge/dining area, fully fitted open plan kitchen and a sunny terrace enjoying lovely sea views.



Price: 239,000€

Ref: 1D3440

Built: 52sqm

Terrace: 15sqm

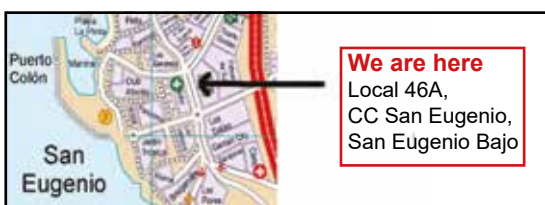

- Bank Repossessions
- Luxury Villas
- Resort and Residential Properties
- Investment Opportunities
- New Developments
- Relocation Assistance

www.alliancetenerife.com

Office: 922 77 77 47

Email: info@alliancetenerife.com





Costa del Silencio, Drago



- 1 bedroom
- 1 bathroom
- Close to amenities
- Mountain views
- Furnished
- Sunny terrace
- Communal pool
- Communal parking
- Gated complex

🏠 45 🏠 8

Price: 94,000€ Ref: 1A3434

El Madroñal, 3 bedroom Villa



- 3 bedrooms
- 3 bathrooms
- Close to amenities
- Sea and mountain views
- Fully furnished
- Sep. s/c apartment
- Al fresco dining area
- Large sunny terrace
- Underground parking

🏠 200 🏠 150

Price: 480,000€ Ref: 3V3176

Guia de Isora, Canarian House



- 5 bedrooms
- 1 bathroom
- Close to amenities
- Sea and mountain views
- Furnished
- Spacious accommodation
- Mature garden
- Roof Terrace
- Private parking

🏠 95 🏠 350

Price: 320,000€ Ref: 5CH3435

Las Americas, Olimpia



- 1 bedroom
- 1 bathroom
- Touristic Area
- Gated community
- Close to beach
- Sea and pool views
- Furnished
- Sunny terrace
- Communal pool and parking

🏠 53 🏠 10

Price: 239,000€ Ref: 1A3439

EL MADROÑAL, OASIS DE FAÑABE



- 3 bedrooms
- 3 bathrooms
- Centrally-located
- Close to amenities and beach
- Part-furnished
- Double glazing
- Various sunny terraces
- Double garage
- Community pool

🏠 73 🏠 71

Price: 367,500€ Ref: 3TH3421

Costa del Silencio, Alondras Park



- 2 bedrooms
- 1 bathroom
- Gated community
- Close to the coast
- Close to amenities
- Immaculate condition
- Furnished
- Sunny terrace
- Community pool

🏠 77 🏠 6

Price: 132,000€ Ref: 2D3436

San Eugenio Bajo, Ponderosa



- Studio
- 1 bathroom
- Close to beach/amenities
- Touristic Area
- Sea and La Gomera views
- Furnished
- Sunny terrace
- Community pool
- Satellite TV

🏠 34 🏠 6

Price: 155,000€ Ref: 0S3432

Torviscas Alto, Balcon Andalicia



- 2 bedrooms
- 1 bathroom
- Close to amenities
- Sea views
- Furnished
- Central
- Sunny terrace
- Community pool
- Satellite TV

🏠 50 🏠 22

Price: 199,500€ Ref: 2A3428

San Eugenio Alto, Island Village Heights





- 1 bedroom
- 1 bathroom
- Close to amenities
- Gated community
- Touristic Area
- Sea and La Gomera views
- Furnished
- Sunny terrace
- Community pool



🏠 49 🏠 7

Price: 190,000€ Ref: 1A3399

Granadilla, Beautiful villa





- 4 bedrooms
- 3 bathrooms
- Sea and Mt Teide views
- Fully furnished
- Immaculate/spacious
- Own pool/guest apt.
- Garage/parking
- Various terraces/gardens
- Many extras!

🏠 304 🏠 850

Price: 578,000€ Ref: 4V3285

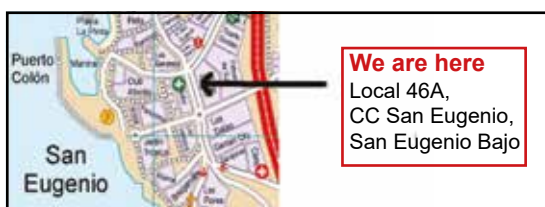

- Bank Repossessions
- Luxury Villas
- Resort and Residential Properties
- Investment Opportunities
- New Developments
- Relocation Assistance

www.alliancetenerife.com

Office: 922 77 77 47

Email: info@alliancetenerife.com





*Tenerifehome wishes
everyone a warm and joyful
Christmas!*



Est. 2007

www.tenerifehome.com

Follow us on Fb



Costa del Silencio, Parque Don Jose

Comfortable, renovated, fully furnished 1 bed apartment with 10sqm west-facing terrace. The property has a modern kitchen and includes an electric sunblind on the terrace! Spectacular complex swimming pool!

Ref: 1483-0419

€155,000



Costa del Silencio, Atlantic View

Fully furnished 1 bed, 1 bath ground floor apartment on popular sea front complex with pool. The property has two sunny terraces, a semi-separate kitchen and air conditioning in the bedroom. Easy parking!

Ref: 1489-0619

€126,900



Costa del Silencio

Spacious, fully furnished, 2 bed apartment with south facing terrace overlooking the gardens. Bathroom and kitchen recently renovated. The complex offers a spectacular heated swimming pool. Easy street parking.

Ref: 1354-0218

€185,000



Costa del Silencio, Parque Don Luis

Completely renovated 2 bed, 1 bath ground apartment with modern open kitchen in popular complex close to the coast and all amenities. Beautifully furnished sunny terrace.

Ref: 24-1119

€172,000



Costa del Silencio, Amarilla Bay

Spacious (60sqm), fully furnished, 1 bed, 1 bath apartment overlooking the 'Yellow Mountain' in complex close to the sea front. The property has a lounge/diner, open kitchen and sunny terrace with beautiful sea views.

Ref: 20-1019

€179,000



Costa del Silencio, Costa Sol

Fantastic, fully furnished, 2 bed, 1 bath ground floor apartment in sea front complex with lovely pool and close to all amenities. Semi-separate kitchen, lounge/diner and spacious (16.96sqm) sunny terrace.

Ref: 19-1019

€220,000



Costa del Silencio, La Baraca

Very nice, fully furnished, 1 bed, 1 bath penthouse apartment on popular complex with lovely pool area. The property has a lounge/diner, open kitchen, sunny balcony overlooking the pool and a roof terrace with spectacular views of Mt Teide.

Ref: 15-0919

€159,000



Costa del Silencio, Parque Don Jose

Fully furnished 1 bed, 1 bath ground floor apartment on popular complex with lovely pool area. The property has a lounge/diner, open kitchen and spacious terrace with 25sqm awning!

Ref: 10-0919

€149,000



Costa del Silencio, Gananana

Fully furnished 2.5 bed, 2 bath corner townhouse with off road parking for 2 cars. The property has a living room, separate kitchen, spare room, roof terrace, a front garden and rear terrace with BBQ.

Ref: 09-0819

€239,500



San Isidro, Montana de Yaco

Very nice 2 bed, 2 bath apartment with spacious living/dining room, open plan kitchen and fantastic balcony with great sea views, located just 5 minutes' drive from San Isidro and 10 mins from the nearest beach at El Medano.

Ref: 1447-1218

€149,000

C.C. El Trebol, Local 37,
Avda. J. A. Tavio,
COSTA DEL SILENCIO,
38630, Tenerife.

We work efficiently, transparently,
and speak YOUR language!

English · Español · Français
Deutsch · Nederlands

+34 690 363 653
+34 922 783 066
info@tenerifehome.com



2NDHOME
TENERIFE

**Specialists in New Developments,
Resales & Rentals**



IN EXCLUSIVITY



Brand new project for sale in Palm-mar:
Enjoy leisure activities & peaceful
environment close to the sea.

DEVELOPER:
metrovacesa
EDIFICIO GARA

Apartment with 2 & 3 bedrooms
with parking space and storage room.

For more information
please contact us:

commercialdirector@secondhometenerife.com

Prices from:
344.000€



Dorothee Robert
Commercial Director
+34 628 608 469
commercialdirector@secondhometenerife.com



www.2ndhometenerife.com

Terrazas del Duque
Av. Bruselas, 18
Edf. Terrazas del duque. Local 6
Costa Adeje
Tel. 922 715 591

Plaza del Duque
CC Plaza del Duque
Nivel -1, Kiosko E
38660 Costa Adeje
Tel. 922 718 193

Palm-Mar
C/ La Garza, 2
Edf. Terrazas del Faro
Arona
Tel. 922 748 006

Playa Paraiso
Av. Playa Paraiso, 2
Edf. Gran Azul, local 11
38678 Playa Paraiso
Tel. 922 741 866

Jardín La Caleta
Av. de Las Gaviotas, 35
Local 1
La Caleta
Tel. 922 168 058

TENERIFE PROPERTY SHOP S.L.

G.I.P.E. NO. 3722

Service

Security

- ✓ Reliability
- ✓ Professionalism
- ✓ Security
- ✓ Service
- ✓ The BEST Portfolio

OUR OFFICE LOCATIONS:

CC San Blas - Golf del Sur

Las Adelfas I - Golf del Sur

CC Puerto Colon - Playa de Las Américas



NEW!
EXCLUSIVE

1 BED APARTMENT

Golf del Sur

GREAT STARTER OPPORTUNITY!

A great opportunity to climb onto the Tenerife property ladder with this very spacious one bedroom apartment within an established complex with reception, three communal pools, on-site bar and restaurant, supermarket, and more. The apartment is on the 1st floor and lift access is available. As well as the regular living areas, there is a alcove that is currently utilised as a separate sleeping area but could be an office.

Ref: GOLF01601

Price: €105,000 (approx. £90,517)



EXCLUSIVE

1 BED APARTMENT

Golf del Sur

TURNKEY PROPERTY!

If you are in the market for a property that offers that home from home feel, then look no further than this spacious one bedroom apartment that has been furnished to a beautiful standard and is ready to move into.

The apartment offers a generous 56m² and is sold with an underground parking space, which is worth its weight in gold.

Sold as seen, don't miss out!

Ref: GOLF01591

Price: €145,000 (approx. £125,000)



EXCLUSIVE

1 BED APARTMENT

Los Cristianos

IDEAL HOLIDAY HOME!

This very well presented one bedroom apartment is absolutely ideal as a holiday home for both summer or winter! Located on a pleasant complex with a community pool and it has lovely sea views. The apartment is light and bright with a good sized lounge, fitted kitchen and a double bedroom with additional space to fit a 'put up bed' for the kids...the complex also has a pool bar onsite.

Ref: LC00585

Price: €170,000 (approx. £146,552)



3 BED BUNGALOW

Chayofa

IDYLIC HIDEAWAY!

If peace and tranquility are on your search list, then this immaculately presented bungalow should be top of your viewing list. Located on a quiet complex in the pretty village of Chayofa, not far from Los Cristianos. Three double bedrooms, two of which have en-suite bathrooms. Open plan fitted kitchen looks out to the bright spacious lounge area which leads onto the large lower terrace.

Ref: OUT01105

Price: €230,000 (approx. £198,276)



REDUCED!!!

3 BED APARTMENT

Golf del Sur

AIR CONDITIONED PENTHOUSE!

Fantastic three bedroom property that has been lovingly maintained and is situated in a top development in the South of Tenerife. With a pick of golf courses, promenade walk, bars, restaurants, shops and marina on your doorstep you will not want to leave. The complex is built to a high standard and the penthouse apartments boast marble floors and air conditioning throughout.

Ref: GOLF01552

Previously £250,000

Price: £219,500 (approx. €254,620)



2 BED LINKED HOUSE

Golf del Sur

THE PERFECT HOME!

This two bedroom, two bathroom, two storey house has been completely refurbished with a modern finish. Set in a quiet residential development with two communal pools this property represents the perfect home, whether it is for living permanently or holidaying. The development is very secure and the main swimming pool has been recently refurbished and is heated in the cooler months of the year.

Ref: GOLF01585

Price: €269,500 (approx. £232,328)

www.tenerifepropertyshop.com

NEW!
EXCLUSIVE



This fabulous detached villa exudes quality. Bespoke Teak furniture designed by the owner of the property and imported directly from Thailand is a theme throughout the whole property. Comfortable living areas both inside and outside. A private pool and sun terrace with panoramic views of Costa Adeje and remarkable sunsets to enjoy all year round. **SEE THE VIDEO TOUR ON OUR WEBSITE!**

Ref: LA01860
Price: €840,000
(approx. £724,138)



★★★★★

BEST REAL ESTATE
AGENCY SINGLE
OFFICE CANARY
ISLANDS

Tenerife Property Shop S.L.

2019-2020



AWARD WINNER

REAL ESTATE AGENCY
WEBSITE SPAIN

www.tenerifepropertyshop.com
by Tenerife Property Shop S.L.

2019-2020



EXCLUSIVE ★★ ★ PROPERTY OF THE MONTH! ★★ ★

BUY-OFF-PLAN
LUXURY
 New Development
 ON AMARILLA GOLF
 PRICES FROM
 €390,000



Want to BOOST your property exposure?
 Have a professional VIDEO presentation made!
 FOR MORE DETAILS.. Call 922 714 700



2 BED APARTMENT
 Amarilla Golf
PENTHOUSE WITH ROOF TERRACE!
 If you are looking for a home that's a cut above the rest, then you have to take a look at this very spacious two bedroom penthouse which offers a blank canvas and the ideal opportunity for you to pop your interior designer hat on. Fully equipped kitchen, garage & a massive roof terrace: you'll be throwing some great parties, if you can stop your friends gawping at the gorgeous view over the fairways to the ocean.
 Ref: AMG00548
 Price: €295,000 (approx. £254,310)



3 BED VILLA
 Chayofa
PERFECT RESIDENTIAL PROPERTY!
 This charming detached property nestles in the pleasant area of Chayofa and is only a few minutes from Los Cristianos. It is a perfect location if you enjoy a more residential and quieter environment, yet close enough to the busier resorts. Panoramic views of the countryside and to the Ocean, mature garden areas with a private pool and sun terraces. Inside is light, bright and well presented.
 Ref: OUT01117
 Price: €345,000 (approx. £297,414)



2 BED APARTMENT
 San Eugenio Bajo
CLOSE TO SEA FRONT!
 A well presented and spacious two bedroom, two bathroom ground floor apartment in the popular Santa Maria Aparthotel in the heart of San Eugenio Bajo. The apartment has 71m² living area and an excellent 47m² of terrace with sea views and a south facing aspect ensuring plenty sun all year round! The complex has a 24 hour reception, pool bar, community pool and gardens. Rental scheme available.
 Ref: OUT01140
 Price: €349,950 (approx. £301,681)



2 BED APARTMENT
 Playa Paraiso
MODERN CORNER PROPERTY!
 This corner two bed, two bath apartment on this newly completed development is situated in a privileged location offering magnificent views to the sea and the neighbouring island of La Gomera. Finished to a high modern standard, with a large terrace of 45m² offering all day sun, and private underground parking. Partly furnished, the property is just waiting for someone to add those finishing touches.
 Ref: OUT01140
 Price: €385,000 (approx. £331,897)



4 BED VILLA
 Golf del Sur
SPACIOUS VILLA WITH ANNEX!
 Situated on a plot of over 1000m². This property has a large, open lounge that is clearly the hub of the villa. The kitchen is a real show stopper. The master bedroom has a modern en-suite. Bedrooms two and three share the large family bathroom with jacuzzi. Furnished. This property also has a completely separate annex which is home to a one bedroom duplex apartment. Close to all amenities.
 Ref: GOLF01455 Previously €575,000
 Price: €525,000 (approx. £449,955)



2 BED VILLA
 San Eugenio Alto
PRESTIGIOUS LOCATION!
 A beautiful two bedroom, two bathroom detached villa with private pool located in the prestigious San Eugenio Alto area of Costa Adeje. If you are searching for a holiday home or a permanent residence then this is perfect. Excellent location, panoramic views to the Coast and surrounding area from the pool area and the roof terrace! There is also an impressive double garage under the villa.
 Ref: LA01843
 Price: €675,000 (approx. £581,897)

We don't make promises. We give GUARANTEES!



Two generations of a Family Business • Over 30 Years of Experience
 Service & Security in your purchase • Professional Indemnity Insurance
 20 Year Insured Title Deed Guarantee

☎ 0034 922 714 700 / 0034 922 715 064

From UK: 0845 862 1634



info@tenerifepropertyshop.com

Christmas Prize Draw!!!

To win a Hamper full of Goodies visit us on our Facebook page

Find us on  @TenerifePropertyShop





PALM MAR SALES & RENTALS

**ALL ASPECTS OF PROPERTY MANAGEMENT SALES
& LONG TERM RENTALS**

Tel: 0034 677 623 713 / 0034 671 129 558 • email: info@palmmarsalesandrentals.com • www.palmmarsalesandrentals.com

Palm Mar, Bahia de Los Menceyes



Luxury 1 bed, 2 bath apartment on this prestigious development which is just a short stroll to the sea front. It is sold furnished and the price includes secure underground parking space and a storeroom.

Price: €310,000

Palm Mar, Laderas de Palm Mar



This delightful 1 bed, 1 bath apartment has a sunny aspect and overlooks the lovely pool area. It is bright and spacious throughout and is sold furnished.

Price: €179,995

WE ARE ALWAYS LOOKING FOR NEW PROPERTIES FOR SALE AND LONG TERM RENTAL

Palm Mar, Paraiso del Palm Mar II



Beautifully presented, bright and spacious, fully furnished 2 bed, 2 bath apartment with a rooftop solarium with all-day sun. Marvellous views over the village to the sea.

Price: €285,000

Residencial San Blas



Spacious, fully furnished 3 bed, 2 bath (1 en suite) linked house on this small residential complex with delightful pool and close to the sea. There are views of mount Teide at the front of the house and sea view from the rear.

Price: €335,000

Palm Mar, Paraiso del Palmar I



Bright and spacious 1 bed, 1 bath apartment that overlooks the nature reserve. It has wonderful views and the benefit of a large sun terrace upstairs. The property is beautifully presented and is sold fully furnished.

Price: €187,000

Palm Mar, Los Balandros

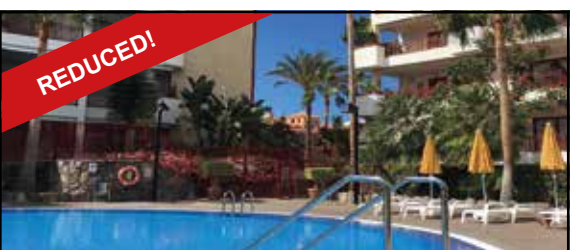

Bright and spacious 1 bed, 1 bath duplex apartment with all day sunshine and views over the 49sqm pool out to La Gomera from the large upper terrace. Sold furnished, the property has the opportunity to utilise the additional upstairs room as a second bedroom.

Price: €189,000

Palm Mar, Lovely villa



Fully refurbished and furnished, bright and spacious 4 bed, 2 bath villa in the heart of the village. The property enjoys sea views from the solarium and there is an integrated garage.

Price: €499,500

Palm Mar, Club de Mar



Spacious, fully furnished, 3 bed, 2 bath (master en suite), plus cloakroom, townhouse on three levels in the lovely coastal village of Palm Mar. There is also a very large integral garage and pleasant garden.

Price: €410,000



TENERIFE PROPERTIES



ENGLISH / ESPAÑOL / FRANÇAIS / ITALIANO - 608 573 443

Контактный телефон для русскоговорящих - 648 525 024

Club Atlantis, San Eugenio

NEW INSTRUCTION

Luxury 1 bed, 1 bath apartment, fully refurbished.

€390,000 Ref: N1375

Club Atlantis, San Eugenio

NEW INSTRUCTION

Penthouse studio apartment. Front line.

€295,000 Ref: A426

Oasis, San Eugenio

NEW INSTRUCTION

1 bed, 1 bath apartment, fully refurbished throughout.

€150,000 Ref: N1378

Ocean Park Phase I, San Eugenio

PENTHOUSE!

1 bed, 1 ½ bath duplex apartment with extra sleeping room and 2 terraces.

€239,000 Ref: N1372

Elite Palace, El Duque

NEW INSTRUCTION

1 bed, 1 bath apartment with large terrace and sea views. Garage space incl.

€249,000 Ref: N1366

Villamar, San Eugenio

EXCLUSIVE!

Beautiful studio apartment in fantastic position right on the sea front with amazing views of the sea in this sought-after complex. This property has a fully equipped kitchen, bathroom, living / sleeping area and a terrace from which you can enjoy unbeatable sea views. The complex is secure and is in a fantastic location, and has a communal heated swimming pool, large sunbathing area, gardens, a lift and parking.

€275,000 Ref: A431

PROPERTIES ARE IN DEMAND! WE OFFER A FREE VALUATION!

SPECIAL OFFER: ENERGY EFFICIENCY CERTIFICATES PLEASE CALL US FOR MORE INFORMATION!

Andalucia, Torviscas Alto

WHEELCHAIR FRIENDLY!

Beautiful 2 bed, 2 bath apartment situated on the same level as the pool in popular apart hotel. This spacious apartment has been fully refurbished throughout to a very high standard and has a large lounge / dining room with American kitchen, an internal patio and a very large wraparound terrace with views to the pool area and over to the sea. The complex has a lift and the property is suitable for wheelchair and disabled access.

€315,000 Ref: T1181

Falcon Manor, San Eugenio Alto

LUXURY!

2 bed, 2 bath luxury apartment with large terrace and garage.

€475,000 Ref: T1180

Palo Blanco, San Eugenio

NEW INSTRUCTION

2 bed, 1 bath bungalow with sea views.

€299,000 Ref: T1179

Roque del Conde, Torviscas Alto

2 bed, 1 bath apartment with big terrace and sea views. Garage space incl.

€210,000 Ref: T1177

Los Geranios, San Eugenio

2 bed, 1 bath apartment with double terrace and sea views.

€315,000 Ref: T1174

Detached villa, Palm Mar

LUXURY!

4 bed, 4 bath detached luxury villa. Wheelchair friendly.

€995,000 Ref: L1265

Translators available for any other languages.



Tel: 922 724 110 • Sales: Lynne: 699 250 870 Rachel: 608 573 443
 Local 3, C.C. Palo Blanco, San Eugenio, Adeje 38660, Playa de las Americas
 www.tenerifeproperties.net • lynne@tenerifeproperties.net



T: (0034) 922 732862
 M:(0034) 683 190 977
 info@rdproptiestenerife.com

Calle Luis Alvarez Cruz,
 nº6, Edf Bahia Azul, Local 8C
 Las Galletas - Next to post office



GREAT INVESTMENT OPPORTUNITY!



GUAZA

Complete, fully furnished and equipped building in great location and in excellent condition suitable for, amongst other things, B&B, long term rentals, rentals or conversion to separate apartments. Lots of potential for high profit/return on investment.

with plants and flowers; the 1st floor has a 4 bedroom, 2 bathroom house with laundry and 2 terraces; the 2nd floor has 4 apartments, each with terrace; and the top (4th) floor is an attic measuring 150sqm with the potential to convert into 2 separate studio apartments.

The Canarian-style building (total 701sqm) has 2 separate entrances and incorporates 10 apartments and a 150sqm house. On the ground floor is a large kitchen and interior garden

Due to its excellent location the property has all services close by, and easy access to the TF-1 / airport etc .



Call for information quoting Ref GB3-G1X5



rdproptiestenerife.com

Tel: 922 719 643
 Fax: 922 781523
 Mobile: 607 933 052
 Mobile: 625 950 517



Calle Tagara,
 Jardin Botanico
 Local 8
 ADEJE













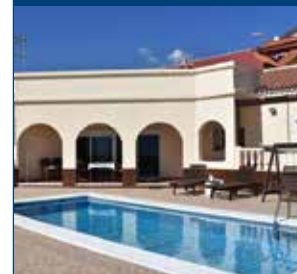

OPPORTUNITY OF THE MONTH!

TEJINA DE GUIA	ADEJE, LAS TORRES	PLAYA DE LA ARENA	SANTIAGO DEL TEIDE
 <p>NEGOTIABLE!</p> <p>Great opportunity to build 2 smaller houses or one large one. Lots of potential here. This plot has a derelict house with lots of urban land surrounding it. Plot 755sqm. Fantastic views.</p>	 <p>Very nice, spacious, centrally-located, fully furnished, 2 bed, 2 bath duplex with living room, kitchen and parking space. Great situation close to everything - perfect to live in.</p>	 <p>First line property. Corner townhouse on 3 floors with terrace and garage on complex with pool. Potential to build a pool on the terrace. Needs reforming. Fantastic sea views.</p>	 <p>REDUCED!</p> <p>6 bed, 6 bath hostel – ideal for young people. Fully legal. Several lounges and kitchen. It also has a detached house and potential to build more. High score and rentability.</p>
Ref: 1092 €235,000	Ref: 1094 €178,500	Ref: 1096 €210,000	Ref: 756 €560,000

**We cover the whole of the South ...
 That's why we have two Offices (in Adeje and Alcala!)**

**PROPERTIES WANTED FOR RENT
 CLIENTS WAITING!**

 <p>REDUCED!</p> <p>Beautifully furnished, 4 bed, 3 bath villa with own pool. The property has various terraces, a utility room, garage, and is very central. Fantastic residential area.</p>	 <p>Beautiful, luxuriously furnished, 2 bed (both double), 1 bath penthouse with terrace located close to the coast. Awesome sea views!</p>	 <p>WONDERFUL VIEWS!</p> <p>Great finca (5,450sqm) with a 3 bed main house, 2 sep. apartments, and an independent guest property – plus pool, BBQ area, garden with fruit trees, and beautiful views.</p>	 <p>Great finca with 90 hectares of land. 3 houses (one suitable for reform), water tank and 15.000 vine vineyard. Lots of potential. Possible to buy less land plus the houses for €475,000.</p>	 <p>Spacious and bright, fully furnished, 3 bed, 2 bath villa with living room, kitchen, several terraces, pool, garden and storeroom, plus small, separate studio.</p>	 <p>A variety of luxury villas and townhouses for sale - several complete, some under construction. Great views over the golf course to Playa san Juan.</p>
Ref: 1036 €649,000	Ref: 1079 €300,000	Ref: 1061 €1,395,000	Ref: 727 €1,050,000	Ref: 1066 €620,000	Ref: 1097 €various
 <p>Fantastic 10,000sqm finca with house, trees, terraces, beautiful views and much more. Rural area.</p>	 <p>Finca (6,000sqm) with rustic 10 bed main house with containers converted into common rooms, several terraces, gardens with fruit trees, water tank for irrigation and two caves.</p>	 <p>Finca (12,500sqm) with small (30sqm) house to reform, several terraces and really excellent views.</p>	 <p>Very central 3 bed apartment with modern kitchen, dressing room and 2 parking spaces. Close to all amenities.</p>	 <p>Spacious, furnished, 3 bed, 2 bath + WC townhouse on 3 floors on community with pool. The property has a lounge/diner, balcony with sea views, 110sqm terrace and garage.</p>	 <p>We have a wide variety of working and ex-banana plantations throughout Tenerife, some with habitable properties, other suitable for reform – wide range of prices!</p>
Ref: 837 €150,000	Ref: 1052 €196,000	Ref: 828 €147,000	Ref: 1074 €190,000	Ref: 1095 €399,000	Ref: xx from €200,000

NEW

Townhouse in Parque de la Reina



- Cho urbanization La Perla
- 3 bedrooms, 2 bathrooms
- Fully refurbished
- Ref: D1184
- Price: 260,000€

This townhouse of 147m2 has two floors and consists of three bedrooms, three bathrooms, a separate kitchen, living room and a balcony. In addition is a large garden surrounding the house and a private garage. The house is renovated and is sold furnished.

NEW

House in El Madronal



- El Madroñal, Costa Adeje
- 3 bedrooms, 2 bathrooms
- Private pool
- Ref: D1154
- Price: 515,000€

This house is 140m2 consists of three bedrooms, two bathrooms, a separate kitchen, a spacious living room and a balcony overlooking the sea and the mountains. Moreover, there is a 60m2 private garden with a private (heated) pool and a garage. The villa is sold furnished.

✉ frina@tenerife-property.com

☎ +34 683 479 245 ☎ +34 617 29 48 03

🌐 www.tenerife-property.com

🏠 CC Puerto Colón, 1st Floor, local 213, 38660 Adeje

FRINA Tenerife S.L.
Business & Property Agency



MK PROPERTY AND MONEY EXCHANGE

C.C. CITY CENTER - L22 PLAYA DE LAS AMERICAS - ARONA 38660 - TENERIFE

Tel: 922 751 693 / Mob: 630 994 991 - Email: marykilmartin333@gmail.com



Los Cristianos, Parque Tropical



Superb, fully furnished, 3 bed, 3 bath duplex penthouse apartment on sought after complex with lovely pool area. The property has 2 large sunny terraces, fantastic views and is located just 200 metres from the beach.

Price: €390,000

San Eugenio Alto, Paradise Court



Large, fully furnished 1 bedroom apartment with sea views on a sought after, secure complex with heated pool, Reception and bar/restaurant. Ideal Investment.

Price: €145,000

Costa del Silencio, Garanana



Fantastic, totally reformed 5 bed house. The property is furnished to a very high level, has a modern kitchen and aircon throughout. Must be seen!

Price: €242,000

Adeje, Jardin Botanico



Fantastic 3 bed, 2 bath (+WC) family home in sought after complex with lovely pool area. The property has a large lounge/diner, independent kitchen and a large garage/storeroom. Close to amenities/schools etc.

Price: €255,000

Las Americas, Parque Santiago II



Want a view like this? Superb, refurbished, 2 bed, 2 bath corner property in the tower on the sea side of this top complex. The property has a large wrap-around terrace and spacious lounge.

Price: €365,000

Callao Salvaje, Mariben



Superb 2 bed, 2 bath (both en suite) corner townhouse on this prestigious complex. The property has a bright lounge, independent kitchen and a large 2-car garage with lots of storage space.

Price: €299,000

Las Americas, Parque Santiago II



Superb, fully furnished and refurbished, 2 bed, 2 bath duplex apartment on this top sea front complex. The property has a large terrace with lovely views, and is fully air-conditioned.

Price: €379,000

Callao Salvaje, Luxury villa



3 bed, 3 bath independent villa 2 totally independent apartments (one a two bed, the other, a one bed). The main house has a large lounge/dining area, independent kitchen, Must be seen!

Price: €999,000

CALL: +34 922 790767
 UK FREEPHONE: 0800 802 1669
 EMAIL: INFO@ISLANDESTATES.ES
 WWW.ISLANDESTATES.ES

facebook twitter

FAIRWAYS, Amarilla Golf

NEW LISTING!

Ref: 558-S

Large penthouse studio apartment at a bargain price. This property has a lounge with bedroom area, fitted wardrobes, bathroom and a small fitted kitchen. Large private sunny terrace with golf and partial sea views. Excellent community with large pool and gardens.

0 bed, 1 bath 99.950€

GREEN PARK, Golf del Sur

REDUCED TO SELL!

Ref: 429-A1

Large apartment at a bargain price. This property has a large double bedroom with fitted wardrobes, an open plan bedroom off the lounge, and a small kitchen. Private terrace with pool and partial sea views. The community fees are good and all inclusive. And the communal areas have just been refurbished. Call for a viewing.

2 bed, 1 bath now 114.500€

LOS DIAMANTES, LOS CRISTIANOS

NEW LISTING

Ref: 549-A1

Well presented, fully furnished 1 bed, 1 bath ground floor apartment with pool views. The property has a double bedroom, refurbished bathroom, new kitchen and lounge, sunny terrace and heated community with pool. Viewing highly recommended.

1 bed, 1 bath 137.000€

FAIRWAYS, Amarilla Golf

BARGAIN!

Ref: 559-A2

2 bed, 2 bath apartment with 2 terraces. Offered well presented, part refurbished and fully furnished. Fitted and equipped kitchen, fitted wardrobes. Excellent community with pools, and gardens. Priced to sell, viewing recommended.

2 bed, 2 bath 169.950€

ATALAYA COURT, San Eugenio Alto

NEW LISTING!

Ref: 553-A2

Amazing offer – Original 2 bedroom apartment with large lounge, American style kitchen, bathroom, terrace and 60m² private roof terrace with BBQ, and sea views. Would benefit from light refurbishment. Located close to the Gran Sur Shopping centre, with supermarket and cinema. Community close to town, with Swimming pool and Gardens. Genuine reason for sale – outstanding value, unbeatable offer.

2 bed, 1 bath 135.000€

OASIS, ALDEA BLANCA

NEW LISTING

Ref: 551-82

Beautiful fully refurbished modern private bungalow, well located on this small community with recently refurbished swimming pool. Two double bedrooms, lounge, and modern brand new fully fitted and equipped kitchen. Approx 80m² of private terrace.

2 bed, 1 bath 159.000€

JARDIN SAN MIGUEL, Llanos de Camello

IMMACULATE!

Ref: 335-TH4

Large, very well presented town house offering four bedrooms two bathrooms and W.C., large lounge and separate modern fully fitted kitchen. Terrace with pool views, and private double garage with direct access- Very well presented.

4 bed, 2 bath 225.000€

MALPAIS, Guimar

NEW LISTING!

Ref: 554-V3

Rare opportunity. Large rustic house on a plot of over 2.500m² in a beautiful quiet, and very private part of the Island. Sea and mountain views. This property is a dream for anyone looking for peace and tranquillity, three double bedrooms, rustic style independent kitchen adjacent dining room. Room for animals, mature fruit trees. Private garage.

3 bed, 1 bath 225.000€

MALVASIA, Llano del Camello

PRICE DROP!

Ref: 547-TH3

Modern, refurbished, 3 bed, 3 bath corner townhouse with large garden, on a community with pool. Offering lounge / dining room, independent kitted and equipped kitchen, and views to the sea. Private parking, viewing recommended.

3 bed, 3 bath 225.000€

CHAYOFA COUNTRY CLUB

NEW LISTING!

Ref: 543-A2

Large 2 bed, 2 bath apartment on this popular resort. Offered furnished and with a rental option, this large apartment has a fully equipped kitchen, lounge / dining room and large private terrace. Great community facilities.

2 bed, 2 bath 230.000€

ALAMO PARK, Golf del Sur

NEW LISTING!

Ref: 555-V7

Absolutely stunning villa. Tastefully decorated throughout. The property is the main 4 bed villa (all en suite) and a 3 bed guest apartment with its own lounge and kitchen. Separate entrance to three bedroom apartment with lounge and kitchen. Beautiful gardens surround the private swimming pool. Too many extras to list. Viewing is essential.

7 bed, 5 bath 695.000€

PRIMAVERA, Los Cristianos

NEW LISTING!

Ref: 524-V3

RARE OPPORTUNITY. Fantastic apartment in a great location. Well presented with semi-separate fitted and equipped kitchen, dining area and lounge, two double bedrooms, and full bathroom. Private terrace of over 15m², on a resort with swimming pool. Close to beach.

2 bed, 1 bath 260.000€

YOU'LL FIND OUR OFFICE ACROSS FROM THE FOOTBALL STADIUM IN PLAYA DE LAS AMERICAS

ADVERTISE YOUR PROPERTY WITH US AND SEE YOUR PROPERTY PROMOTED WITH RIGHTMOVE AND ZOOPLA IN THE UK AND KYERO ACROSS EUROPE.

Local 1, Las Floritas, , Avenida Arquitecto Gomez Cuesta 16, Playa de las Americas, Arona 38660, Santa Cruz de Tenerife





CLEAR BLUE SKIES GROUP SL
INTERNATIONAL ESTATE AGENTS

E 3 2 Ref: 7609
LAS CHAFIRAS

Apartment **€149,950**

F 2 2 Ref: 7607
PALM MAR

Apartment **€184,950**

F 2 1 Ref: 7597
SAN ISIDRO

Apartment **€115,000**

G 1 1 Ref: 7570
AMARILLA GOLF

Apartment **€130,000**

G 2 2 Ref: 7588
TORVISCAS ALTO

Townhouse **€395,000**

G 3 2 Ref: 7586
LLANO DEL CAMELLO

Apartment **€155,000**

E 4 4 Ref: 7578
ADEJE

Villa **€649,000**

G 4 2 Ref: 7557
TAUCHO

Rustic House **€368,000**

E 3 2 Ref: 7522
EL MADRONAL

Townhouse **€330,000**

E 2 1 Ref: 7518
TORVISCAS ALTO

Apartment **€179,000**

Season's greetings from all the team at Clear Blue Skies!

G 1 Ref: 7625
PLAYA FAÑABÉ

Studio **€199,950**

G 5 4 Ref: 7436
CALLAO SALVAJE

Villa **€745,000**

E 1 1 Ref: 7424
LOS CRISTIANOS

Apartment **€180,000**

G 1 1 Ref: 7414
EL MADRONAL

Apartment **€190,000**

E 1 1 Ref: 7393
SAN EUGENIO ALTO

Apartment **€165,000**

G 2 2 Ref: 7329
LOS CRISTIANOS

Apartment **€199,000**

G 5 2 Ref: 7141
VILLA DE ARICO

Village House **€299,000**

G 1 1 Ref: 7613
LOS CRISTIANOS

Apartment **€185,000**

D 2 2 Ref: 7630
ADEJE

Apartment **€250,000**

G 3 2 Ref: 7554
PLAYA DE SAN JUAN

Duplex **€210,000**



CLEAR BLUE SKIES GROUP SL
INTERNATIONAL ESTATE AGENTS



G 1 1

Ref: 7614

LOS CRISTIANOS

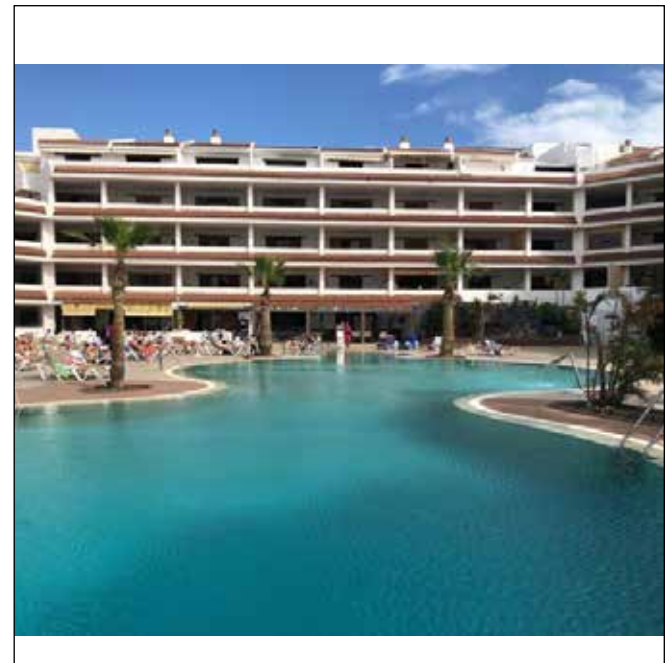

A great chance to purchase a 1 bedroom apartment on the popular front line complex of Paloma Beach in Los Cristianos. The apartment has good rental potential due to the location of the complex and the fact it has an onsite reception that rents out the apartments for the owners. The apartment consists of a double bedroom, family bathroom, American style kitchen with breakfast bar, spacious lounge area that's open out on to a terrace that overlooks the communal gardens and also a view down the path to the sea. Ideal as a winter holiday home with investment potential.

Apartment €219,950

We have clients looking for properties in Adeje Park, Mesitas del Mar and Oasis La Caleta. If you are thinking of selling, please call us TODAY!

G 2 1 (+WC)

Ref: 7598

PALM MAR



Delightful penthouse apartment in Phase I of the sought after residential complex Paraíso del Palm-Mar. A recently renovated shower room and the two double bedrooms are located at ground floor level with built-in wardrobes and both with direct access to a spacious terrace of 16m². The main living area is on the first floor and is flooded with natural light, consisting of a living-dining area with an open kitchen which has also been recently renovated plus a guest toilet with laundry area. Large sunny front terrace with panoramic sea & nature reserve views as well as a rear terrace giving access to the roof terrace via a spiral staircase. The large roof terrace (42m²) boasts even more spectacular panoramic views. Also included is a parking space in the communal garage.



Duplex €365,000



Avda Londres 1, Sur y Sol, Local 1
Los Cristianos, Arona 38650

Office: 922 797 438 / 922 751 587
Mobile: (00 34) 673 778 700

www.tenerifeislandrentals.com
info@tenerifeislandrentals.com



Tenerife Island Rentals & Buy Tenerife

Sales

EDIFICIO JACOBINA, ADEJE



Lovely one-bedroom apartment in Central Adeje, conveniently situated for amenities, restaurants, transport and shops. The apartment comprises of bathroom, double bedroom with fitted wardrobe, living room with American style kitchen and utility room on the roof terrace. This apartment has sound proof walls, pre installation for both air conditioning and solar panels. Very quiet location.

Ref: AP0529

€98,000

SAND CLUB, GOLF DEL SUR



Lovely apartment next to the golf course and close to all amenities in Golf del Sur. This lovely apartment has been tastefully renovated and decorated and comprises of bathroom, spacious double bedroom with wardrobe and golf course views, fully fitted American style kitchen, living room with dining area and a cozy terrace to enjoy the tranquility of this quiet complex. The location of the apartment is excellent as it has direct access from the main street. Only five minutes walking from shops, bars and restaurants in Golf del Sur. Ideal holiday home.

Ref: AP0530

€139,000

LAS TAJINASTES, PLAYA DE LAS AMÉRICAS



Fifth floor apartment with lift access in very central area. This one-bedroom apartment has a large living room with American style kitchen and balcony and bathroom. Just a five-minute walk to the beach front of Playa de las Américas and surrounded by bars, restaurants and shops. Fantastic location and an ideal holiday apartment or investment.

Ref: AP0513

€165,000

CASTLE HARBOUR, LOS CRISTIANOS



Duplex apartment with two bedrooms and two bathrooms in Castle Harbour. Good sized living room with kitchen area and nice balcony from the living room area. This is an ideal investment property or for a holiday home. There is a 24-hour reception, laundry, pool bar and large community swimming pool. There is also an on-site management company allowing holiday renting of this property.

Ref: DUP0512

€180,000

RESIDENCIAL TOPAZE, CALLAO SALVAJE



This spacious three-bedroom apartment is located on a well-kept complex in the centre of Callao Salvaje. The property consists of three double bedrooms with fitted wardrobes and the master bedroom has ensuite bathroom and a further family bathroom. There is a large living room with American style fitted kitchen and breakfast bar. A large balcony is accessed from the living area. Fantastic community swimming pool and sun terraces and resident car park. This apartment is in a great location of Callao Salvaje with plenty of restaurants and shops in the immediate area.

Ref: AP0507

€210,000

LOS GIRASOLES, EL MADROÑAL



Beautiful three-bedroom two-bathroom townhouse property in very popular complex in El Madroñal. On the lower level there is a fully fitted kitchen and utility area, WC and large living room with direct access to the front terrace. There is also a private rear garden. On the upper floor there is a large master bedroom with en suite bathroom and terrace with fantastic sea and coastal views and a further two double bedrooms and bathroom. There is also a small office area on the upper level. Parking area behind secure gates to the property. This is a very desirable property located in a secure complex with mature gardens.

Ref: ADO0438

€330,000



Address: C/ Colon, C.C. Centro Playa, Local 9,
Puerto Colon, Las Americas, Adeje 38660
Phone: 922 719925
E: info@thepropertygallery.com
www.thepropertygallery.com



SAN EUGENIO ALTO Price: €1,950,000 Ref: D1876



**Tenerife is
Life, Love and
Dreams Come True!**

**A Highly Unique Luxury Villa
that blends into the hillside
where luxurious amenities combine
with views to the Atlantic Ocean.**



**A Hidden Oasis of Greenery
offering privacy, and
a choice of seating/dining areas,
AND a lovely Winter garden!**



**Indoor and outdoor pools,
Stucco Veneciano on all
walls and ceilings.**



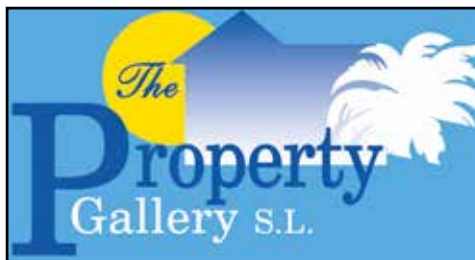

Address: C/ Colon, C.C. Centro Playa, Local 9,
Puerto Colon, Las Americas, Adeje 38660
Phone: 922 719925
E: info@thepropertygallery.com
www.thepropertygallery.com



**CHAYOFA COUNTRY CLUB,
CHAYOFA**



Very wide living area with plenty of light, dining area, American style fitted kitchen, spacious double bedroom, wardrobes and a good size bathroom, plus a very large terrace.

Ref: B1798 €151,250

**LAS FLORITAS,
LAST AMERICAS**



1 bed ground floor apt. (52sqm) with pool views in central Las Americas. The property has a lounge/dining area, open plan kitchen, and terrace with easy access to the pool. Sold as seen.

Ref: B1781 €163,500

**GREEN PARK,
GOLF DEL SUR**



Spacious and modern studio with an alcove for bed separate to the lounge, open plan kitchen, bathroom and a terrace to the exterior.

Ref: A411 €108,000

REPOSSESSIONS:

ARICO
Village house (124m2) with 3 beds and 2 baths, light and good size living areas, fitted wardrobes, fitted kitchen, sunny terrace. Needs renovation.
€140,700
Ref: 77916

€76,500
Ref: 00909
PLAYA SAN JUAN, C/ MAR DE FONDO,
1 bed, 1 bath apt with roof terrace and store room, open plan fitted kitchen.
€169,900
Ref: 52992

URBAN PLOT, GUIA DE ISORA
570sqm plot on which max build is 1,000sqm.
€108,600 (REDUCED!)
Ref: 37861

TERRAZAS DE LA PAZ, GOLF DEL SUR
1 bed, 1 bath top floor apt with lounge-diner, fitted kitchen, terrace (19 m2). Communal pool.
€177,870
Ref: 69417

SOL SUN BEACH, PLAYA DE FAÑABE
Commercial local, 22 m2.

**JARDIN DE BOTANICO,
ADEJE**



Spectacular townhouse in quiet area, 4/5 beds with fitted bathrooms and balconies, fully fitted kitchen, garage, fully furnished, air-con, internet, south facing, communal pool.

Ref: D1813 €275,000



ALREADY A LIBERTY SEGUROS CUSTOMER? TAKE OUT AN ADDITIONAL CAR OR HOME POLICY & GET 60€ CASHBACK.

**MIRADOR DEL SUR,
SAN EUGENIO ALTO**



Family home, 4 bed, 4 bath villa with private swimming pool, double garage, electrical shutters, air-con (hot & cold), several terraces, excellent views to sea and coast.

Ref: D1733 €735,000



Tenerife Alizés Properties

Sales and Rentals



Over 15 years' experience in business on the island.

Calle La Ballena, 17 bajo derecha, LOS ABRIGOS, Granadilla de Abona.

Tel: 922 738 653
Mob: 626 274 040

RESIDENTIAL SALES

LONG TERM RENTALS



**Los Abrigos,
2 bed apartment**

Bright and spacious, fully furnished, 2 bed (1 single, 1 double), 1 bath ground floor apartment, in residential building within walking distance to the sea and to the main shops and amenities. The property has an interior patio, living room with American style kitchen and use of the communal roof terrace. Includes a private laundry room. Low community fees.

Ref: KV-0163 €110,000



**Los Abrigos,
2 bedroom apartment**

Modern apartment (raised ground floor) in residential building with lift in central Los Abrigos. Fully furnished, 2 bed (1 double), 1 bath (with shower), living room, separate modern fitted kitchen and hallway. Close to the sea front and all main amenities. Use of the community roof terrace. Good opportunity as investment.

Ref: KV0227 €99,000



**Golf del Sur, 3
bedroom bungalow**

Large, fully furnished and equipped, 2 bed, 2 bath bungalow with sep. self-contained 1 bed apartment on popular complex with pools, bar/restaurant close to golf courses and main amenities. The main property has a separate modern kitchen, utility room, large terrace overlooking the communal pool, and private parking for 2 cars.

Ref: KV0203 €1,300/mth



Tenerife Prime Property

AMARILLA GOLF, PALM RIDGE



Stunning three bed, two bath (one en suite - upgraded Spring 2018) duplex apartment for sale or rent, and available furnished, or unfurnished). The property is situated on one of the most sought-after developments in the area (and enjoys a well-managed community with beautiful pool and sun bathing terrace), and comprises open plan lounge/diner, brand new American-style kitchen (Nov 18), four terraces, two having wonderful views over Amarilla golf course up to Mount Teide. There is direct lift access to the apartment and a private garage.

This is a beautiful home, well worth viewing to appreciate what it has to offer!

Ref No: 03-1372

€289,950



Tel: 922 703 725 / 627 230 360

Email: carolhale.tpp@gmail.com • Web: www.tenerifeproperty.com

OPPORTUNITY NOT TO BE MISSED - MASSIVE PRICE REDUCTION



**Price
REDUCED!**

TOWNHOUSE

Amarilla Golf

Ref: ADOV0102

Large semi-detached house with four bedrooms, three bathrooms and private pool. Very quiet area surrounded by greenery, situated near the port of 'Amarilla Golf'

PRICE WAS: 420.000 €

REDUCED TO: 359.000 €



PLAYA PARAISO

Res. SOL PARAISO

Ref: APTV0311

Modern, spacious, part-furnished 3 bed, 2 bath (1 en suite) apartment in sought after sea front complex with 2 pools adjacent to the Hard Rock Café. The property has a lounge/dining area, American-style fitted kitchen, two sunny terraces, each with sea views and located close to all amenities.



310.000 €



VYM CANARIAS – December 19

Luxury Villa in Jardines del Duque



Prestigious area, 2 floors with living area, separate kitchen, bathroom, hall, 3 bedrooms with bathrooms, terraces, balconies, basement with dining area and cellar. Living area 300m2.

€1,650,000

Ref: VS6014D

Habitats del Duque, Costa Adeje



Luxury villa with exquisite design in the prestigious area of El Duque only 200 meters from the beach. Private pool, terrace, garden, 5 bedrooms, kitchen, living rooms, garage for 2 cars.

€1,625,000

Ref: VS6376DN

Apartment, Puerto de Santiago

PROMOTION!

New apartments with 1 bedroom, bathroom, living room with kitchen and great terrace. Garage.

FROM €155,000 Ref: VS6649BS

Townhouse, Puerto de Santiago

PROMOTION!

New Townhouses with 2, 3 and 4 bedrooms, bathrooms, living room, independent kitchen, garage. Ocean view

FROM €245,000 Ref: VS6650/1/2BS

Villa in Sunbay Villas, Amarilla Golf

REDUCED!

4 beds, 3 baths, guest toilet, kitchen and large living room leading to a terrace and garden with a private pool overlooking the ocean. This property comes with a garage space in an excellent location. Living area of 191m2 on a total plot of 536m2.

€430,000 Ref: VS5127D

Ocean Garden, Playa Paraiso

Luxury apartment in new complex with 2 bedrooms, 2 bathrooms, parking space and beautiful terrace. Living area 65m2, terrace 13m2. Pool in the complex.

€270,000 Ref: VS5571D

Villas Canarias, Torviscas Alto

REDUCED!

Fully reformed 1 bedroom apartment with fantastic ocean view. Living area 63m2, terrace 20m2. Complex with swimming pool. Great location near with the commercial center.

€189,000 Ref: VS6225D

El Cortijo, Las Americas

REDUCED!

Bungalow with 1 bedroom, bathroom, living room and kitchen. Living area 55m2. Pool and parking in the complex. Ideal investment.

€189,000 Ref: VS6467D

Los Cristianos, Edf. Ceyla

OPPORTUNITY!

Nice apartment in the heart of Los Cristianos, 2 bedrooms, bathroom, open plan kitchen and living room leading to a terrace. Ideal location walking distance from the beach, restaurants, bars, shops and other services Total plot of 64m2.

€215,000 Ref: VS5562D

Cristimar, Los Cristianos

Three bedroom apartment just 100 meters from the beach. Separate kitchen, 2 bathrooms, living room, balcony. Large pool in the complex, elevator.

€240,000 Ref: VS6667DN

Mirador del Sur, Playa Paraiso

OPPORTUNITY!

First line. Apartment with 1 bedroom, 1 bathroom, living room with kitchen. Complex with the pool. Great location.

€145,000 Ref: VS5275D

Oasis Tropical, Callao Salvaje

REDUCED!

Apartment with 2 double bedrooms with fitted wardrobes, 2 bathrooms, living room and fully fitted kitchen, dining space. Living area 76m2, garden 20m2. Heated pool in the complex.

€220,000 Ref: VS6421DE

Principal Office: C.C. Victoria Tenerife Sur, Local 1, C/ Republica de Panama, 1, LAS AMERICAS, 38660, Adeje



Tel: 922 787 210 / 635 881 888

Email: info@vymcanarias.com · Web: www.tenerifecenter.com

Playa Paraiso: 922 713 395, email: playaparaiso@vymcanarias.com
 Callao Salvaje: 922 717 663, email: callaosalvaje@vymcanarias.com
 San Eugenio: 922 715 185, email: saneugenio@vymcanarias.com
 Golf del Sur: 922 455 874, email: golfdelsur@vymcanarias.com

Residential Property Sales

Over €350,000

Tijoco Bajo, Villa

€985,000
Beautiful, architect-designed villa. Located on one of the best plots of Tijoco Bajo (only 230 m asl) in southern Tenerife. Very private situated on 12,300 m² of land surrounded by Mediterranean gardens full of beautiful trees and plants. A generous (heated) pool and great view of the ocean, the islands of La Gomera and La Palma and El Teide. The living ar... For full information see website or contact:
2nd Home Tenerife Ref: ROA4064 628 608 469

San Eugenio Alto, Villa

€890,000
♦ Location: Quiet location, Close to the coast, Close to the beach, Close to amenities, Central ♦ Close to: Town, Shops, Restaurants / Bars / Cafes, Medical Facilities, Port, Coast, Beach ♦ Views: Teide, Sea, Pool, Mountain, La Gomera, Harbour, Garden ♦ Rooms: Office, Family Bathroom, Ensuite, Fitted wardrobes, Basement, Kitchen diner, Dining room, Indepe... For full information see website or contact:
Property Alliance SL Ref: 5V3357 922 77747

Chayofa, Villa

€860,000
We offer for sale this new villa 409m² is in Chayofa, Arona. It is a villa that has 263 m² living space divided in three rooms and two bathrooms en suite. It is outdoor and villa property. It has a swimming pool, private garden, private garage, a furnished kitchen and its own private terrace with sea view.
FRINA Tenerife SL - Property Sales Ref: S 1108922 085 191

Torviscas Alto, Villa

€845,000
♦ Location: Residential Area ♦ Views: Sea, Mountain ♦ Rooms: Hall / Entrance, Independent Kitchen, Lounge and dining area, Fitted wardrobes, Family Bathroom, Games room ♦ Quality: Quality construction, Furnished, Well presented, Spacious accommodation, Rustic style ♦ Features: Private swimming pool, Jacuzzi, Satellite system ♦ Outside: Sunny Terrace, Large... For full information see website or contact:
Property Alliance SL Ref: 4V3135 922 77747

Alcala, Rural

€750,000
This Finca with villa is situated in the south /east of Tenerife. Near a small tranquil village with fabulous views of the sea and La Gomera 2 storey house, main living area with 3 bedrooms 2 bathrooms, plus a separate granny flat with 1 bedroom. Large garage with workshop and Much more.
Dr Stange International Ref: 86-372

San Eugenio Alto, Villa

€600,000
♦ Location: Residential Area, Quiet location ♦ Views: Sea, La Gomera ♦ Rooms: Utility room, Fitted wardrobes, Lounge and dining area, Independent Kitchen, Hall / Entrance ♦ Quality: Spacious, Rustic style, Good condition, Furnished ♦ Features: Security shutters, Security system, Satellite system, Private swimming pool, Heated swimming pool, Air conditioni... For full information see website or contact:
Property Alliance SL Ref: 5V3128 922 77747

El Roque, Finca

€599,950
3 bedroom finca with courtyard pool and hot tub. There is a driveway and large car parking area. The property has a separate 1 bedroom annex with its own entrance and drive. There are five gardens with many varieties of fruit trees. All of the land is usable.
Palm Mar Sales and Rentals Ref: PMSR0027677-623713 / 671-129558

Golf del Sur, Alamos Park

€599,000
Amazing property situated in one of the most exclusive residential areas of Golf del Sur, comprising of a large

€509,000

We offer for sale this villa 379 m² in the residential area of El Galeon in the complex La Capitana, Adeje. The villa consists of four bedrooms, two bathrooms, a toilet, a kitchen, living room, dining room and balcony overlooking the sea. There is a large terrace that surrounds the entire villa. In addition, there is a private- and community swimming po... For full information see website or contact:
FRINA Tenerife SL - Property Sales Ref: S 1074922 085 191

San Miguel, Townhouse

€500,000
For sale a gorgeous townhouse in a posh location next to a natural park

Piano Lessons

Learn at your own pace with a relaxed, friendly teacher to guide and support you.

Custom made lessons to suit all levels and musical interests.

I am experienced in preparing students for ABRSM Piano Exams.

Call Louise 686 014 355
www.pianointenerife.eu

KEYBOARDS FOR HIRE

detached villa, lush gardens, terrace, indoor swimming pool and garage facilities. The living area consists of 3 bedrooms (one is currently used as a study), 3 bathrooms (the main one with sauna), separate fitted kitchen, lounge, sitting room. T... For full information see website or contact:
Tenerife Alizes Properties Ref: KV0160 922 738653 / 626 274040

Torviscas Alto, Mirador del Sur I

€550,000
♦ Location: Popular urbanisation, Touristic Area, Quiet location ♦ Close to: Restaurants / Bars / Cafes ♦ Views: Sea, Teide ♦ Rooms: Independent Kitchen, Lounge and dining area, Fitted wardrobes, Store rooms ♦ Quality: Furnished, Charming property, Immaculate condition, Well presented, Spacious, Quality residence ♦ Features: Water purification system, Sun... For full information see website or contact:
Property Alliance SL Ref: 3V3386 922 77747

San Eugenio Alto, Villa

€520,000
♦ Location: Quiet location, Touristic Area ♦ Close to: Medical Facilities, Restaurants / Bars / Cafes, Transport, Beach ♦ Views: Mountain, Sea ♦ Rooms: Hall / Entrance, Independent Kitchen, Second Kitchen, Lounge and dining area, Fitted wardrobes, Bathroom, Shower room, Utility room ♦ Quality: Furnished, Spacious accommodation ♦ Features: Private swimming ... For full information see website or contact:
Property Alliance SL Ref: 5V3031 922 77747

Buzanada, Villa

€519,000
We offer for sale this luxurious villa on two floors located in Buzanada, the house of about 400 m² built on a plot of 1000 m². The first floor comprises two bedrooms, a living room combined with kitchen, a bathroom and a large garage for two to three cars. The second floor consists of three bedrooms with two bathrooms, a living room, a living room with... For full information see website or contact:
FRINA Tenerife SL - Property Sales Ref: S 1070922 085 191

El Galeon, Villas La Capitana

with moon landscapes on the one hand, and near the ocean on the other. Also nearby is the city of Los Abrigos on the one hand and Golf del Sur on the other. The house has 2 floors and includes: a separate kitchen with furniture (natural pine) and electrical appliances (Bosch), a spaci... For full information see website or contact:
Vym Canarias Ref: VS5580D 922 787210 / 635 881888

San Eugenio Alto, Detached House

€490,000
3-storey detached house in the upper part of Las Americas (San Eugenio Alto).Upper floor: main apartment with 2 beds, 2 baths and terraces. Groundfloor: 1- bed guest apartment. Basement: large garage/workshop, office and toilet. All bedrooms with aircon. Resort with community pool. This nice property is completely renovated and will be sold part furnish... For full information see website or contact:
Dr Stange International Ref: 85-308 922 793271 / 649 957267

San Miguel, Apartment

€480,000
Block of 6 apartments of 2 rooms each with its garage located in Las Chafiras
Vym Canarias Ref: 1180 922 787210 / 635 881888

Palm Mar, Bahia de Los Menceyes

€475,000
This spacious 2-bedroom apartment on the first floor in the exclusive and luxurious complex Bahia de los Menceyes offers guaranteed amazing ocean views and also panoramic views over the Nature Reserve La Rasca. It is in perfect condition and furnished with quality furniture and also has a fully equipped Italian kitchen with first class appliances. Both be... For full information see website or contact:
FRINA Tenerife SL - Property Sales Ref: S 1009922 085 191

Los Cristianos, Duplex Penthouse

€473,000
Tenerife-South: Duplex-Penthouse in Top-Location of Los Cristianos with Grandiose Roof-Deck and Breathtaking Views --- 168 sqm of living space, thereof 60 sqm of roof-

deck, main terrace 18 sqm, spacious kitchen, 2 BR, 2 bathrooms, garage and trastero, 2 pools (one heated during wintertime, fully furnished, air condition.

A1 Real Estate & Property Consultants Ref: 20150598922 729395 / 655 012711

Valle de San Lorenzo, Villa

€449,750
♦ Location: Rural Location, Quiet location, Central ♦ Close to: Transport, Town, Shops, Schools, Restaurants / Bars / Cafes, Medical Facilities ♦ Views: Teide, Sea, Mountain, Garden ♦ Rooms: Wine cellar, Family Bathroom, Ensuite, Basement, Lounge and dining area, Dining room, Independent Kitchen, Store rooms, Hall / Entrance ♦ Quality: Part furnished, Spa... For full information see website or contact:
Property Alliance SL Ref: 7V3360 922 77747

Los Menores, Villa

€449,000
Adeje: Fancy Villa with 4 Bedrooms, Separate Apartment and Pool in Scenic Location of Los Menores
A1 Real Estate & Property Consultants Ref: 20151199922 729395 / 655 012711

Chayofa, House

€425,000
Chayofa: Charming Villa with 3 Bedrooms, large Sundeck and Sea View Details: Insulating Glass Barbecue Satellite TV Seaview Mansion District Sunny Situation about 100 sqm of Terraces (partly covered) 2 Parking Spaces
A1 Real Estate & Property Consultants Ref: 20150399922 729395 / 655 012711

Playa Paraiso, Parque Paraiso Villas

€425,000
♦ Location: Residential Area, Quiet location, Close to the beach ♦ Close to: Transport, Restaurants / Bars / Cafes, Beach ♦ Views: Sea, Teide, Mountain ♦ Rooms: W.C., Fitted wardrobes, Lounge and dining area, Independent Kitchen, Store rooms, Hall / Entrance ♦ Quality: Quality residence, Spacious, Well presented, Immaculate condition, Furnished, Quality c... For full information see website or contact:
Property Alliance SL Ref: 3TH3093 922 77747

Valle de San Lorenzo, Villa

€420,000
Location - Close to schools - Quiet location Views - Sea - Mountain Additional - Viewing recommended

Interested in advertising with The TPG?

Call us on 922 703 725

Rooms - American style kitchen - Walk in wardrobe Quality - Good condition - Quality construction - Well presented - Bright Features - Trees - Air conditioning - Private swimming pool Outside - Bbq area - Large balcony
Island Estates Ref: 433-V3 922 790767 / 670 605414

Palm Mar, Club de Mar

€410,000

<p>Three bedroom, two bedroom townhouse. Very spacious and set on three floors. The master has it's own floor and en suite bathroom. There are a further two bedrooms and a bathroom on the top floor where there is access to the roof terrace with sea views.</p><p>There is a well equipped kitchen and mezzanine dining area as well as a cloak... For full information see website or contact:

Palm Mar Sales and Rentals Ref: PMSR0065677-623713 / 671-129558

Playa Paraiso, Brisas del Mar

€404,250
♦ Location: Residential Area, Quiet location, Gated community, Close to amenities, Close to the beach ♦ Close to: Transport, Restaurants / Bars / Cafes, Medical Facilities ♦ Views: Sea ♦ Rooms: Store rooms, Utility room, W.C., Family Bathroom, Bathroom, Ensuite, Fitted wardrobes, Lounge and dining area, Independent Kitchen, Hall / Entrance ♦ Quality: Spac... For full information see website or contact:
Property Alliance SL Ref: 2V3086 922 77747

La Caleta, Magnolia Golf Resort

€402,791
This lovely ground floor apartment with 3 bedrooms and 2 complete bathrooms is situated in a lovely complex in the picturesque fishing village of La Caleta, surrounded by a nature reserve and only 300 metres from the sea. A garage and a store room are included in the price. The complex also has a spa, gymnasium, swimming pool and sauna as well as a puttin... For full information see website or contact:

2nd Home Tenerife Ref: NC3000 628 608 469

Roque del Conde, Roque del Conde I

€399,000
We offer for sale this well presented, duplex style apartment with 391m² in Roque del Conde. The beautiful property is constructed over two levels with four double bedrooms, two bathrooms, one of which is an ensuite, an open plan lounge with dining area, kitchen and leading to a very large, partly covered terrace space of 245m² with wonderful views to th... For full information see website or contact:

FRINA Tenerife SL - Property Sales Ref: S 1103922 085 191

Las Americas, Penthouse

€399,000
We offer for sale this three bedroom penthouse with 111m² in the

Sales Ref: S 1075922 085 191

Charco del Pino, House

€395,000
REDUCED. Astonishing house completely renovated with quality materials. It has various ground floor terraces, a garden and a private swimming pool. The 3 bedrooms are spacious and the view is magnificent from the whole house. Very nice furniture...this house is a dream!!
Tenerifehome.com Ref: 510-0311 922 783066

Granadilla, Rural Property

€395,000
Beautiful house with private pool, in excellent condition. The house measures 192 sqm and is built on a plot of 1500 sqm ... located in a very quiet area, the house has beautiful, large garden with lots of plants and fruit trees, offering a wonderful view of the sea and Teide.Important to know, the house is prepared to make a hotel for dogs and cats. Ther... For full information see website or contact:

Tenerifehome.com Ref: 1469-0219 922 783066

La Caleta, Magnolia Golf Resort

€392,828
This lovely ground floor apartment with 3 bedrooms and 2 complete bathrooms is situated in a lovely complex in the picturesque fishing village of La Caleta, surrounded by a nature reserve and only 300 metres from the sea. A garage and a store room are included in the price. The complex also has a spa, gymnasium, swimming pool and sauna as well as a puttin... For full information see website or contact:

2nd Home Tenerife Ref: NC3002 628 608 469

Playa Paraiso, Detached House

€390,000
We offer for sale this spacious 380m² house in Playa Paraiso. The living area consists of 170m² and comprises three double bedrooms, two bathrooms, one guest cloakroom, a kitchen with dining area and a living room. The house is partly furnished. The house offers a large covered terrace from where you can enjoy the beautiful garden or your private swimmi... For full information see website or contact:

FRINA Tenerife SL - Property Sales Ref: S 1044922 085 191

Chio, Rural Property

€390,000
We have a wonderful investment opportunity for someone dreaming of owning a rural property in the south of Tenerife. Located in the charming village of Chio, Guia de Isora sits this seven bedroom property divided into two buildings, in the main house there are six spacious bedrooms, two bathrooms, kitchen and a large living, dining area. The smaller ind... For full information see website or contact:
FRINA Tenerife SL - Property Sales Ref: S 1054922 085 191

Golf del Sur, Townhouse

€385,000
Spacious three bedroom house in Residencial San Blas. There are two bathrooms, one en suite and a cloakroom downstairs. Part of a small phase of only 16 houses with both sea and mountain views. The property is fully furnished and benefits from aire conditioning throughout. There is a large garage with useful storeroom accessed directly from the house.... For full information see website or contact:
Palm Mar Sales and Rentals Ref:



WE HAVE MOVED

C.C. Rio Center, local 6A
TORVICAS BAJO (near the old Sky Park)
 ☎ 922 713 116
 ☎ 692 146 808 / 670 801 154
 Web: www.tenerife-belfin-property.com
 Email: info@tenerife-belfin-property.com

Find us:



EL MADROÑAL

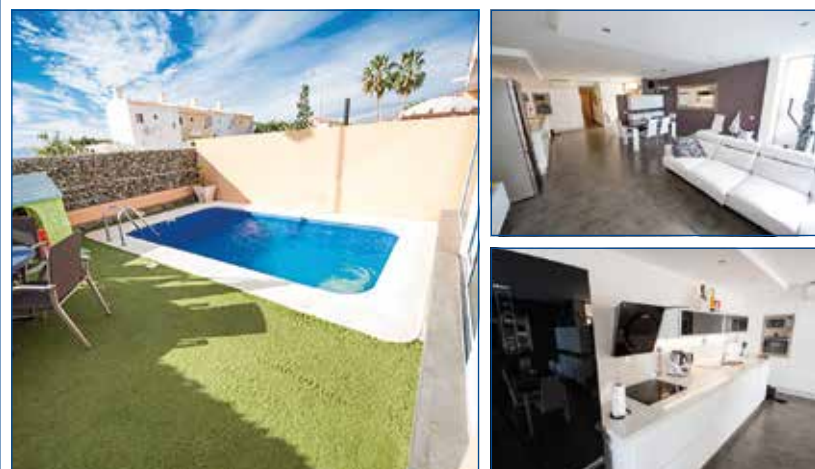

Fantastic modern style 4 bed, 3 bath (1 en suite) villa with private pool, large (50sqm) lounge/kitchen area, and private garden. There is parking and storeroom. Air conditioning. A great family home in a sought-after residential area, very close to all services and shops and only a short drive from the sea front.

€499,000

Ref: V418-BP

VALLE SAN LORENZO



This is a large two-family house, with the upstairs and downstairs separate entities. Our property is the downstairs part, a 2 bed, 3 bath apartment with large lounge, kitchen and rear garden, plus 2 separate studios.

€149,000

VH103-BP

LAS AMERICAS, OLYMPIA



Excellent, refurbished, and fully furnished studio in popular complex with pool, close to the beach and all amenities. The property, in a great location, has a lovely sunny balcony with sea views.

€155,000

ST112-HP

FANABE, SOL SUN BEACH



Very nice, fully furnished and equipped top floor studio apartment with sea views in sought after sea front complex with pool. Everything you need for a holiday apartment with the beach and all services on your doorstep!

€185,000

ST111-HP

MAREVERDE



Unfurnished 1 bed, 1 bath apt. on popular complex with pool in a great location. The property has been refurbished and is just a short walk to the beach.

€142,000

AP107-HP

PLAYA DE LA ARENA



Stunning, fully furnished and equipped to a high standard, 3 bed, 2 bath apartment (105sqm living space/70sqm terraces), all on one floor. Terrace with landscaped gardens and sea views! Complex with pool. Garage and storeroom incl.

€299,000

AP305-BP

GOLF DEL SUR, ALAMOS PARK



Recently completed 7 bed, 5 bath (4 en suite) villa (252sqm built on plot of 1,000sqm) with own pool. The property spans 2 floors with lounge/dining area, feature fitted kitchen, and sun terrace with panoramic views. Great potential!

€695,000

V425-BP

LA MARETA (NEAR EL MEDANO)



Luxury, fully furnished 3 bed, 2 bath corner townhouse in a small seafront complex. Lovely tranquil location by one of the best beaches of Tenerife. Many extras, including a Jacuzzi and a mini-gym.

€339,000

TH305-AG

ROQUE DEL CONDE



Lovely, spacious, 2 bed, 2 bath (1 en suite) townhouse in lovely residential complex with pool. The property has 2 good-size terraces with sea views and a private, closed garage.

€265,000

TH205-HP

ADEJE, LAS MORADITAS



Gorgeous 3 bed, 3 bath (all en suite) villa with own pool on a 5,000sqm plot with beautiful gardens. Upstairs is a spacious lounge/dining area, large kitchen and several terraces offering breath-taking sea and coastal views.

€1,300,000

V423-BP

PLAYA DE LA ARENA



Fantastic, fully furnished, 3 bed, 2 bath (1 en suite) bungalow-style property in complex with pool on the west coast of Tenerife. The property has a lounge, independent fully fitted kitchen, 40sqm terrace.

€299,000

AP305-BP

EL HIERRO, UNIQUE VILLA



Fully furnished, 3 bed, 2 bath villa on 5,500sqm plot right on the sea front! The property has a spacious lounge/diner, fully equipped kitchen, various huge terraces with beautiful sea views, BBQ, sauna, gardens, garage and much, much more!

€398,000

V411-BP

PMSR0001677-623713 / 671-129558

La Caleta, Magnolia Golf Resort €379,331

This lovely first floor duplex apartment with 2 bedrooms, 2 complete bathrooms and a guest toilet is situated in a lovely complex in the picturesque fishing village of La Caleta, surrounded by a nature reserve and only 300 metres from the sea. A garage and a store room are included in the price. The complex also has a spa, gymnasium, swimming pool and sa... For full information see website or contact: **2nd Home Tenerife Ref: NC2042 628 608 469**

Los Menores, Barrio Los Menores €379,000

Beautiful, fully furnished, 3 bedroom, 2 bathroom (1 en suite) home with lovely garden and private pool! Lounge/diner, separate kitchen, and 61sqm roof terrace with amazing views! Private parking spot just in front of the house. Don't miss this opportunity! **Tenerifehome.com Ref: 1121-1115 922 783066**

La Caleta, Magnolia Golf Resort €376,973

This lovely first floor duplex apartment with 2 bedrooms, 2 complete bathrooms and a guest toilet is situated in a lovely complex in the picturesque fishing village of La Caleta, surrounded by a nature reserve and only 300 metres from the sea. A garage and a store room are included in the price. The complex also has a spa, gymnasium, swimming pool and sa... For full information see website or contact: **2nd Home Tenerife Ref: NC2024 628 608 469**

Torviscas Alto, House €375,000

With the opening of CC Gran Sur, Torviscas Alto has now become one of the most attractive areas, just outside Las Americas. Resid. complex with lovely pool area* Bung. with 2 bedroom and 2 bathrooms (1 ensuite)*Sun all day *Unique views of Las Americas, Atl. and La Gomera. This beautiful property will be sold furnished with garage space and store room... For full information see website or contact:

Dr Stange International Ref: 85-306 922 793271 / 649 957267

La Caleta, Magnolia Golf Resort

Las Americas, Parque Santiago III €370,000

Fantastic attic apartment of 48 m2 interior and 9m2 terrace in beautiful complex Parque Santiago III, Las Americas, overlooking the pool and the sea. It consists of 1 bedroom, 1 bathroom, american style open kitchen, living room, terrace. Canarian style complex located directly on the seashore with heated pool. Nearby are bars, restaurants, Aqualand for t... For full information see website or contact:

FRINA Tenerife SL - Property Sales Ref: S 1021922 085 191

Playa Paraiso, Ocean Garden €367,500

We offer for sale this spacious 100m2 apartment in the complex Ocean Garden in Playa Paraiso. The property is in very good condition and newly renovated (2019). The apartment has 85m2 and is located on the fifth floor. It comprises three double bedrooms, two bathrooms, an open American style kitchen and a living room with direct access to the balcony of... For full information see website or contact:

FRINA Tenerife SL - Property Sales Ref: S 1045922 085 191

Acojeja, Detached House €357,000

We offer for sale this completely

renovated and spacious 740m2 house in Acojeja, Guia de Isora. The living space is 278m2 divided into three floors which comprise five bedrooms, three bathrooms, two kitchens, two lounges and four terraces of 200m2 from where you have almost 360 degrees of sea and mountain view. There are three separate entrances to the h... For full information see website or contact:

FRINA Tenerife SL - Property Sales Ref: D 1077922 085 191

Santiago del Teide, Apartment €350,000

We are pleased to offer this fantastic apartment for sale in Playa la Arena!

FRINA Tenerife

business & property agent

+34 670 636 004 · +34 617 294 803

Calle Colón, 1st Floor, local 213, Puerto Colón, 38660 Adeje

tenerifebusinessforsale.com · tenerife-property.com

English, Spanish, Dutch, Flemish, German, French, Danish

visit us here

Including two bedrooms, additional room on the first floor with solarium, three bathrooms, independent kitchen and spacious living room leading to a terrace of 40m2 overlooking the ocean and beyond. This property is sold furnished, all the rooms have air conditioning, there solar ... For full information see website or contact:

Vym Canarias Ref: VS4188 922 787210 / 635 881888

Costa del Silencio, Los Azahares €350,000

For sale that three-story, fully furnished townhouse located in Costa del Silencio in the urbanization Los Azahares. The house has an interior area of 160m2 distributed as follows: Main floor: independent and equipped kitchen, living room, a toilet, a 20 m2 glazed terrace. Upper floor: distributed in two spacious rooms, a bathroom and two balconies of ... For full information see website or contact:

FRINA Tenerife SL - Property Sales Ref: S 1120922 085 191

€349,999 - €250,000

Torviscas Bajo, Santa Maria del Mar €349,950

◆ Location: Central, Close to amenities, Close to the beach, Close to the coast, Touristic Area, Close to the Harbour ◆ Close to: Beach, Coast, Harbour, Medical Facilities, Restaurants / Bars / Cafes, Shops, Town, Transport ◆ Views: Sea, Pool, La Gomera ◆ Rooms: Hall / Entrance, American Style Kitchen, Bathroom ◆ Quality: Furnished, Spacious accommodation ... For full information see website or contact:

Property Alliance SL Ref: 2A3356 922 777747

Torviscas Alto, Las Mimosas €345,000

◆ Location: Residential Area, Popular urbanisation, Close to amenities ◆ Close to: Transport, Schools, Restaurants / Bars / Cafes ◆ Views: La Gomera, Sea ◆ Rooms: Fitted wardrobes, Office, Open plan kitchen, Utility room, Hall / Entrance ◆ Quality: Renovation needed, Cosmetic work needed, Unfurnished ◆ Outside: Covered Terrace, Sunny Terrace ◆ Parking: EL... For full information see website or contact:

Property Alliance SL Ref: 3V3273 922 777747

Las Americas, Optimist €340,000

We offer for sale this spacious 84m2 apartment in the complex Optimist, Las Americas. The property is in very good condition and renovated. It has 78m2 and comprises two double bedrooms, one bathroom, a

kitchen with a living room and dining room and direct access to the balcony of 6m2. The kitchen is sold fully equipped and the furniture is included. T... For full information see website or contact:

FRINA Tenerife SL - Property Sales Ref: S 1049922 085 191

Palm Mar, Paraiso del Palm Mar €340,000

We offer for sale this apartment 85 m2 in the complex Paraiso del Palm-Mar, Palm-Mar. The apartment consists of two floors with two bedrooms, two bathrooms, a big terrace of 44m2 plus garden of 13m2. There is also a solarium of

41m2 and there is a parking space. The community fee is 80 per month. **FRINA Tenerife SL - Property Sales Ref: S 1116922 085 191**

Palm Mar, Duplex €340,000

Beautiful apartment with lots of light, four different terraces and panoramic sea views. This duplex apartment has 2 bedrooms on the ground floor with fitted wardrobes and both with large sliding windows with access to the terrace located next to the pool. The bathroom on this floor has a bath, toilet and bidet.

FRINA Tenerife SL - Property Sales Ref: S 1034922 085 191

Tejina de Guia, House €330,000

Fully furnished 3 bed, 1 bath villa with sea view. The property measures: Int. 205sqm., Ext. 116sqm.

Property Alliance SL Ref: 3V2477 922 777747

Las Americas, Apartment €321,000

Parque Santiago III has been built in 1987 /1988 and is situated in front of a beach. It is one of the most prestigious holiday apt. complexes in the south of Tenerife. Unique pool (2000 m2 !!), sunbathing area, immaculate garden flora/ fauna and rest./ pool bar on site. Apt. on the ground floor (one level) *Sun in the morning, large terrace and garden ... For full information see website or contact:

Currencies Direct

Call Donna in our Los Cristianos office
+34-922 971 781 or Carol on +34-687 906 607

Dr Stange International Ref: 82-739 922 793271 / 649 957267

Palm Mar, Bahia de Los Menceyes €320,000

This spacious one-bedroom apartment on the first floor in the exclusive and luxurious complex Bahia de los Menceyes offers guaranteed amazing ocean views and also panoramic views over the coastline of Playa de las Americas and Los Cristianos as well as the neighbouring island La Gomera. It is in perfect condition and furnished with quality furniture and a... For full information see website or contact: **FRINA Tenerife SL - Property Sales Ref: S 1118922 085 191**

Santiago del Teide, Townhouse €319,000

Townhouse in Santiago del Teide area Playa de La Arena, Euro House. In total they are 150 m2 of surface, 80 m2 of terrace. It consists of 3 double bedrooms, 2 bathrooms, 1 wc. Property is in perfect condition, fully equipped kitchen. The house has a garage for 2 cars. The complex has a communal pool.

FRINA Tenerife SL - Property Sales Ref: S 1003922 085 191

Callao Salvaje, Sueno Azul €310,000

We offer for sale this spacious three bedroom apartment in the complex Sueno Azul, Callao Salvaje. The apartment offers a very generous 300m2 of living, outside space and comprises three bedrooms, two bathrooms (one en-suite), a kitchen with dining and living area adjoining to a very large covered terrace and garden area with sufficient space for a priva... For full information see website or contact:

FRINA Tenerife SL - Property Sales Ref: D 1068922 085 191

Palm Mar, Bahia de Los Menceyes El Madronal, Townhouse €305,000

We offer for sale this three bedroom spectacular townhouse located in Costa Adeje in the district of El Madronal. It is built in 2007, has 169 m2 of which 121 m2 are useful. On the first floor there are three bedrooms, three bathrooms, separate kitchen, living room and two storage rooms. Garage for two cars of 41 m2. It has a terrace of 27 m2 and a smal... For full information see website or contact:

FRINA Tenerife SL - Property Sales Ref: S 1081922 085 191

Los Menores, Detached House €299,000

For sale a detached house located in Los Menores, Adeje. The house is located on a plot of 222m2 and has a total constructed area of 98m2. Distributed as follows: Ground floor: An independent kitchen, living room, toilet, utility room and garden. Upstairs: Three bedrooms, two bathrooms and a balcony. The house is finished with a roof terrace, with a c... For full information see website or contact:

FRINA Tenerife SL - Property Sales Ref: S 1098922 085 191

Costa del Silencio, Semi-Detached House €295,000

Pretty 3 bed, 2 bath semi-detached house in private urbanization with

Currencies Direct

Call Donna in our Los Cristianos office
+34-922 971 781 or Carol on +34-687 906 607

really nice views. The property is on 2 levels with a large private roof terrace/solarium with lovely views to sea and mountains. The plot is walled and gated with electric sliding gates for private car parking and a tiled driveway leading to a garage/workshop. Large patio with swimming... For full information see website or contact: **Tenerifehome.com Ref: 1139-1215 922 783066**

Costa del Silencio, Villa €295,000

This very well-maintained, detached house, is built on a plot of 369m2. The built area is 125m2. The property consists of 3 large bedrooms, 2 bathrooms, a fully equipped kitchen,

a roof terrace and a garage. Around the house there are several terraces and gardens. The price/quality ratio is optimal!

Tenerifehome.com Ref: 1373-0418 922 783066

Amarilla Golf, Palm Ridge €294,995

Stunning 3 bed, 2 baths (one en suite - upgraded Spring 2018) duplex apartment for sale on Amarilla Golf. (Available furnished/unfurnished). Situated on one of the most sought-after developments in the area. Well-managed community. Beautiful community pool. Apartment comprises open plan lounge diner/ kitchen (New kitchen Nov 18), four terraces, two having ... For full information see website or contact: **Tenerife Prime Property Ref: S-03 1372 627-230360**

Los Abrigos, San Blas €289,000

Great opportunity to purchase one of these townhouses for sale on a residential complex with pools, close to the sea, between Los Abrigos and Golf del Sur. The houses have 3 bedrooms, the main one double with ensuite bathroom, and all the bedrooms have built-in wardrobes. Finishings are to high standards and include alarm, air conditioning, electric shutt... For full information see website or contact:

Tenerife Alizes Properties Ref: KV0225 922 738653 / 626 274040

Los Gigantes, Apartment €275,000

Excellent property located in the area with the best climate in Tenerife, Playa La Arena Los Gigantes. It has 2 bedrooms, 2 bathrooms, excellent 30 m2 terrace with partial sea view and facing the pool, there is also a back garden shaded by ivy, fully equipped kitchen, garage space of 14 m2 and storage of 6m2. Built with quality materials: marble floor, d... For full information see website or contact:

FRINA Tenerife SL - Property Sales Ref: S 1010922 085 191

Santiago del Teide, Apartment €269,000

Excelent position both for living and for holidays. The complex is situated in few meters from the coast and the beach Playa la Arena with good touristic. The apartment has 2 spacious bedrooms, 2 bathrooms, independent kitchen, large living room and the terrace of 30m2 with nice views to the ocean and the gardens, there is a private garden of 15m2. A pa... For full information see website or contact:

Vym Canarias Ref: VS4966D 922 787210 / 635 881888

San Miguel, Apartment €265,000

We are more than pleased to offer this stunning penthouse apartment in the most prestigious area of Amarilla Golf - Fairways Club. Comprising two bedrooms, two bathrooms, open plan kitchen with a spacious and luminous living room leading to a terrace overlooking the ocean and golf course. Additionally, the property comes with a large rooftop terrace with ... For full information see website or contact:

Vym Canarias Ref: VS5796D 922 787210 / 635 881888

Los Cristianos, Apartment €265,000

The apartment is newly renovated and comprises two double bedrooms, one bathroom, an open American style kitchen and a living room with direct access to the balcony of 6m2. The kitchen is sold fully equipped and all the furniture is included. There are a communal swimming pool and communal parking. The community fees are 165 pe... For full information see website or contact: **FRINA Tenerife SL - Property Sales**

Ref: S 1051922 085 191

Los Cristianos, Apartment €265,000

Wonderful and newly renovated apartment near the promenade in Los Cristianos. With tennis courts and a nice pool area, this is a very good and well-maintained complex. The apartment has two bedrooms, a bathroom, kitchen and a beautiful view.

FRINA Tenerife SL - Property Sales Ref: S 1029922 085 191

Palm Mar, Paraiso del Palm Mar €265,000

Beautiful duplex penthouse apartment with two bedrooms. Both bedrooms are spacious with built in wardrobes, bathroom with a jacuzzi bath, 1 guest toilet, fully equipped kitchen. This property has several terraces with sea views located in the sunny side. The apartment is sold furnished and with parking included in the price. The property is situated in a f... For full information see website or contact:

2nd Home Tenerife Ref: RP2108 628 608 469

Los Cristianos, Cristian Sur €259,950

We offer for sale a duplex apartment 97m2 in Los Cristianos. The apartment is located on the third floor in the complex Cristian Sur. The ground floor consists of a hall, open-plan kitchen, one bathroom and a terrace of 10m2. The first floor offers two bedrooms, one bathroom and a terrace of 14m2. This property is sold fully furnished. The complex cons... For full information see website or contact:

FRINA Tenerife SL - Property Sales Ref: S 1059922 085 191

San Eugenio Bajo, Apartment €259,000

Tenerife-South: San Eugenio Bajo, Chic 2-Bedroom Apartment, Seafront Location in Club Villamar, Beautiful Pools and Gardens. All inquiries welcome!

A1 Real Estate & Property Consultants Ref: 20141298922 729395 / 655 012711

Chayofa, Bungalow €255,000

Bungalow with 2 bedrooms, 2 bathrooms, living room and kitchen. It has different environments on the outside, with gardens and rest areas. In addition to basement with playground. Located in a very quiet area. Internal surface 100 m2. Exterior 144 m2.

FRINA Tenerife SL - Property Sales Ref: S 1000922 085 191

Playa Paraiso, El Horno €250,000

We offer for sale this beautiful apartment 82 m2 in the complex El Horno, Playa Paraiso. The apartment consists of two double bedrooms, a bathroom, kitchenette with living room and a terrace of 15m2. The property is in good condition and the kitchen is fully equipped. The complex has a communal pool and there is private parking. Community fees are 57 ... For full information see website or contact:

FRINA Tenerife SL - Property Sales Ref: S 1105922 085 191

San Eugenio Bajo, Tinerfe Gardens €250,000

Spacious (76sqm + 35sqm terrace), fully furnished 2 bedroom, 1 bathroom duplex apartment in popular complex with pool and close to beach, harbour and all amenities.

Palm Mar Sales and Rentals Ref: PMSR0032 677-623713 / 671-129558

San Miguel, Villa €250,000

We are very pleased to offer for sale a semi detached house in Las Adelfas II, Golf del Sur. On the ground floor of this well maintained two-storey property you will find a spacious independent kitchen with



Tenerife Properties.ES



info@tenerifeproperties.es www.tenerifeproperties.es

JOY +34 620 253 957

PABLO +34 620 731 368

CATERINA +34 649 851 608

El Duque, Villas del Duque



Beautiful 4 bedroom, 3 bathroom townhouse in this prestigious residential complex. Recently refurbished with high quality materials, with airconditioning throughout.

Price: €610,000 Ref: 13965



Mirador del Golf - Costa Adeje



Beautiful townhouse with two beds and two baths on a residential complex next to Adeje Golf course with stunning views.

Price: €449,000 Ref: 01444

The Sunset, Torviscas Alto



Great Opportunity. 2 bed apartment with stunning views and enclosed garage.

Price: €205,000 Ref: 7651

Santa Maria, Torviscas Playa



Third floor, 1 bed apartment. Large double balcony with sea views. Established complex.

Price: €235,000 Ref: 11248

Playa Paraiso II, Playa Paraiso



Lovely 3 bed, 2 bath duplex apartment on a complex in the heart of town.

Price: €239,000 Ref: 12382

Amarilla Golf, Sun Bay Villas



Lovely, light airy duplex on a plot of 59 duplexes situated on the new development of Sun Bay Villas located on Amarilla Golf

Price: €295,000 Ref: 13333

Fañabe, Lagos de Fañabe



Lovely 2 bed apartment on this prestigious complex with partial sea views. Very close to the beach and all amenities.

Price: €360,000 Ref: 15195

Terrazas del Duque II, Bahía del Duque



Lovely 1 bed, 1 bath apartment in prestigious resort.

Price: €299,000 Ref: 15367

Villas Fañabe, Costa Adeje Duque II



Immaculate 2 bed, 1 bath apartment, for sale fully furnished in this prestigious resort, included with a calendar of reservations.

Price: €435,000 Ref: 14856

Los Girasoles, El Madroñal



Lovely four bedroom villa with private pool in this prestigious area.

Price: €499,000 Ref: 10077

Avda. Ernesto Sarti s/n, Pueblo Torviscas, local M2, COSTA ADEJE 38670

separate utility room, from the kitchen you are into an open lounge dining area with lots of natural sunlight from the double doors which lead to a la... For full information see website or contact:

Vym Canarias Ref: VS53400
922 787210 / 635 881888

€249,999 - €150,000

El Madronal, Mirador del Duque **€249,900**

Spacious (187sqm + 40sqm terrace), fully furnished, 3 bedroom, 3 bathroom duplex in complex with pool. Close to all amenities (Gran Sur, Siam Park, Water Park etc).

Palm Mar Sales and Rentals Ref: PMSR0025677-623713 / 671-129558

Golf del Sur, Winter Gardens **€246,750**

Lovely 2 bedroom, 2 bathroom (1 en suite) apartment on a popular complex on the Golf del Sur. This property is very tastefully furnished and has a separate, fully equipped kitchen with a small utility room, large lounge leading off to a good size terrace and community swimming pool.

El Galeon, House **€245,000**

This elegant townhouse is located in Adeje's trendy district "El Galeon", close to the sport-center and only a short walk from downtown Adeje. The residential complex of "Los Océanos" is fitted perfectly into the light slope, the premises gather around a huge courtyard with beautiful pool, sunbathing area and playground. Across the neat front garden you a... For full information see website or contact:

A1 Real Estate & Property Consultants Ref: 20140997922 729395 / 655 012711

Santa Ursula, Townhouse **€245,000**

Bank property: Townhouse located north, distributed on two floors with area for parking. On the ground floor we find living room, kitchen, utility room and toilet, on the top floor 3 bedrooms and 2 bathrooms, has a garden and terrace area.

Vym Canarias Ref: VS5798BS
922 787210 / 635 881888

Los Cristianos, Yaiza **€240,000**

Centrally located only 30 metres from the beach, Playa de las Vistas. This two bedroom apartment is sold fully furnished and the price includes a garage for two cars and private storeroom.

Palm Mar Sales and Rentals Ref: PMSR0018677-623713 / 671-129558

Santiago del Teide, Apartment **€239,000**

Apartment in the residential complex Playa de la Arena Phase 1. It consists of 2 bedrooms with wardrobes, 2 bathrooms, kitchen, living room with access to the terrace with garden and view to the ocean. There is also a terrace with access from the kitchen. There is parking in the communal garage and 6m2 storage room. Apartment is sold fully furnished, all ... For full information see website or contact:

Vym Canarias Ref: VS5269D
922 787210 / 635 881888

Los Cristianos, Parque Tropical I **€239,000**

We offer for sale this apartment 64 m2 on the ground floor in the complex Parque Tropical, Los Cristianos. The apartment consists of one bedroom, a bathroom, a kitchen, living room and terrace overlooking the communal swimming pool. The apartment is renovated and in very good condition. The community has a swimming pool and elevator. All services are ne... For full information see website or contact:

FRINA Tenerife SL - Property Sales Ref: S 1109922 085 191

Playa de la Arena, Balcon de Los Gigantes **€234,000**

Pleasantly presented apartment 75m2 in the complex of Balcon De Los Gigantes, Puerto de Santiago. Based on the fourth floor, this property comprises two double bedrooms, two bathrooms, one of which is an ensuite, lounge with dining area and kitchen with breakfast bar. Large terrace of 24m2 accessible from both bedrooms and lounge, offering wonderful sea... For full

Interested in advertising with The TPG?

Call us on 922 703 725

information see website or contact:
FRINA Tenerife SL - Property Sales Ref: S 1084922 085 191

Puerto de Santiago, Apartment **€225,000**

We offer for sale this two bedroom apartment of 72m2 in los Gigantes complex, Puerto Santiago. The apartment is located on the third floor and has a large 24 m2 terrace with ocean and cliffs view. The property has access to well designed pool, jacuzzi and solarium area. This apartment has two bedrooms, two bathrooms, an American style kitchen and one li... For full information see website or contact:

FRINA Tenerife SL - Property Sales Ref: S 1052922 085 191

San Miguel, Apartment **€220,500**

Great apartment in the complex Sand Club, Golf del Sur. Including two bedrooms, two bathrooms, large living room with open plan kitchen and dining area. The property has a spacious terrace with breathtaking views over the ocean and swimming pool. At the entrance there is a front yard with a place for storage and a cosy little garden. The complex has two s... For full information see website or contact:

Vym Canarias Ref: VS5281D
922 787210 / 635 881888

San Eugenio Alto, Malibu Park **€220,000**

◆ Location: Close to amenities, Gated community, Popular urbanisation, Touristic Area ◆ Close to: Restaurants / Bars / Cafes ◆ Views: Sea ◆ Rooms: Hall / Entrance, Independent Kitchen, Utility room ◆ Quality: Part furnished, Renovation needed ◆ Features: Security shutters ◆ Outside: Sunny Terrace, Large Terrace ◆ Parking: Street parking ◆ Community facilities... For full information see website or contact:

Property Alliance SL Ref: 2A3266 922 777747

Guimar, Finca **€220,000**

We have for sale Finca in the area of Guimar. The land is divided into "rustic" of 301m2 and "urban" of 448m2, the latter has a built area of 275m2 in different buildings. Property to reform.

FRINA Tenerife SL - Property Sales Ref: S 1004922 085 191

Torviscas Alto, The Sunset **€210,000**

◆ Location: Gated community ◆ Views: La Gomera, Sea ◆ Rooms: Bathroom, American Style Kitchen, Hall / Entrance ◆ Quality: Bright, Furnished ◆ Features: Air conditioning ◆ Outside: Sunny Terrace ◆ Parking: Ample private parking ◆ Community facilities: Heated swimming pool, Gardens ◆

Property Alliance SL Ref: 2A3367

922 777747

San Miguel, Townhouse **€210,000**

Charming townhouse in complex Fairway Village, Amarilla Golf. Comprising two bedrooms, two bathrooms, kitchen and large living room leading to a terrace overlooking the ocean. This property comes with a lovely garden and is situated in the residential complex with swimming pool and bar. Great location of Amarilla Golf, surrounded by golf courses, number o... For full

information see website or contact:
Vym Canarias Ref: VS3843
922 787210 / 635 881888

Las Americas, Los Tajinastes **€205,000**

We offer for sale this penthouse of 40m2 on the 12th floor in the complex Los Tajinastes, Las Americas. The property is renovated and consists of one bedroom, one bathroom with window, kitchenette, living room and a terrace with 14 m2. From the terrace you have nice views to the sea, the mountains, the golf course and the Teide. The furniture is includ... For full information see website or contact:

FRINA Tenerife SL - Property Sales Ref: S 1086922 085 191

Los Cristianos, La Chunga **€199,000**

For sale an apartment in the complex La Chunga, Los Cristianos. The apartment has 55m2 distributed in 1 bedroom, 1 bathroom, living room, equipped kitchen and terrace. Complex with community parking.

FRINA Tenerife SL - Property Sales Ref: S 1024 922 085 191

San Eugenio Alto, Paradise Court **€195,000**

We offer for sale this apartment 51m2 with sea view in the complex Paradise Court, San Eugenio Alto. The apartment consists of one bedroom with window, one bathroom, a kitchenette and a terrace with 10 m2. All furniture is included. There is a heated community swimming pool. Community fees are 90 per month.

FRINA Tenerife SL - Property Sales Ref: S 1089922 085 191

Costa Adeje, Studio **€190,000**

Beautiful studio in the popular tourist area of Costa Adeje in the complex Mareverde, just 10 minutes walk from Fanabe beach. The apartment is sold with furniture, consists of 1 bedroom, 1 bathroom and a living room with open plan kitchen and access to the terrace with views of the ocean and mountains. In the complex there are different swimming pools. C... For full information see website or contact:

FRINA Tenerife SL - Property Sales Ref: S 1005922 085 191

Los Cristianos, Dinastia **€189,000**

Spacious, part-furnished 2 bed, 1 bath apartment (converted from a 1 bed) on popular complex with pools. The property has a lounge/dining area, American style kitchen and 20sqm terrace with fabulous sea views. PROPERTY GREATLY REDUCED FOR QUICK SALE.

Tenerife Prime Property Ref: S-02 1319 627-230360

Las Rosas, Las Rosas **€189,000**

Large 3 double bedrooms, 2

bathrooms (1 en suite) fully furnished apartment being sold on the 2nd floor with lifts through the complex. There is a separate fitted kitchen and utility room, good size lounge and an underground enclosed garage. Low community fees. Nice family home in popular village close to Las Galletas.
Tenerife Prime Property Ref: S-03 1367 627-230360

Los Cristianos, Ceyla **Torviscas Bajo, Orlando** **€181,000**

We offer for sale this apartment 55m2 with spectacular sea views and completely renovated in the complex Orlando, Costa Adeje. The apartment consists of one bedroom with parquet floor, one bathroom, a living room with kitchenette and terrace. The apartment is sold furnished and equipped and is only five minutes walk from Playa de Fanabe, Playa del Duque... For full information see website or contact:

FRINA Tenerife SL - Property Sales Ref: S 1087922 085 191

San Eugenio Alto, Malibu Park **€180,000**

We offer for sale this apartment in the complex Malibu Park, Troviscas Alto. The apartment is made of high standard with a cosy bedroom, elegant bathroom, spacious living room, open plan kitchen and a terrace. The bedroom is an oasis of peace and calm featuring a very comfortable, roomy bed with soft sheets, spacious wardrobe with a mirror and ample li... For full information see website or contact:

FRINA Tenerife SL - Property Sales Ref: D 1095922 085 191

San Eugenio Alto, Malibu Park **€180,000**

We offer for sale this apartment in the complex Malibu Park, Troviscas Alto. The apartment comprises a comfortable bedroom, a bathroom and a spacious living room with an open plan kitchen leading to a lovely terrace. The entire, roomy apartment has been furnished with all the necessary amenities. An open plan kitchen furnished with all the necessary appl... For full information see website or contact:

FRINA Tenerife SL - Property Sales Ref: D 1096922 085 191

Roque del Conde, Apartment **€180,000**

Apartment in a quiet area of Roque del Conde in Torviscas Alto. Apartment of 2 separate bedrooms, 2 bathrooms, fully equipped kitchen, spacious living room and a large terrace with panoramic views of the ocean. The apartment is for sale fully furnished. Price of the apartment includes own parking space and a pantry. The complex features a lovely swimming p... For full information see



website or contact:

2nd Home Tenerife Ref: ROA2100 628 608 469

Los Cristianos, Apartment **€176,000**

A great choice for those who appreciate nice and sunny weather, all year long in one of the most busiest places of the South of Tenerife. On sale, super cozy and beautiful 2 bedroom apartment in Los Cristianos. Totally refurbished and furnished. This apartment consists of 2 bedrooms, 1 bathroom, salon with kitchen and terrace. The total of 52 m2. The compl... For full information

see website or contact:

FRINA Tenerife SL - Property Sales Ref: S 1035922 085 191

Playa Paraiso, Ocean Garden **€176,000**

OCEAN GARDEN. Luxury modern residential complex under construction with 151 apartments! The complex is planned to be finished end 2017. Located in the small tourist village Playa Paraiso which offers a small sandy beach, bars, restaurants and the famous Hard Rock Hotel. Available 1, 2 and 3 bedroom apartments all with good size terraces (the ground floors... For full information see website or contact:

2nd Home Tenerife Ref: OCEAN GARDEN 628 608 469

San Miguel, Apartment **€175,000**

Apartment in the complex Terrazas de la Paz in Golf del Sur. There is 1 bedroom, 1 bathroom, open kitchen with spacious living room and a large terrace of 32m2 with sea view, The apartment is reformed and has lots of outside space. The complex is one of the best in the area and offers 2 swimming pools, one of them is heated, a parking and a bar and is si... For full information see website or contact:

Vym Canarias Ref: VS5284D
922 787210 / 635 881888

Los Gigantes, Club II **€175,000**

We are pleased to present to the market a lovely fully refurbished and newly furnished one bedroom apartment 40m2 on the complex Club II in Los Gigantes. The apartment offers excellent quality materials and design with mirror-effect ceiling. Sold fully furnished with excellent quality furnishings and wood floor effect finish. The kitchen is fully fitted ... For full information see website or contact:

FRINA Tenerife SL - Property Sales Ref: S 1107922 085 191

Los Cristianos, Castle Harbour **€170,000**

Bright and spacious one bedroom 60m2 duplex located on the top floor of the Castle Harbour complex, Los Cristianos. The apartment has two floors: on the ground floor there is a spacious living room with a glazed terrace overlooking the pool and the city, an equipped open kitchen (washing machine, dishwasher, built-in refrigerator) and a bathroom. On the... For full information see website or contact:

FRINA Tenerife SL - Property Sales Ref: S 1079922 085 191

Llano del Camello, La Concepcion **€169,995**

Lovely 2 bed, 2 bath (1 en suite) apartment being sold part furnished

are included. The Parque don José complex is centrally located in Costa del Silencio and offers a fantastic recently renewed swimming pool!
Tenerifehome.com Ref: 1487-0519 922 783066

San Eugenio Alto, Ocean View **€169,000**

Location close to amenities, close to town, quiet location, residential area Views la gomera, sea Additional viewing recommended ... For full information see website or contact:

Island Estates Ref: 221-A1 922 790767 / 670 605414

Chayofa, Apartment **€165,000**

We have for sale beautiful apartment in Chayofa - Urbanization La Finca. The property of 48 square meters of interior is distributed in a room, a living room with fully equipped kitchen (dishwasher, stove, oven, fridge and washing machine), a bathroom and magnificent terrace of 30 square meters. The house has two independent entrances - the second from th... For full information see website or contact:

FRINA Tenerife SL - Property Sales Ref: S 1026922 085 191

Santiago del Teide, Apartment **€165,000**

Nice and modern apartment in the complex Playa de la Arena just in few minutes walk from the beach with the same name. It consists of a living room, kitchen, bedroom, bathroom, terrace overlooking the pool. Living area has 60m2, total area is 71m2. For sale fully furnished, there is airconditioning both in the living room and in the bedroom. The price in... For full information see website or contact:

Vym Canarias Ref: VS5541D
922 787210 / 635 881888

Los Cristianos, Rosamar **€165,000**

We are pleased to offer this bright spacious apartment in the complex Rosamar, Los Cristianos. This is a one bedroom apartment with a living and terrace space of 47m2, comprising one double bedroom, bathroom, American style kitchen, living and dining room leading to the terrace with lovely views.

FRINA Tenerife SL - Property Sales Ref: S 1023922 085 191

San Eugenio Alto, Colina Blanca **€164,000**

◆ Location: Touristic Area, Popular urbanisation, Gated community ◆ Views: La Gomera, Sea ◆ Rooms: Fitted wardrobes, Open plan kitchen ◆ Quality: Tastefully decorated, Refurbished, Renovated, Well presented, Immaculate condition, Furnished ◆ Outside: Large Terrace, Sunny Terrace ◆ Parking: Street parking ◆ Community facilities: Swimming pool, Pool Bar ◆

Property Alliance SL Ref: 1A3246 922 777747

Palm Mar, La Fuente del Palmer **€162,500**

Corner apartment with large terrace, lounge with panoramic mountain view, fully equipped kitchen, bedroom with built in wardrobes and small terrace, full bathroom. Partial sea view from the terrace. La fuente del Palm-mar is a quiet residential complex with large communal pool area and lush green garden areas, situated close to all amenities.

2nd Home Tenerife Ref: RP185 628 608 469

Costa Adeje, Apartment **€161,000**

For sale an apartment in Ocean View, San Eugenio Alto, Adeje. The house has 55m2 of interior and a wonderful terrace of 30m2 with panoramic views of the sea and Playa de Las Americas. It has 1 bedroom, 1 bathroom, living room, american kitchen.

FRINA Tenerife SL - Property Sales Ref: S 1025922 085 191

There is a good size lounge, separate fitted kitchen and 6m2 terrace with views to the community swimming pool. This property is on the 2nd floor with lifts through the complex. Low community fees.

Tenerife Prime Property Ref: S-02 1371 627-230360

Costa del Silencio, Apartment **€169,000**

Cozy 1.5 bedroom apartment of 50m2 with South-East facing terrace of 21m2 overlooking the communal gardens and side to the swimming pool. The property is well maintained and is sold furnished. 2 new blinds

EXCLUSIVE

LUXURY New Development ON AMARILLA GOLF RESERVE WITH JUST €10,000

BUY-OFF-PLAN

EASY PAYMENT OPTIONS AVAILABLE

POOL & JACUZZI OPTIONAL *

Only 9 Properties on this EXCLUSIVE New Development of luxury link detached villas, each one beautifully designed for contemporary living. These fantastic four bedroom properties will be located in a prime position on Amarilla Golf, boasting stunning mountain and golf course views.

Due for completion in the Autumn/Winter of 2021. **THESE PROPERTIES CAN BE RESERVED EXCLUSIVELY AT TENERIFE PROPERTY SHOP**, with a deposit of just €10,000. CHOOSE YOUR PREFERRED POSITION NOW.

These are all **Buy-Off-Plan** properties and prices start from **€390,000!!!**

**FOR MORE INFORMATION CALL TENERIFE PROPERTY SHOP:
0034 922 714 700 / From UK: 0845 862 1634**



9 Luxury Homes

Beautifully designed to suit the needs of contemporary living...



TENERIFE PROPERTY SHOP S.L.

G.I.P.E. NO. 3722



www.tenerifepropertyshop.com



Tenerife Prime Property

Tel: 922 703 725 / 627 230 360

Email: carolhale.tpp@gmail.com

Web: www.tenerifeproperty.com

AMARILLA GOLF, PINEHURST



Beautifully decorated, fully furnished, 2 bed, 1 bath ground floor apartment on popular complex with pool, close to all amenities and the sea front (and the complex pool bar/restaurant!). This spacious (77sqm) property has a lounge/diner, American-style fully fitted kitchen and a large sunny terrace overlooking the pool and gardens. Com. Fees are €306 every two months.

Ref: S-02 1384

Price: £165,000 Sterling

**DO YOU FEEL
CONFIDENT WHEN
BUYING OR SELLING
A PROPERTY?**



We have the largest network of Real Estate Agencies in the South of Tenerife - **32 offices** and more than **150 sales agents** all able to offer your property at the same time!

THE ASSOCIATION COUNTS ON EXPERIENCED LAWYERS AND TAX ADVISERS IN THE SOUTH OF TENERIFE.

IF YOU WOULD LIKE TO BUY, SELL, OR RENT A PROPERTY WITH COMPLETE CONFIDENCE, PLEASE DO NOT HESITATE TO CONTACT ANY OF OUR ASSOCIATION MEMBERS.

CALL US! WE HAVE BUYERS WAITING!

Amulet Property Development Group – 922 083 415
 Atlantic Properties – 922 795 560
 Belfin Property – 692 146 808
 Canarias Global Invest – 609 793 707
 Castle Properties – 922 718 425
 Compas Inmobiliaria – 922 702 504
 DAM Tenerife – 922 788 331
 Gigi Inmobiliaria – 922 734 151
 InmoCarolina 2006 Real Estate – 922 717 389

Karina Properties SL – 922 793 176
 Los Menceyes Properties – 922 732 173
 Paul Ruane-Los Gigantes Properties – 922 861 313
 Melisofi Consulting S.L. – 922 788 125
 Premier Properties Tenerife – 695 822 120
 Property Center Q-Rort Canarias – 607 775 394
 San Eugenio Real Estate – 922 719 941
 Alliance Group Hofman Estates S.L. – 922 777 747

Tenerife Properties for Sale (Belgaten SL) – 607 387 545
 Tenerifehome – 922 783 066
 Tenerife Property Network Int'l – 922 798 320
 Tenerife Property Partners – 922 707 205
 Tropical Country House – 922 719 643
 Tenerife Property Shop – 922 714 700
 Visaverde CSSL – 922 794 214
 Vym Canarias - 922 787 210
 Wady Properties – 922 712 254

TENERIFE SOUTH REAL ESTATE ASSOCIATION

Avda. Antonio Dominguez No 5,
 C.C. ZentralCenter, 5th Floor, Office 2,
 PLAYA DE LAS AMERICAS 38660
 (Asesores: Laynez & Fornies)

INTEGRITY · SECURITY · TRANSPARENCY



TENERIFE PROPERTY SHOP S.L.





Inmobiliaria - Estate Agent

Homes & Away



All the girls at Homes and Away would like to wish everyone a Very Merry Christmas!

+34 922 737 044 info@homesandaway.com
 Local 31, CC San Blas, GOLF DEL SUR, Tenerife www.homesandaway.com

SALES

AMARILLA GOLF



3 bed, 2 bath (1 en suite) villa with covered driveway, swimming pool and large entertainment area. Backing the golf course.

€415,000

CHARCO DEL PINO



Semi-rural detached villa with private pool, roof terrace, entertainment area and secluded garden within Canarian village community.

€350,000

AMARILLA GOLF



Front line to the sea 2 bed, 2 bath duplex with large integral garage, private gardens front and rear and an additional terrace giving stunning pool, marina and sea views.

€290,000

GOLF DEL SUR



Well presented 3 bed, 2 bath villa with garden, 2 terraces (1 with sea view) situated on a sought after residential complex 2 minutes' walk to the sea and all amenities

€299,000

AMARILLA GOLF



Situated in a sought after location, backing the golf course, 4 bed, 3 bath exclusive villa with private pool and entertainment area, close to the sea. Investment opportunity. A must to view!.

€495,000

LLANO DEL CAMELLO



Spacious 3 bed, 2 bath unfurnished apartment with terrace overlooking the pool. Excellent family home.

€149,000

AMARILLA GOLF



3 bed, 2 bath open plan villa with large private pool and driveway situated in popular residential area, close to the sea. Ideal family home

£350,000 Sterling

GOLF DEL SUR



2/3 bed top floor apartment in central San Blas location.

€135,000

AMARILLA GOLF



Immaculate and contemporary top floor 1 bed apartment with 2 terraces overlooking San Miguel Marina.

€229,000

GOLF DEL SUR



Spacious 2 bed, 2 bath apartment with large terrace enjoying lovely views. Close to the pool. The property has lift access and a secure parking space.

£215,000 Sterling

GOLF DEL SUR



Second floor, 1 bed apartment on popular holiday complex overlooking the pool. Good rental investment.

€125,000

AMARILLA GOLF



Well-appointed, spacious 3 bed, 2 bath (1 en suite) detached villa with private pool and garden with beautiful golf and sea views. Driveway with car port.

€420,000

Tenerife Prime Property

Amarilla Golf, Palm Gardens



Lovely, spacious (78sqm + 23sqm total terraces) and beautifully presented, part-furnished 2 bed, 2 bath (master en suite) 1st floor apartment in sought after 'golf course' complex with pool and sunbathing terraces. The property, which enjoys sea and golf course views has a lounge/dining area, independent fitted kitchen, two sunny terraces and a private garage. Extras include: aircon, security grilles and dishwasher



S-02 1391

€239,000

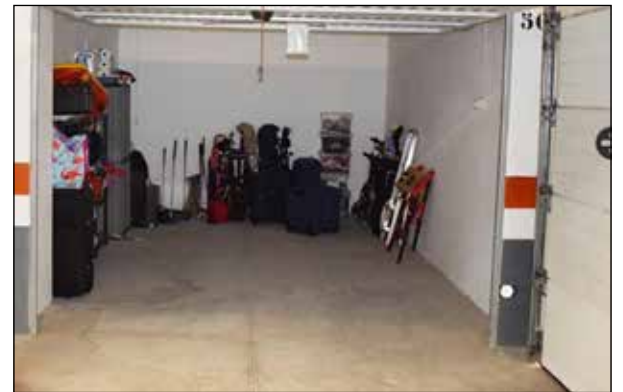
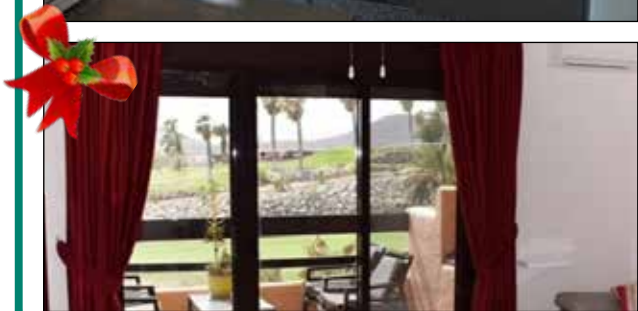

PROPERTIES IN ALL AREAS REQUIRED FOR LONG TERM RENTAL - CLIENTS WAITING!

Buzanada, Edf. Eos



Lovely, fully furnished, 2 bed, 1 bath apartment in a block of only 8 apartments and lift. The property has a lounge-diner, American style fully fitted kitchen, private 70sqm roof terrace with direct access.

S-02 1357

€129,000

Golf del Sur, Green Park



Fully refurbished and furnished 1 bed, 1 bath 3rd floor apartment overlooking the community pool with aircon and newly fitted kitchen. Lifts throughout the complex.

S-01 1343

€99,750

Amarilla Golf, Augusta Park



Beautiful, ground floor 1 bed, 1 bath apartment being sold fully furnished. There is a lounge and fully equipped American style kitchen, A/C, electric shutters and an 8m2 terrace overlooking the community swimming pool.

S-01 1354

£149,000 Sterling

El Medano, Sotavento



Lovely, unfurnished 3 bed, 2 bath, 1st floor duplex apartment on sought after sea front complex with pool and tennis courts. The property has a lounge/diner, open plan kitchen, sunny terrace and a secure parking space/storeroom. Close to amenities.

S-03 1390

€279,500

Fañabe, Lagos de Fañabe

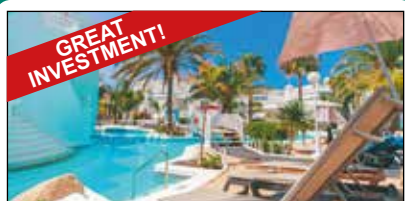

Beautiful, fully furnished 1 bed, 1 bath apartment on sea front, 'Touristic' complex with 3 pools, just 70 metres from the beach. The property has a lounge/diner, open kitchen, sunny terrace and private parking. Holiday occupancy is 60%+ (at c€500/€950 per week).

S-01 1379

€300,000

Los Cristianos, Parque Tropical II

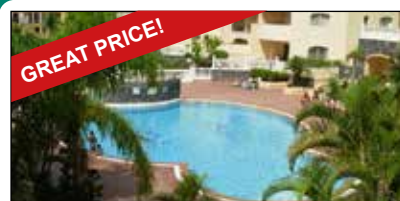

Large, part-furnished, 2 bed, 2 bath duplex apartment in sought after complex with lovely pool area. The property has a lounge/diner, American-style kitchen, small front garden and a large terrace off the lounge overlooking the pool. Needs minor refurbishing.

S-02 1150

€250,000

Torviscas Alto, Los Altos del Roque



Well-presented, fully furnished 1 bed, 1 bath ground floor apartment on popular residential complex with pool and sunbathing terraces. The property, in an elevated position with no one above, has a lounge-diner, open plan kitchen, a sunny terrace overlooking the pool and a parking space in the underground garage.

S-01 1363

€140,000

Oroteanda Bajo



Stunning, fully furnished & equipped, 5 bed, 3 bath (master en suite) detached villa with heated pool on 2,000sqm plot. There is a garage for 4 cars and aircon and central heating throughout. This is a property has to be seen to appreciate all that it has to offer.

S-05 1380

€1,250,000

Tel: 922 703 725 / 627 230 360

Email: carolhale.tpp@gmail.com • Web: www.tenerifeproperty.com

Tenerife Prime Property

Golf del Sur, Las Adelfas II



Spacious, part-furnished 2 bed, 2 bath (master en suite) corner villa on sought after complex with pool. The property has a large lounge/dining area, separate kitchen, wraparound terrace and gardens and rooftop terrace which enjoys lovely sea, mountain and golf course views. Extras: full air conditioning throughout.



S-02 1342

€222,250



PROPERTIES IN ALL AREAS REQUIRED FOR LONG TERM RENTAL - CLIENTS WAITING!

Torviscas Bajo, Santa Maria



Fully refurbished and fully furnished 33sqm studio apartment on sought after touristic complex with pools and close to beach and amenities. The property has a lounge/diner/American kitchen and semi-separate double sleeping area and a large sunny roof terrace. Excellent income from holiday rentals.

S-00 1385

€168,000

Aldea Blanca, Res. Oasis



Lovely, part-furnished, 2 bed, 2 bath (1 en suite) bungalow-style property on quiet, secure residential complex with swimming pool and off-road parking. Lounge/dining area, American-style kitchen, conservatory and a large, sunny patio. A lovely family home close to all amenities.

S-02 1377

€159,000

Chayofa, Chayofa Country Club



Choose from a great selection of beautifully furnished and equipped studios, 1 or 2 bed apartments and 3 bed villas on this lovely resort with swimming pools, tennis courts, gym, community parking and Reception, just 5 minutes' drive from the sea front.

Prices from €99,950

Los Cristianos, Dinastia



Beautiful, fully furnished, ground floor 2 bed, 2 bath (1 en suite) apartment with an exceptionally large terrace. This apartment is very tastefully furnished and has a fully equipped kitchen. There are lifts throughout the complex and there is a community swimming pool and pool bar.

S-02 1348

€285,000

San Miguel, El Roque

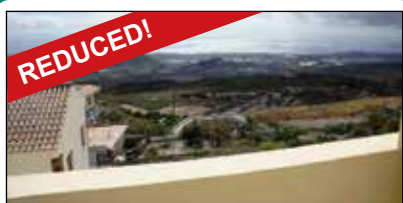

Spacious, fully furnished, 4 bed, 3 bath (1 en suite) house on a plot of 750m2 with large lounge, separate fully fitted kitchen, games room and two roof terraces. This is a lovely family home in a quiet Canarian village.

S-04 1335

€315,000

Valle San Lorenzo, Edf. JJ Efigenia



Spacious, fully furnished 3 bed, 2 bath (1 en suite) apartment with lounge, sep. kitchen, 2 balconies to the front, 2 enclosed terraces to the rear, and a parking space in the garage.

S-03 1324

€135,000

Amarilla Golf, Augusta Park



Lovely, beautifully furnished top floor 2 bed, 1 bath apartment on popular complex with pool. The property has a large lounge/diner, American style kitchen, alarge front terrace with lovely sea views and balconies off both bedrooms.

S-02 1378

£155,000 Sterling

Los Cristianos, El Mirador



Beautifully presented and furnished, 1 bed, 1 bath apartment (105sqm total) in sought after complex with pool, situated close to all amenities and the sea front. The property has a lounge/dining area, American-style kitchen and 2 large terraces with lovely sea views. Extras include aircon.

S-01 1389

€213,000

Tel: 922 703 725 / 627 230 360

Email: carolhale.tpp@gmail.com • Web: www.tenerifeproperty.com

Los Abrigos
www.studio4decor.net
Info@studio4decor.net
922 749 793 / 626 955 725

Studio 4 Decor

NOW OPEN
MONDAY – FRIDAY,
9.30AM – 1.30PM,
AND 3.00PM – 6.00PM

QUALITY FURNITURE TO SUIT ALL BUDGETS



STUDIO4DECOR offers a unique, one-on-one service aimed at taking the stress out of furnishing your property. From single items such as lamps, mirrors, curtains, pictures or ornaments to complement your new decor, we can help.

- ✓ Full re-upholstery service available
- ✓ Bespoke sofas, headboards and pelmets
- ✓ Beautiful made-to-measure curtains
- ✓ 1,000's of fabric swatches to choose from



Call into our Los Abrigos Showroom (29 Calle La Marina, Edificio Bogavante) and let us help turn your ideas into reality.

Beautiful interiors at a price you can afford!

UK Political Developments Continue to Drive Pound

Staying on top of the latest currency news can help you time your transfers more effectively, so find out what you should be looking out for over the next couple of weeks...

The Pound (GBP) struggled to gain last week after Q3 UK GDP showed the slowest rate of growth in nearly a decade, while ongoing political developments ahead of the 12th December general election continued dominating headlines. Over the last fortnight the GBP/EUR exchange rate fluctuated between €1.15 and €1.17 as UK political developments continued to drive demand ahead of the 12th December general election. The EUR/GBP exchange rate, meanwhile, edged up from £0.85 to £0.86 while GBP/USD drifted from \$1.29 to \$1.27. Political news remains

the driving force behind GBP exchange rate movement, with hopes that the upcoming general election could see the Conservatives secure a majority and break the current Brexit deadlock in parliament lending Sterling some support. However, GBP gains were capped last week as the UK's preliminary growth figure for the third quarter revealed the slowest rate of growth for almost a decade. Tej Parikh, Chief Economist at the Institute of Directors (IoD), said: "The UK economy has been in stop-start mode all year, with growth punctuated by the various Brexit deadlines."

Last Thursday also saw Germany's economy avoid a technical recession in the third quarter, with the flash GDP figure rising unexpectedly from -0.2% to 0.1%. Meanwhile, the US Dollar (USD) began to flag after optimism surrounding a "Phase One" US-China trade deal increased following Beijing's announcement that it would renew its US poultry imports. Larry Kudlow, the White House's Chief Economic Advisor, also commented that the mood between the two superpowers was "pretty good" and that they had made "very good progress" towards a deal.

The UK's political developments will continue to drive the Pound this week, with any signs that the Tories can consolidate their lead in the polls boosting Sterling as a sense of political stability

returns. This Wednesday will also see the House of Commons' inflation report hearings. These could weaken the Pound if the Bank of England (BoE) hints at any upcoming rate cuts due to disappointing inflation data.

Meanwhile, Euro (EUR) investors will be awaiting this Thursday's ECB Monetary Policy Meeting Accounts. Concerning

comments about the Eurozone's outlook could prove EUR-negative.

Looking ahead to this Friday, Germany's flash Markit Manufacturing PMI for November could further heighten concerns for the Eurozone's economy, with Germany's largest sector expected to remain mired in contraction territory.

At Currencies Direct we're here to talk

currency whenever you need us, so get in touch if you want to know more about the latest news or how it could impact your currency transfers. Since 1996, we've helped more than 250,000 customers with their currency transfers, just pop into your local Currencies Direct branch or give us a call to find out more.



+34 922 971 781

canaries@currenciesdirect.com
currenciesdirect.com



Mi casa es su casa

Want to save money on your overseas currency transfers? With offices across Spain, our expert teams are here to help you feel at home when it comes to moving money abroad.

Whether you're purchasing property or need to transfer your pension, simply pop into one of our local branches for a chat about your options.



Contact us for more information

La Zenia

Calle Salvador Dali, No 6
Playa Flamenca Orihuela Costa,
03189, Alicante
+34 965 994 830
costablanca@currenciesdirect.com

La Marina

Avenida de Londres 1ª, Local 6,
Urb La Marina San Fulgencio,
03177, Alicante
+34 965 994 830
costablanca@currenciesdirect.com

Mazarrón

Avenida los Covachos,
Camposol B, Mazarrón,
30875, Murcia
+34 968 976 383
costablanca@currenciesdirect.com

Quesada

Calle Azul, Local 7,
Ciudad Quesada,
Rojales, 03170, Alicante
+34 965 994 830
costablanca@currenciesdirect.com

..... **currenciesdirect.com**

TENERIFE'S FAVOURITE BRITISH BAKERS



IT'S OFFICIAL!
We're **THE BEST** bakery in Tenerife!



Ample free parking

Fresh coffee and snacks on our outside terraces in Los Cristianos and Las Chafiras

Daily Specials

FRESH, NOT FROZEN!

A huge assortment of breads, sausage rolls, quiches, cakes, freshly made sandwiches, hot toasties and wraps, all with a choice of fillings.

FIND US AT:

LOS CRISTIANOS:
Avenida Los Playeros
(Main street)
Tel: 922 798 133

LAS CHAFIRAS:
Fundadores
Co-operativa
No. 74

BOTH SHOPS OPEN DAILY FROM 7.00AM - 9.00PM (MONDAY - SATURDAY), AND 8.00AM - 3.30PM (SUNDAYS)

NOW AVAILABLE:

HOMEMADE
Toasted teacakes, potato cakes and savouries
ALL FRESHLY BAKED IN-STORE!



Baked under Licence - Hovis - THE ORIGINAL, multi-seed granary bread!

LAS CHAFIRAS BOOK SHOP

NOW ONLINE!
www.laschafirasbookshop.com

The Bookshop is located at Calle Luciano Bello Alfonso No 5 in Las Chafiras (behind and above Pit Team Sur and the Golf Shop, and opposite Marrero Homes). Books cost just €3.00 but we offer a 'Buy two get one FREE' system and we buy books we don't have for 50 cents each.

We now have more than 10,000 books to choose from, either in the Shop itself, or via the internet (www.laschafirasbookshop.com), where you can 'browse' our inventory and order - we will be happy to deliver to anyone not able to get in.

Should you come to the shop and no one is in, just call us on either 609 714 276 or 627 230 360 - we're never very far away and will get back as fast as we can - while you have a coffee at one of the many cafés nearby!



ACT

+34 922 736 728

APP for mobile and laptop
NOW AVAILABLE!

...looking after your Digital World!

T: 922 736 728

WATCH LIVE UK TV NOW **ACT**

W: act-tenerife.com • Mon/Fri: 09.30 - 17.30hrs

T: 610 800 689

(10am - 6pm, Mon - Fri)

info@canaryvoip.com
canaryvoip.com



Computer Services:
PC Sales Repairs & Maintenance

Home and Business:

Networking:
Network Installation & Maintenance

VoIP Services
Network Installations

The Prestige Group

Agustin Millares 20, Armeñime, Adeje 38678

Interior & Exterior Sun Blinds

Tenerife's leading specialist in the manufacture, repair and installation of all types of awnings, canopies, interior and exterior blinds - manual or electric.



Outdoor Furniture

We offer a large range of exclusive garden and terrace furniture in a wide variety of styles, designs, fabrics and colours. We also have parasols and cushions.



Roller Shutters, Grilles & Garage Doors

Specialists in the manufacture, repair and installation of industrial and domestic shutters, security grilles and garage doors – electric or manual.



The Prestige Group is a trading name of JAC Enterprises S.L.

Tel: 922-740888

www.theprestigegroup.es

info@theprestigegroup.es

Showroom open
Monday to Friday:
9.00am to 5.00pm
Situated opposite the BP
garage in Armeñime

MY THAI LOUNGE

Puerto Colon Marina, San Eugenio

* COCKTAILS * FRESH JUICES * THAI FOOD
* QUALITY WINES * SELECTION OF BEERS



Come and enjoy the authentic Thai cuisine of the lovely, recently-opened *My Thai Lounge*, overlooking the beautiful Puerto Colon Marina.

This modern and family-friendly Thai Restaurant was created because of the spectacular views available from its first-floor location and spacious terrace overlooking the harbour.



How would you like to enjoy a romantic dinner with a glass of wine while watching the sun go down over the marina – or a night of fun with your whole family – allowing the Thai cuisine to surprise and delight your senses!

Whatever you are looking for, you will find it the *My Thai Lounge* with its wonderful ambience and the fabulous views the cherry on top!

 MYTHAILOUNGE KATRIEN

 (+34) 670 883 604

LOCAL 223, C.C. PUERTO COLON
38670 - ADEJE - TENERIFE

Closed on
Wednesdays

PUT A
HERO
IN YOUR
LIFE
FROM JUST
€194*



CAR INSURANCE THAT KEEPS YOU
ON THE MOVE WHEN YOU NEED IT

902 123 965



linea directa

BEST PRICE. BETTER COVER.

*Based on third party. Offer valid for new customers only. Subject to conditions. Ends 31/12/19.

WHY STEALTHY VIRUSES ARE MAKING YOU ILL

by James Gallagher, Health and science correspondent, BBC News

A trick used by viruses to make us sick - "stealth spheres" - has been discovered by scientists.

A trick used by viruses to make us sick - "stealth spheres" - has been discovered by scientists. It had been thought viruses were all lone wolves, each on a solo campaign of infection. Instead they can form "packs" of up to 40 viruses and surround themselves with a fatty sphere that makes them invisible to our body's defences. The team at the US National Institutes of Health say their findings rewrite the

textbooks of infection. The researchers were analysing stool samples from patients with either rotavirus or norovirus.

- **Rotavirus is the biggest cause of diarrhoea in children in the world**
- **Norovirus is so infectious it spreads rampantly through schools, care homes and frequently cruise ships**

"It blew my mind," said researcher Dr Nihal Altan-Bonnet, the head of host-pathogen dynamics at the National Heart, Lung and Blood Institute. "I had this preconceived notion... I couldn't believe it when I saw it in the stool, I just couldn't believe they'd be able to exist."

The conventional view is that a virus infects a cell, which is converted into a factory for making more viruses, which burst out as individual viruses into the body. Instead some are released as groups in spheres known as vesicles.

Experiments, published in



the journal Cell Host and Microbe, showed the spheres gave the viruses huge advantages.

- **The spheres acted like an invisibility cloak that prevents the immune system spotting the viruses**
- **The spheres protected the viruses from harsh environments including stomach acid**
- **And they helped viruses reach their target in larger numbers and overwhelm cells in the intestines**

The researchers infected animals with a set number of viruses that were either released on their own or packaged into the stealth spheres. Dr Altan-Bonnet told the BBC: "The animals that got the vesicles got disease much faster and had more severe symptoms. "We think by being inside [the vesicles] the viruses

become invisible and take longer to clear. "In the viral world it's always about having an edge and in a vesicle you have a leg up in the early stages of the infection."

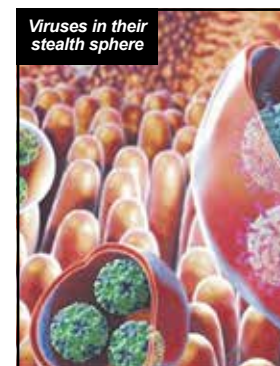

New therapies?

There are no drug treatments for either norovirus or rotavirus so the researchers hope targeting the vesicles will lead to new options. That could be a type of handwash that breaks down the spheres

or drugs that stop them forming in the first place.

Dr Altan-Bonnet says the need for better ways of tackling diseases like norovirus should not be underestimated: "Even healthy people like you or I, we get so sick we wouldn't go to work for days. "Its liquid coming violently out of both ends, there's a lot of economic cost, and for children and elderly it can be fatal."

The researchers say poliovirus and rhinovirus, a cause of the common cold, can also form these stealth spheres. Jonathan Ball, a professor of virology at the University of Nottingham, said the findings were a surprise. He told the BBC: "These vesicles seems to give the viruses increased infectivity when compared to naked individual viruses. "Why this increased concentration of viruses results in better levels of entry is unclear, and no doubt will be an important next question. "But what this data does indicate is how little we know about some of the most fundamental aspects of the virus lifecycle."

Organic solar cells set 'remarkable' energy record

by Matt McGrath, Environment correspondent, BBC

Chinese researchers have taken what they say is a major step forward for the development of a new generation of solar cells.

Chinese researchers have taken what they say is a major step forward for the development of a new generation of solar cells. Manufacturers have long used silicon to make solar panels because the material was the most efficient at converting sunlight into electricity.

But organic photovoltaics, made from carbon and plastic, promise a cheaper way of generating electricity.

This new study shows that organics can now be just as efficient as silicon.

What are organic solar cells?

The term organic relates to the fact that carbon-based materials are at the heart of these devices, rather than silicon. The square or rectangular solid solar panels that most of us are familiar with, require fixed installation points usually on roofs or in flat fields. Organic photovoltaics (OPV) can be made of compounds that are dissolved in ink so they can be printed on thin rolls of plastic, they can bend or curve around structures or even be incorporated into clothing.

What's stopped them becoming widely used?

In a word - efficiency. This is a measure of how much of the sunlight that shines on a panel can be turned into usable electricity. Commercial solar photovoltaics usually convert 15-22% of sunlight, with a world record for a silicon cell of 27.3% reached in this summer in the UK. Organics have long lingered at around half this rate, but this year has seen some major leaps forward. In April researchers were able to reach 15% in tests. Now this new study pushes that beyond 17% with the

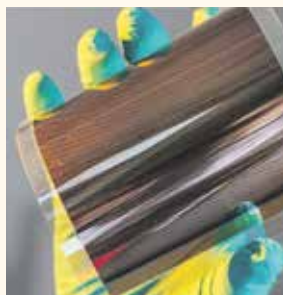

Organic solar cell module with six interconnected solar cells developed by Fraunhofer

cost of electricity in the US was 10.5 cents per kilowatt-hour, according to the US Energy Information Administration.

So what have these researchers done differently?

One of the things that has made OPV less efficient in the past is the fact that the organic materials have loosely bound molecules



An example of how a flexible, organic solar cell might look

authors saying that up to 25% is possible. This is important because according to estimates, with a 15% efficiency and a 20 year lifetime, organic solar cells could produce electricity at a cost of less than 7 cents per kilowatt-hour.

In 2017, the average

which can trap electrons and slow down the generation of electricity. So researchers have tried to get around this by putting different layers of material together in a what's termed a tandem cell approach. "Tandem cell means you have two devices built together in

the same structure," said one of the authors, Dr Yongsheng Chen, from Nankai University in Tianjin, China. "We have two layers of active materials, each layer can absorb different wavelengths of light. That means you can use sunlight in the wider wavelengths or more efficiently and this can generate more current."

How far are these from commercial production?

Not that far away according to the researchers. Dr Yongsheng Chen compares the OPV to organic light-emitting diodes, or OLED. This technology has been introduced in the past few years and is widely used for high-end TVs.

"These are already commercial, and they use a similar material to OPV," Dr Yongsheng Chen told BBC News. "The physical principle is the same, just a different direction, one is from solar to electricity, the other from electricity to light, the device and structure are similar." "I am very positive for OPV, and it may not need five years," he added.

What type of application might we expect?

Flexible, printed solar cells offer a wide range of possibilities. They can work indoors and they can be made semi-transparent, so they could be incorporated into windows and generate power during daylight. They offer huge potential for buildings as they are lightweight so might be ideal for deploying on the roofs of houses in developing countries where structures might not suit



Up close with a silicon-based solar panel

heavy silicon. They could be used on the roofs of cars, and in clothes, even in glasses to charge your phone while you are out and about.

"Their optional semi-transparency enables their use in windows or glass facade shading," said Dr Alexander Colsmann and expert on organic photovoltaics from the Karlsruhe Institute of Technology. "The very same properties render organic solar cells ideally

suited to also power mobile applications - camping gear, smart wearables or phone chargers, just to name a few - which have been only insufficiently addressed by classical solar cell technologies such as silicon."

What's been the reaction of others in the field?

Other experts in this field were generally positive. "This looks a remarkable result to me," said Dr Artem Bakulin, from Imperial College London. "The development of such new materials with previously unthinkable properties allowed them to achieve the reported record efficiency and, in general, makes OPV technology much more promising." Dr Feng Gao from Linköping University in Sweden also believes the new paper is significant. "This work is a very important contribution to organic solar cells and will certainly inspire new developments in the field," he said by email. "The tandem organic solar cells with record efficiencies in this work indicate great potential of organic solar cells for practical applications."

mueble4you

tenerife



Whole House Packages

Soft Furnishings

Interior Decoration

Including:

Rugs and Carpets, Lights, Vases, Artificial Flowers, Pictures, Mirrors Bedsreads and Throws

Home, Patio & Garden Furniture

New Stock Always arriving!

Including:

Rattan Garden Furniture
Dining Suites
Lounge Suites
Beds and Bedding



EVERYTHING IN OUR SHOWROOM IS AVAILABLE FOR IMMEDIATE DELIVERY!

www.mueble4you.com

**OPENING HOURS: Monday - Friday: 10.00am - 8.00pm
Saturdays: 10.00am - 2.00pm**

**Avda 7 Islas Canarias, No 2,
Poligono Industrial Llano del Camello,
LAS CHAFIRAS**

**Tel: 922 736 783 / 922 736 930
Email: antiquities.tfs@gmail.com
Email: sales@mueble4you.com**

facebook Mueble4you Tenerife



The manmade 'stars' changing the night sky

By Sarah Griffiths, BBC

The celestial patterns we see after dark have helped humans to set calendars and navigate for millennia, but could controversial new artworks change our view of the heavens?

Daubed on the rough walls of a cave in southwestern France are magnificent paintings of wild cattle, bison, horses and birds. They were left there by a prehistoric artist around 40,000 years ago. Above the shoulder of one bull are a series of seven dots that suggest these early human artworks hide a starry secret.

These dots, scientists suggest, represent a bright cluster of stars that form part of constellation Taurus, which hangs in the night sky above Europe during the winter. If correct, it suggests

dark, has helped us mark the passage of the months as it waxes and wanes. Telescopes have more recently provided us the opportunity to glimpse the more turbulent universe beyond our own solar system, where violent supernovae and supermassive black holes capable of swallowing entire galaxies lurk.

The arrival of the space age has also meant our view of the heavens can be artificially altered. Thousands of satellites and the odd space station can be spotted as if the sunlight reflects in the right way off their surfaces as they orbit, causing them to resemble stars moving steadily across the sky. The International Space Station (ISS), which circles the

as they pass over head, they are already posing a problem for astronomers looking out across the Universe. "Just as we have light pollution in cities, preventing us from seeing fainter stars, they [satellites] have a similar effect and even with larger telescopes it's still a difficult thing to combat," says Hannah Baynard, an astronomer at Royal Observatory Greenwich, in London.

While some may argue that the services provided by these satellites are worth a celestial makeover, there are plans to place new types of spacecraft into orbit that will have purely aesthetic purposes. Russian start-up StartRocket has revealed it wants to launch an array of up to 300 small satellites

"light pixel" probe into the stratosphere that has reflective film attached to it that works like a mirror, which StartRocket says could be seen from Earth. But sending a fleet of satellites into orbit to fly in formation will be far more technically challenging, while raising the money to pay for the array could also be a major stumbling block. StartRocket says it hopes to start its new service in 2021 by displaying a peace sign in the sky. The company has insisted its satellites will not fly over nature reserves or be visible outside major cities but the plan has met with strong opposition from those who peer into the heavens, both professionally and as a hobby. "Capitalism has reached stratospheric heights," says Ghina Halabi, an astrophysicist at the University of Cambridge, UK. "I'm 100% against this space pollution and commodification of the night sky."

But StartRocket is not alone. A Chinese company announced last year its ambitious plans to create a "fake moon," which according to reports in China could be launched by 2020. The reports gave no details about what it would look like or how it would work, but the chairman of the neatly named Chengdu Aerospace Science Institute Microelectronics System Research Institute Co Ltd, was reported to say it would reflect sunlight across an area of between six miles (10km) and 50 miles (80km).

He also told reporters that it would have a brightness "eight times" that of the real Moon. But since the initial announcement there has



SpaceX recently launched 60 of its Starlink satellites into orbit, which formed a "train" of artificial stars visible from Earth as they were deployed

these early human settlers in Europe understood far more about the positioning of the stars than we could have suspected. Thousands of years later, the ancient Romans picked out similar shapes from the pinpricks of light created by distant balls of fire. Later still the Vikings and European explorers used the same stars to help navigate their way to new lands.

Among the 6,000 stars potentially visible with the naked eye from Earth, there are a few easily identified markers of the night sky that have particular significance. Polaris, or the North Star, has been used by sailors for thousands of years to help them navigate because it appears to remain stationary to those in the Northern Hemisphere. The Moon, with the night time luminance providing a comforting presence in the

Earth 250 miles (400km) above us every 92 minutes, is the third-brightest object in the sky.

But for the first time in human history, the heavens are about to be deliberately altered in ways that will completely transform our view of the star-scape above us at night. Huge arrays of satellites and orbiting artworks, could create new manmade "stars" that will become night-time fixtures for future generations.

Our growing reliance upon

New "stars"

space technology is already causing the sky to become ever more crowded as hundreds of new satellites are launched each year. While most of us might only catch a fleeting flash of one

with retractable reflective sails into low earth orbit. Once there they can be arranged like pixels on a screen to depict company logos as star-like constellations as they catch the light from the sun. It would mean that for approximately six minutes a night, we could look up and gaze upon the first commercially branded



Caption: The Orbital Reflector, seen here on display at the Seattle Art Fair, was intended to be the world's first space sculpture

constellations.

So far, the firm has successfully launched a

been no update about the project. They are not the first projects to attempt to



install new star-like works of art in the sky. Another bid to launch a diamond-shaped reflective sculpture into orbit in 2018 failed. Nevada Museum of Art partnered with artist Trevor Paglan to launch Orbital Reflector. If successful it would have looked like a new star from Earth. The aim was to highlight the politics of

moment, a new one might spring to life."

For now, the Orbital Reflector has merely added to the growing mass of space junk – pieces of old spacecraft, decommissioned satellites and even frozen toilet waste – orbiting our planet.

"I think it's arrogant and conceited to think a human



The International Space Station can occasionally be seen streaking across the night sky when its solar arrays are angled to reflect sunlight in the right direction

space and question who has the right to use, commercialise and weaponise space.

But after launch the project was hit by a US government shutdown, preventing the team from getting permission to deploy the reflector and the team

can add art installations to 'beautify' something as sublime as the heavens," says Halabi. But William Fox, director of the Center for Art and Environment, Nevada Museum of Art, believes there is great value in using the heavens as canvas for human works of



Space agencies like Nasa and Esa track debris and junk that is orbiting the Earth in case it poses a hazard to operating spacecraft

lost contact with the artwork 35 days later. Paglan, however, hopes the orbiting sculpture may still bloom into being if short circuits as its electronics degrade accidentally trigger the inflation sequence. "I think of Orbital Reflector's current state as being in a state of unknown possibility, like an unopened present circling through the night sky," says Paglan. "And I, for one, will keep my eyes on the stars, knowing that at any

art. "Space art provides a larger frame in which to regard ourselves on the planet," he says. Indeed, prehistoric cave paintings hint that it is in our nature to try and understand our surroundings using artwork.

Of great concern, however, is the risk projects like this will pose to other spacecraft. The space around Earth is already looking increasingly crowded. China has plans

... cont. on page 44

ALUMINIUM & GLASS

We manufacture and install all kinds of aluminium and glass products.

ARTENGLASS

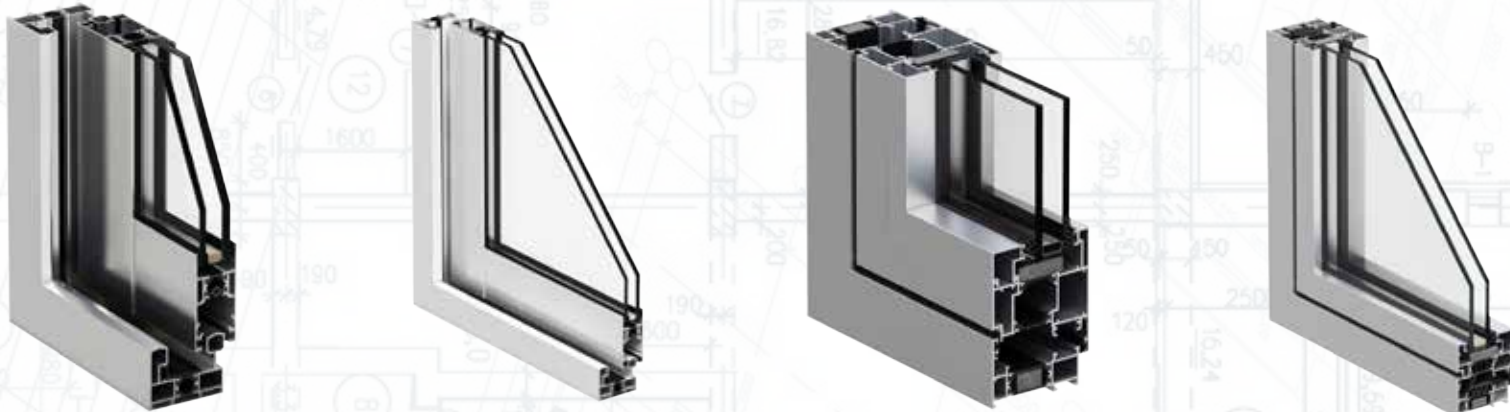

- ALUMINIUM DOORS AND WINDOWS
- GLASS CURTAINS
- KITCHEN GLASS SPLASHBACKS
- CONSERVATORIES
- POOL FENCE SURROUNDS
- AWNINGS AND INTERIOR BLINDS
- ROLLER SHURRERS, etc...

Ctra. General TF, 66 (Local Izquierda, Mom:83), Valle San Lorenzo, Arona

Tel: +34 627 906 456 / +34 922 764 187

info@artenglasstenerife.com

ALUMINIUM & GLASS



www.artenglasstenerife.com



... cont. from page 42

to build its own space station, which would also be visible periodically with the

– they all looked very bright because they started out in a very low orbit,” Baynard says. However, SpaceX says the satellites will grow

objects in the sky, there is a growing risk of accidents too. There is already around 8,400 tonnes of debris and junk currently racing around

satellites if they collide – in 2009, a defunct Russian satellite smashed into a functioning US commercial satellite, breaking both spacecraft into at least 2,000 pieces, dramatically increasing the amount of debris in orbit in the process.

Nasa currently tracks thousands of pieces of debris down to the size of a marble and regularly performs avoidance maneuvers to keep its satellites safe. The International Space Station has also had to make several maneuvers to avoid debris during its 20 years in orbit. (Read more about the quest to clean up space junk.) “These incidents will be more commonplace as the skies become a crowded debris field of surveillance,

communication and spy craft,” Halabi warns. While there are international regulations in place to limit the increase in space debris and some have proposed clean-up to capture junk in nets, there are some who think a solution could be to turn the junk itself into art.

Dutch artist and innovator Daan Roosegaarde is working with the European Space Agency (Esa) on a Space Waste Lab to come up with innovative ways of tackling the growing space junk problem, including turning space junk into artificial shooting stars that could light up the sky like fireworks. The plan involves guiding fragments of debris down into the Earth’s atmosphere where they would burn up at a chosen

time. “If space junk isn’t waste, but is a resource, that changes the discussion and adds value,” says Roosegaarde. He claims the project could be realised within three years. If successful, it will resurface questions that humankind has wrestled with since our ancestors left their mark inside those caves in France. Are the paintings of animals and artificial stars merely aesthetic adornments or a sign of something more profound? Are they a mark of our own ingenuity? Or are they simply graffiti, desecrating of the awe-inspiring surroundings we find ourselves in.

As ever, beauty will be in the eye of the beholder. ■



As more satellites are launched into orbit, the space around our planet will become increasingly crowded

naked eye if completed. SpaceX has also been granted permission to launch nearly 12,000 Starlink satellites to provide broadband internet access in remote locations. The first 60 of the Starlink satellites were launched in May at an altitude of 273 miles (440km), something that was immediately spotted by star-gazers. “When SpaceX’s Starlink went up – launched in a big long line

fainter as they move into higher orbits.

Eight other companies are also planning satellite internet service, including Amazon’s subsidiary Kuiper Systems, recently filed an application for permission to launch 3,236 broadband satellites. Both SpaceX and Amazon insist they are addressing concerns about the potential light pollution their satellites might cause.

But with all these extra

the Earth as speeds of up to 18,000mph (28,800km/h). This hail of debris can damage and even destroy

The International Space Station has also had to make several maneuvers to avoid debris during its 20 years in orbit



Burning space junk up in the atmosphere could create meteor showers on demand that would outshine even the most spectacular fireworks display

IMF: What is it and why does it matter?



The decisions made by the International Monetary Fund (IMF) affect people around the world. But what is the IMF, why is it important, and what criticism does it face?

What is the IMF?

The IMF is an international organisation with 189 member countries. They work together to try to stabilise the global economy. Any country can apply to join,



as long as it meets a few requirements. These include providing information about its economy and paying in a sum of money called a quota subscription. The richer the country, the higher its quota.

IMF in numbers

- **1944** year the IMF was founded
- **189** member countries
- **\$1tn** total amount it can lend its members
- **0%** interest rate on loans to low-income countries

The IMF does three main things to monitor and support the economy:

1. Tracks economic and financial events, monitoring how countries are performing and identifies potential

risks, like trade fights or Brexit uncertainty

2. Advises its members on how to improve their economies

3. Issues short-term loans and assistance to countries who are struggling (These loans are mainly funded by quota subscriptions. In 2018, Argentina received the largest loan in the IMF’s history at \$57bn (£44.5bn).)

The IMF can lend its members a total amount of \$1tn.

What is discussed at meetings?

Bankers, government officials and company bosses discuss the most important economic issues of the day at the IMF’s meetings. Members then try to make sure their plans are co-ordinated. It’s expected that trade tensions, weak economic growth, a slowdown in manufacturing and companies’ debts will be big topics this year.

What are its main achievements?

The IMF is often described as a “lender of last resort”. In times of crisis, countries look to it for financial assistance. Economists like Harvard University’s Benjamin Friedman have said it’s difficult to measure the organi-



Kristalina Georgieva (left) has replaced Christine Lagarde as IMF head

sation’s success because we can’t know if its policies are “worse than whatever the alternative would have been”. However, some praised the Fund’s role in supporting Mexico after it declared it would be unable to repay its debts in the early 1980s. More recently, Brazil obtained IMF loans

tire debt two years ahead of schedule.

What are the main criticisms?

The conditions the IMF imposes on countries it lends money to have sometimes been described as “harsh”. In the past, these have in-

cluded lower government borrowing, cutting corporate taxes and opening up their economies to foreign investment. Greece was where

the eurozone financial crisis started back in 2009, and the hardest-hit economy.

After it received bailout loans from the IMF, Greece had to make some changes. Critics said the austerity - intended to get government borrowing needs down - was excessive and did damage to the economy and



English economist John Maynard Keynes (centre) argued for a single world currency

in 2002 to avoid defaulting on its debts. The government was able to turn the economy around relatively quickly, and pay off its en-

cluded lower government borrowing, cutting corporate taxes and opening up their economies to foreign investment. Greece was where

society. The unemployment rate in Greece still remains

... cont. on page 46



EUROMUEBLE

www.euromueble.es

**MORE THAN 2.000 DIFFERENT!!
ITEMS FOR IMMEDIATE DELIVERY**



27 DIFFERENT!! MATTRESSES SIZE FOR IMMEDIATE DELIVERY

27cm

TRANSPORT FREE ASSEMBLY

90x190 135x190 150x190
189€ 280€ 310€



~~39€~~
29€
Chair

~~59€~~
189€
Mattress

TRANSPORT FREE ASSEMBLY



~~799€~~
559€

3 Seater Sofa with bed plus Chaislongue with Storage Box

~~139€~~
95€
Shoerack
70x153x18
XKIT



~~359€~~
249€
Bed Sofa

TRANSPORT FREE ASSEMBLY

~~399€~~
279€
Wardrobe
159x200x46
XKIT



~~239€~~
159€
Chest of Drawers
90x108,5x39,5
XKIT

PAY YOUR SHOPPING IN 24 MONTHS INTEREST FREE



~~299€~~
199€
Fridgefreezer
213L capacity



~~1429€~~
999€
Full Kitchen

INCLUDES 5 HOME APPLIANCES
FRIDGEFREEZER - RANGE HOODS - OVEN - COOK TOP - SINK



~~429€~~
299€
Table with 4 Armchairs
XKIT



~~339€~~
235€
Washing Machine
60x85x56

7 kg A+ 1000 RPM 15 PROGRAMS



EUROMUEBLE
IN FRONT OF BUS STOP

OPEN MONDAY TO SATURDAY FROM 09:00AM TO 20:00PM

follow us on



SAN MIGUEL DE ABONA
Poligono Industrial Las Chafiras
Rambla Modesto Hdez. González, 47
Tlf.: 922.736.084

WE SPEAK SPANISH, ENGLISH, FRENCH, GERMAN, ITALIAN AND PORTUGUESE

THE LARGEST CHAIN OF FURNITURE STORES IN THE CANARY ISLAND - 12 STORES

... cont. from page 44

high at 17%, down from a peak of over 27% in 2013.

Who heads it?

Kristalina Georgieva has recently taken on the top job at the IMF - managing director.

The economist was previously chief executive of the World Bank, and has succeeded Christine La-

garde.

Ms Georgieva is the first person from Bulgaria to lead the IMF, one of the poorest members of the European Union (EU). Since the organisation was created, a European has traditionally been in charge, with a US national taking on the presidency of the World Bank. Ahead of her first annual conference in her new role, Ms Georgieva warned that Brexit will be "painful" for the UK



and the EU, whatever form it takes.

Why was it created?

The IMF was created out of the Bretton Woods Conference in 1944 in the United States. It was attended by delegates from 44 countries during World War Two, including the United Kingdom, the United States and the Soviet Union. They discussed financial arrangements for the

expected end of the war, including how to set up a stable system of exchange rates and how to pay for rebuilding damaged European economies.

Two organisations were later set up to meet these aims: The International Monetary Fund, and the World Bank. Members of the newly-founded IMF agreed to a system of fixed exchange rates, which would stay in place until the early 1970s. ■

Fall of Berlin Wall: How 1989 reshaped the modern world

Brian Hanrahan, BBC

World events often move fast, but it is hard to match the pace and power of change in 1989.



It culminated in one of the most famous scenes in recent history - the fall of the Berlin Wall. The wall came down partly because of a bureaucratic accident but it fell amid a wave of revolutions that left the Soviet-led communist bloc teetering on the brink of collapse and helped define a new world order.

How did the Wall come down?

It was on 9 November 1989, five days after half a million people gathered in East Berlin in a mass

protest, that the Berlin Wall dividing communist East Germany from West Germany crumbled. East German leaders had tried to calm mounting protests by loosening the borders, making travel easier for East Germans. They had not intended to open the border up completely. The changes were meant to be fairly minor - but the way they were delivered had major consequences.

Notes about the new rules were handed to a spokesman, Günter Schabowski - who had no time to read them before



Brian Hanrahan reports on the rapid developments that led to the collapse of the Berlin Wall

his regular press conference. When he read the note aloud for the first time, reporters were stunned. "Private travel outside the country can now be applied for without prerequisites," he said. Surprised journalists clamoured for more details. Shuffling through his notes, Mr Schabowski said that as far as he was aware, it was effective immediately. In fact it had been planned to start the next day, with details on applying for a visa. But the news was all over television - and East Germans flocked to the border in huge numbers. Harald Jäger, a border guard in charge that evening, told Der Spiegel in 2009 that he had watched the press conference in confusion - and then watched the crowd arrive.

Mr Jäger frantically called his superiors, but they gave no orders either to open the gate - or to open fire to stop the crowd. With only a handful of guards facing hundreds of angry citizens, force would have been of little use. "People could have been injured or killed even without shots being fired, in scuffles, or if there had been panic among the thousands gathered at the border crossing," he told Der Spiegel. "That's why I gave my people the order: Open the barrier!" Thousands flowed through, celebrating and

crying, in scenes beamed around the world. Many climbed the wall at Berlin's Brandenburg gate, chipping away at the wall itself with hammers and pickaxes.

A turbulent year had reached a climax

Why did the Wall come down?

After World War Two, Europe was carved up by

UK, France and the USSR - with the eastern part occupied by the Soviets. East Germany, officially known as the German Democratic Republic, became the Soviet Union's foothold in Western Europe. But Berlin was split four ways, with British, French and American zones in the west of the city and a Soviet zone in the east. West Berlin became an island surrounded by communist East Germany. The wall was eventually built in 1961

communist bloc. Mikhail Gorbachev, the comparatively young Soviet leader who took power in 1985, introduced a reform policy of "glasnost" (openness) and "perestroika" (restructuring). But events moved far faster than he could have foreseen.

Revolutionary wave

Reform movements were already stirring in the communist bloc. Years of activism and strikes in Poland culminated in its rul-



There were emotional scenes as East Berliners entered the West

because East Berlin was haemorrhaging people to the West.

By the 1980s, the Soviet Union faced acute

ing communist party voting to legalise the banned Solidarity trade union. By February 1989, Solidarity was in talks with the



The BBC reports from the scene as the Berlin Wall goes up



Poland's Solidarity movement was successful in partially free elections

the Soviet Union and its former Western allies, and the Soviets gradually erected an "Iron Curtain" splitting the East from the West. Defeated Germany was divided up by the occupying powers - the US,

economic problems and major food shortages, and when a nuclear reactor at the Chernobyl power station in Ukraine exploded in April 1986, it was a symbolic moment in the impending collapse of the

government, and partially free elections in the summer saw it capture seats in parliament. Though the Communists retained a quota of seats, Solidarity

... cont. on page 48

500sqm
DISPLAY AREA!



Calle Tilena, 19, LAS CHAFIRAS



922 749 664

649 574 851

OPENING HOURS

Monday – Friday:
9.00am – 5.00pm

Saturday:
10.00am – 2.00pm

- ✓ Second Hand Store
- ✓ Household Clearances
- ✓ We Buy Your Furniture and Pay **CASH!**
- ✓ Delivery/Collection Island-wide



Email: losabrigosauctionroom@hotmail.com
Web: second-hand-tenerife.com

WE HAVE NEW STOCK ARRIVING EVERY DAY!



... cont. from page 46

swept the board wherever it was allowed to stand. Hungarians, too, launched mass demonstrations for

calling for independence. In the heat of August, Hungary opened its borders to Austria in the west, allowing East German refugees an escape. The Iron

But by then the revolution had spread to East Germany itself.

East Germany rebels

It began with demonstrators rallying for freedom in the centre of the city of Leipzig. On 9 October, within days of East Germany celebrating its 40th anniversary, 70,000 people took to the streets.

There were calls for free elections from West Germany, and talk of reform from East Germany's new communist leader Egon Krenz. No-one knew the fall of the Wall was weeks away. In late October parliament in Hungary, which had been among the first to hold mass demonstrations, adopted legislation providing for direct presidential elections and multi-party parliamentary elections. And then on 31 October, the numbers demanding democracy in East Germany swelled to half a million. Mr Krenz flew to Moscow for meetings - he recently told the BBC that he had been assured German reunification was not on the agenda.

On 4 November, a month after the East German protests had begun, around half a million people gathered in Alexanderplatz in the heart of East

Berlin. Three days later, the government resigned. But there was no intention to give way to democracy and Egon Krenz remained head of the Communist Party and the country's de facto leader. He would not be there long. Five days later, Mr Schabowski gave his world-changing press conference.

Why didn't the Soviets use force?

Earlier in '89, Beijing demonstrators in Tiananmen Square who had called for



Many East Germans were overcome by emotion as they crossed into Austria

a song, 'I (Did) It My Way.' So every country decides on its own which road to

over as the ousted leader fled his palace and angry crowds stormed it.

He and his wife Elena were captured and executed on Christmas Day. More than 1,000 people were killed in unrest before and after the revolution, setting Romania apart from the largely bloodless events elsewhere.

Postscript to 1989

And the Soviet Union itself? In 1990, Latvia, Lithuania and Estonia took advantage of their newfound political freedoms to vote out their communist governments and make moves towards independence. The Soviet Union was falling apart, but Mr Gorbachev made one last ill-fated attempt to reform it by calling together the leaders of the 15 Soviet republics. Hardline communists opposed to his reforms pre-empted him, attempting a coup while he was on holiday in Crimea in August 1991 and putting him under house arrest. The coup was defeated in three days as pro-democracy forces rallied round Boris Yeltsin, president of the Russian republic. But it was the death knell for the USSR, and one by one its constituent republics declared independence. By the end of the year the Soviet flag had flown for the last time. ■

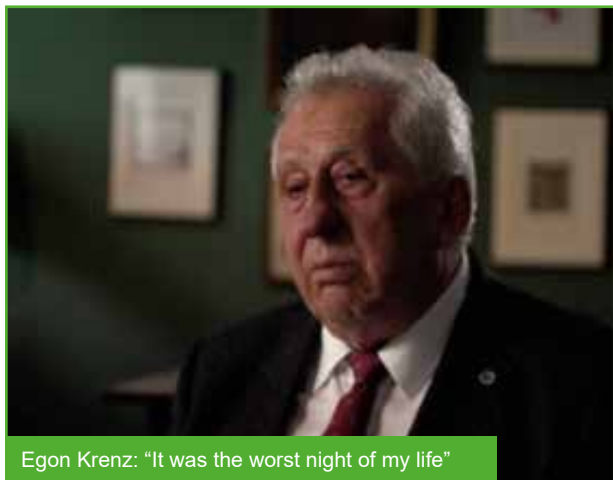

Egon Krenz: "It was the worst night of my life"

democracy in March. In May, 150 miles (240km) of barbed wire were dismantled along the border with Austria - the first chink in the Iron Curtain. Hungary's 1956 revolution was brutally suppressed by the Soviets, but this was succeeding. By August, the revolutionary wave had truly re-ignited on the fringes. Two million people across Estonia, Latvia and Lithuania - then part of the Soviet Union - held one of the most memorable demonstrations of the so-called Singing Revolution when they formed a 370-mile (600km) human chain across the Baltic republics

Curtain was buckling. Czechoslovakia, whose push for liberalising reform had been brutally suppressed in 1968, provided another means of escape. East Germans could travel to the neighbouring socialist nation without restriction, and began to flood the West German embassy there by the hundreds, eventually being evacuated to the West by train.

Czechs still shiver from Soviet 1968 invasion

East Germany ended up closing its border with Czechoslovakia in October to stem the tide.



The Romanian revolution was the only one in Eastern Europe that year that saw bloodshed

democracy in China were crushed in a major military crackdown. The USSR had used its military to put down rebellions before. So why not now? Within the Soviet Union itself, it did, killing 21 pro-independence protesters in the Soviet republic of Georgia. But elsewhere in the communist bloc, they did not. In a break with Soviet policy, Mikhail Gorbachev decided against using the threat of military might to quell mass demonstrations and political revolution in neighbouring countries. "We now have the Frank Sinatra doctrine," foreign ministry spokesman Gennady Gerasimov told US television. "He has

A new chapter in European history

On 3 December, Mr Gorbachev and US President George HW Bush sat side by side in Malta, and released a statement saying the Cold War between the two powers was coming to a close.

The 1989 wave of revolutions was not over yet. Student demonstrators in Prague clashed with police, triggering the Velvet Revolution which overthrew Czechoslovak communism within weeks. In Romania, demonstrations ended in violence and saw the fall of communist dictator Nicolae Ceausescu. A new government took



More than half a million people gathered in Prague for this November 1989 demonstration as Czechoslovak communism was overthrown

Could the world cope if GPS stopped working?

BY TIM HARFORD

What would happen if GPS - the Global Positioning System - stopped working? For a start, we would all have to

engage our brains and pay attention to the world around us when getting from A to B. Perhaps this would be no bad

thing: we'd be less likely to drive into rivers or over cliffs through misplaced trust in our navigation devices.

Pick your own favourite story about the kind of idiocy only GPS can enable. Mine is the Swedish couple

who misspelled the Italian island of Capri and turned up hundreds of miles away in Carpi, asking where the sea was.

But these are the exceptions.

Devices that use

... cont. on page 50





EL PATIO

GARDEN FURNITURE



WE ALSO SUPPLY FURNITURE FOR BARS & RESTAURANTS!



**SITUATED DIRECTLY BEHIND THE BINGO HALL
IN LAS CHAFIRAS**

C/ Argentina, 7, LAS CHAFIRAS INDUSTRIAL ESTATE (San Miguel de Abona)

+34 922 736 203

info@patiosur.com • www.patiosur.com

**Hot Spring Spas
Titanium Heat Pumps
Pool Covers and Rollers
Saunas**



**Designed by BMW Group
Design Works USA.**



Aqualux Pools and Spas
Calle Daniel Feo Feo, Nave 5, Las Chafiras, Tenerife
Tel: 922 736 944 / Mob: 619 781 924
www.aqualuxspas.eu
Email: aqualuxtenerife@gmail.com

... cont. from page 48

GPS usually stop us getting lost. If it failed, the roads would be clogged



with drivers slowing to peer at signs or stopping to consult maps. If your commute involves a train, there'd be no information boards to tell you when to expect the next arrival. Phone for a taxi, and you'd find a harassed operator trying to keep track of her fleet by calling the drivers. Open the Uber app, and - well, you get the picture. With no GPS, emergency services would start struggling: operators wouldn't be able to locate callers from their phone signal, or identify the near-

est ambulance or police car.

There would be snarl-ups at ports: container cranes need GPS to unload

- these are other industries mentioned by a UK government report that pegs the cost of GPS going down at about \$1bn

ships. Gaps could appear on supermarket shelves as "just-in-time" logistics systems judder to a halt. Factories could stand idle because their inputs

(£820m) a day for the first five days. If it lasted much longer, we might start worrying about the resilience of a whole load of other systems that might



Russia has denied Israeli suggestions that it is behind ongoing disruption of GPS signals at Israel's Ben Gurion airport

didn't arrive just in time either. Farming, construction, fishing, surveying

not have occurred to you if you think of GPS as a location service.

It is that, but it's also a time service.

GPS consists of 24 satellites that all carry clocks synchronised to an extreme degree of precision. When your smartphone uses GPS to locate you on a map, it's picking up signals from some of those satellites - and it's making calculations based on the time the signal was sent and where the satellite was. If the clocks on those satellites stray by a thousandth of a second, you'll mislay yourself by 200km or 300km.

So if you want incredibly accurate information about the time, GPS is the place to get it. Consider phone networks: your calls



GPS pioneers Richard Schwartz, Brad Parkinson, James Spilker Jr and Hugo Fruehauf were awarded the Queen Elizabeth Prize for Engineering

ing on the time.

If GPS were to fail, how well, and how widely, and for how long would backup systems keep these various shows on the road? The not very reassuring answer is that nobody really seems to know. No wonder GPS is sometimes called the "invisible utility". Trying to put a dollar value on it has become almost impossible. As the author Greg Milner puts it in Pinpoint: How GPS is Changing Our World, you may as well ask: "How much is oxygen worth to the human respiratory system?"

It's a remarkable story for an invention that first won support in the US military because it could help with bombing people - and even it was far from sure it needed

GPS pioneers awarded Queen Elizabeth Prize for Engineering

it. One typical response was: "I know where I am, why do I need a damn satellite to tell me where I am?"

The first GPS satellite launched in 1978

- but it wasn't until the first Gulf War, in 1990, that the sceptics came around. As Operation Desert Storm ran into a literal desert storm, with swirling sand reducing visibility to 5m (16ft), GPS let soldiers mark the location of mines, find their way back to water sources, and avoid getting in each other's way. It was so obviously lifesaving, and the military had so few receivers to go around, soldiers asked their families in America to spend their own money shipping over \$1,000 (£820) commercially available devices.

Given the military advantage GPS conferred, you may be wondering why the US armed forces were happy for everyone to use it. The truth is they weren't but they couldn't do much about it. They tried having the satellites send in effect two signals - an accurate one for their own use, and a degraded, fuzzier one for civilians - but companies found clever ways to tease more focus from the fuzzy signals. And the economic boost was becoming ever plainer. In 2000,



China's rival Beidou service is expanding rapidly, with more than 10 satellite launches in 2018

... cont. on page 52

Tenerife Property Shop are honoured with two Awards at The European Property Awards 2019

of Asia Pacific, Africa & Arabia, The Americas and the UK, and celebrate the very best projects and professionals in the industry. **Tenerife Property Shop** was chosen from over 200 companies spread across the European regions and have proved themselves to be the very best in the real estate sector.

Tenerife Property Shop represents two generations of a family business, maintaining the key found-

ations of honesty and integrity throughout more than three decades of success in Tenerife. The majority of the Tenerife Property Shop team have been working with the company for very many years, creating an excellent foundation of knowledge and strength, plus continuity of service to their clients.

With a focus on evolution to meet changing markets and international situations, **Tenerife Prop-**

erty Shop has built a solid and sustainable company around their exceptional quality of service and support for their clients, and fully deserve the awards that they have been honoured with.

All the staff of **Tenerife Property Shop** are very proud to receive these awards, which are testimony to all the hard work and dedication given in assisting clients.



Congratulations go out to **Tenerife Property Shop**, who this year are recipients of awards in not one, but two categories, having been presented with a **5 Star Award for Best Real Estate Agency Canary Islands**, and an Award Winner for **Best Real Estate Agency Website Spain**,

at the **European Property Awards 2019-2020**, the largest, most prestigious, and widely recognised event in the industry.

Presented at Royal Lancaster Hotel London on 24th October, the **International Property Awards and European Property Awards** are judged by an

independent panel of 96 industry experts, chaired by Lord Caithness and Lord Best, and focus on design, quality, service, innovation, originality, and commitment to sustainability. The European Awards are part of the International Property Awards that include the regions

For more information about
Tenerife Property Shop S.L.
visit www.tenerifepropertyshop.com
Tel: +34 922 714700 e: info@tenerifepropertyshop.com

For more information about
The European Property Awards
visit www.propertyawards.net
Contact PR and Marketing Manager, Dawn Wightman
T: +44 1245 250981 e: pr@ipropertymedia.com



RESIDENCIA HEALTH POLICY

- ELITE COVER e.g. Age: 20 - 45€ per mth
- ELITE COVER e.g. Age: 40 - 60€ per mth
- ELITE COVER e.g. Age: 60 - 93€ per mth

SMALL BUSINESS/COMPANY POLICY

- ELITE COVER e.g. Age: 20-49 - 48€ per mth
- ELITE COVER e.g. Age: 50-54 - 57€ per mth
- ELITE COVER e.g. Age: 55-60 - 68€ per mth

NB Sample prices. Terms & Conditions Apply



CAR INSURANCE

	Third Party	TPFT	Comp
Renault Clio 1.2	209€	210€	270€
Seat Ibiza 1.4	209€	215€	270€
Ford Fiesta 1.6	209€	220€	270€



€ - CASH BACK - €

The more policies you do, the more you save!



For existing Liberty Seguros customer - 60€ per policy

For new customers, 30€ for 1st policy then 60€ per policy

(Minimum premiums, Terms & Conditions apply - NEW, not cancelled or replaced policies)

Offer valid 26/09-23/12/2019 for all NEW qualifying policies



Great Prices & Guarantees
Policies in English, German or Spanish
and much more



HOME INSURANCE - in Safe Hands

CONTENTS		BUILDINGS	Contents & Buildings		
Cover	- COST	Size m ²	- COST	Covers	- COST
6,000€	- 83€	50	- 85€	12,500€ & 50 m ²	- 127€
12,500€	- 84€	75	- 92€	15,000 & 100 m ²	- 137€
15,000€	- 84€	100	- 103€	20,000 & 200 m ²	- 180€
20,000€	- 85€	125	- 115€	30,000 & 300 m ²	- 238€
25,000€	- 86€	200	- 141€		
30,000€	- 87€	300	- 182€		

NB Sample prices. Terms & Conditions Apply

661-908-980



Tenerife Insurance Services SL

922-735-672

Calle Clara Toledo Gomez Local A, Las Chafiras & Av el Palm Mar, Palm Mar

... cont. from page 50

President Bill Clinton bowed to the inevitable and made the high-grade signal available to all.

The American taxpayer puts up the billion-odd dollars a year it takes to keep GPS going, and that's very kind of them. But is it wise for the rest of the world to rely on their continued largesse? In fact, GPS isn't the only global navigational satellite system.

There's a Russian one, too, called Glonass - although it isn't as good. China and the European Union have their

own well-advanced projects, called BeiDou and Galileo respectively. Japan and India are work-

but they might also make tempting military targets in any future conflict, and you can imagine a

There are land-based alternatives to satellite navigation. The main one is called eLoran but

their national systems. One big appeal of eLoran is its signals are stronger. By the time GPS signals have made their 20,000km (12,000-mile) journey to Earth, they're extremely weak - which makes them easy to jam, or to spoof, if you know what you're doing.

People paid to think about these things worry less about the apocalyptic scenarios - waking up one day to find the whole thing offline - and more about the potential for terrorists or nation states to wreak havoc by feeding inaccurate signals

to GPS receivers in a certain area. Engineering professor Todd Humphreys has shown spoofing can down drones and divert super-yachts. He worries attackers could feasibly fry electricity grids, cripple mobile networks or crash stock markets.

The truth is it's hard to be sure how much damage spoofing GPS signals might do. But just ask those Swedish tourists in Carpi. Knowing that you're lost is one thing; being wrongly convinced you know where you are is another problem altogether. ■



GPS technology was extremely useful for allied soldiers during the Gulf War ground offensive against Kuwait

ing on systems too. These alternative satellites might help us ride out problems specific to GPS -

space war knocking everyone offline. A big enough solar storm could also do the job.

it doesn't cover the whole world, and some countries are putting more effort than others into

Is It Better For Your Gut To Eat A Big Breakfast Or A Big Dinner?

by Liz Moody



We've talked a lot about what to eat, but when you eat can be just as important. You know that circadian rhythm we talk about in reference to our sleep all the time? The same biological clock also affects our digestive functions. "Our body's natural circadian rhythms dictate metabolic and physiologic function, including our gut," explains Desiree Nielsen, R.D., and author of Eat More Plants. "Being out of sync can lead to poor outcomes, such as a breakdown in gut barrier function."

So when is the ideal time to take in the bulk of your food?

Experts tend toward consuming your larger meal at the beginning of the day. "Gastric emptying, which is how quickly food travels through the stom-

ach, as well as absorption of nutrients, is thought to slow down in the evening. This means that eating a large dinner might lead to suboptimal digestion and absorption of the meal," explains Nielsen. The position of our bodies when we sleep can also cause problems. "Lying supine causes gastric acids to reverse back up to the esophagus," explains Allison Aaron, R.D., and founder of Nutrition Curator. "Not only is this acid reflux extremely uncomfortable, but if chronic, it can also be detrimental to the GI tract. Sometimes, it may require the reliance on medications that you could otherwise avoid by shifting away from consuming a large meal just before bed."

Beyond that, a big breakfast could be the

key to hitting your happy weight. "According to an adage and traditional medical practices, "Eat breakfast like a king, lunch like a prince, and dinner like a pauper," says Robert Graham, M.D. and founder of Fresh Med NYC. Modern science backs up the saying. "A study published in the Journal of Nutrition revealed that consuming breakfast and eating the largest meal in the morning may be effective for maintaining your body's optimal weight. Feeding the gut in the morning has been shown to aid in digestion and metabolism by reducing absolute energy intake over the course of the day."

That said, there are caveats.

"Digestion is influenced by many factors, from your level of stress during meal-

times to how well you chew your food," says Nielsen. "So, if mornings are crazy for you, eating a big meal might lead to poor digestion." To remedy this, Nielsen suggests drinking a couple of large glasses of water when you first wake up, then having your coffee or tea as you prepare a big healthy breakfast that you can take with you to work. "That way, you can eat when you feel your gut get going again—or when you're calmer and more able to focus on eating," she says.

Will Cole, D.C. and author of The Inflammation Spectrum, has found different results with different patients. "Those with more sensitive or sluggish digestive issues could come into trouble eating too much right before bed as it can impact their digestion (and sleep) throughout the night," he says. "But for some people, eating in the evening can help improve sleep quality. It's the heart of functional medicine: bio-individuality."

Overall, it seems like a safe bet to lean into a larger breakfast and smaller dinner—but be sure to pay attention to how your body is responding since at the end of the day (and the beginning of it!), everyone is different. ■

The Tenerife Property Guide

Tel: +34 609 714 276

george.thetpg@gmail.com

www.thetenerifepropertyguide.com



ADVERTISE WITH US AND BUILD YOUR BUSINESS!



MARRERO HOME



KITCHENS

Why should you come to Marrero Home?

- 1** We are specialists in KITCHEN DESIGN AND MANUFACTURE!
- 2** We offer the BEST PRICES!
- 3** We deliver your new kitchen the fastest!
- 4** We have a huge range of kitchens IN STOCK!
- 5** Our team of professionals is here to help you design your new kitchen!

WARDROBES

FLOORING

SOFAS AND SOFABEDS

FURNITURE

922 703 117

Avda. Claudio Delgado Diaz, 103 - Las Chafiras - San Miguel de Abona - TENERIFE

maderasarrero@maderasarrero.com

www.maderasarrero.com



Magic Moments
 Your One Stop Party Shop
All Your Christmas Goodies
In Store Now!

Cards - Calendars - Diaries
Crackers - Gift Bags & Tags

Food and Gift Hampers
Made to Order
 On Facebook or Call
 922 790 682 or 617 153 827
 Local 3, Garajonay, San Eugenio
 Between Quiron Hospital
 and Garden City
Normal Opening Hours
10am - 6pm

Adeje Farmers Market

Calle Archajara
Adeje



Saturday/Sunday: 8.00am – 2.00pm
Wednesday: 3.00pm – 7.00pm

Your requests! Our Solutions! Without Surprises!

ADVERTISING AND MARKETING IN TENERIFE

Tenerife Surprise is THE website to get to know the island, whether you want to come for a holiday, or move here permanently, Tenerife Surprise researches, describes and promotes the best professionals on the island to provide solutions for ALL your requests!



Tenerife Surprise is a marketing and advertising company, working online, providing services for any type of businesses in Tenerife. We are ready to help you anytime!



Calle Londres, Local LF-19,
FANABE, 38679, Adeje, Tenerife



f Tenerife Surprise
Instagram tenerifesurprise



642 796 365/88

www.tenerifesurprise.com ✉ tenerifesurprise1@gmail.com



Welcome back to the 60s

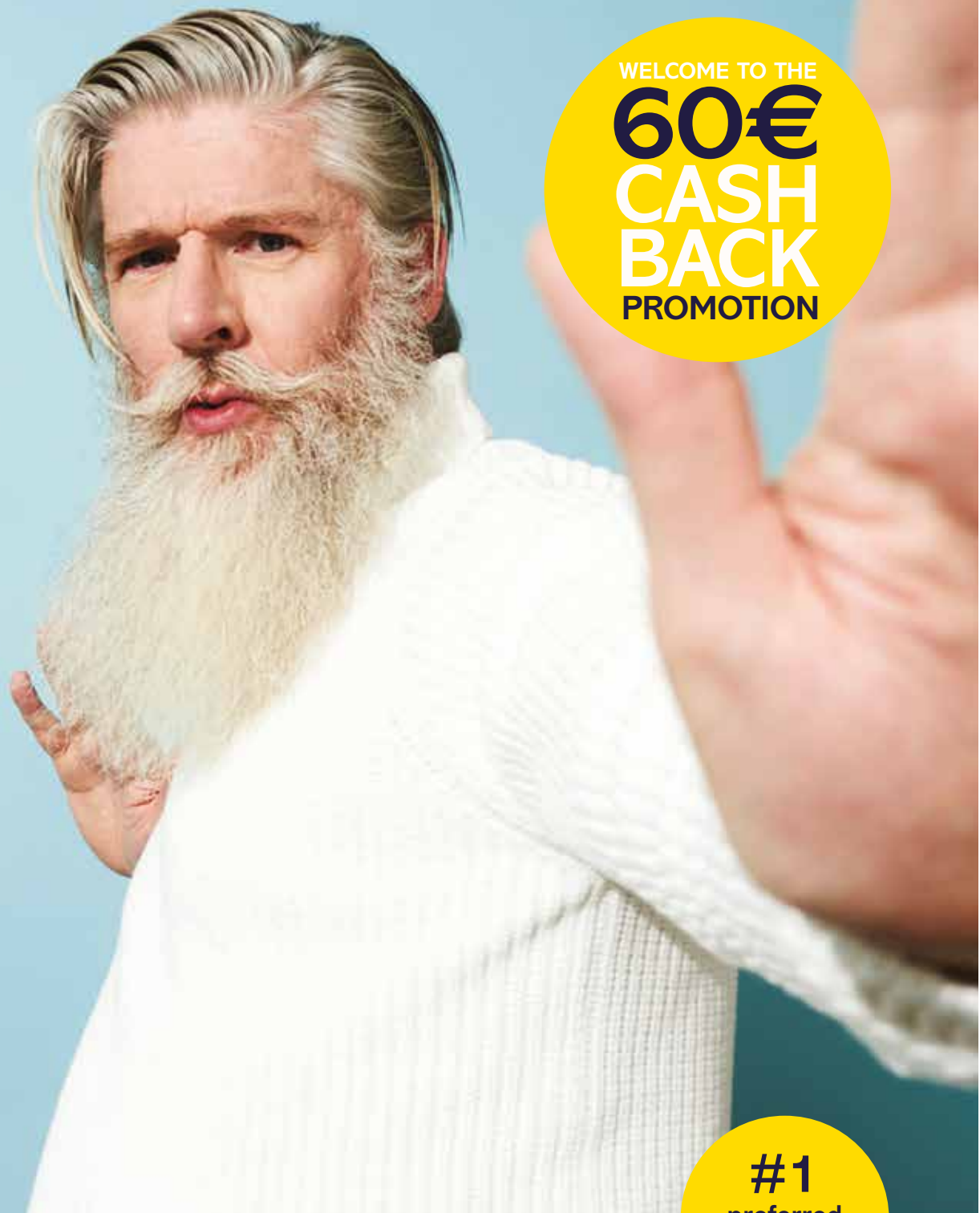

The more policies you take out, the more Cash you will get back!



Are you already a Liberty Seguros customer?

Take out a new policy: Car, Home, Life or Funeral and get 60€ Cashback for each policy! See how much you could get:



New client?

The first policy will give you 30€ Cashback and you will receive 60€ from the second policy onwards.



Liberty Seguros®

Visit your agent or call 91 342 25 49

Offer valid from 26th September 2019 to 23rd December 2019. Policies must be paid by direct debit. Applies to new car, home, life and funeral policies only. Not for renewals or replacements. Conditions and minimum premiums will be applied in all cases. Visit www.libertyexpatriates.es or ask your broker/agent for full details.

Sebastian & St. James

International Financial Advisers Limited

Speak to us about:

Investment Bonds
Regular Savings Plans
Pensions • Life Assurance
Overseas Pension Transfers (QROPS)
Pension Income Drawdown
International Health Cover

Sebastian & St James have specialist advisers in all aspects of financial advice for clients in Europe and the UK

Advice based on
integrity, trust & experience.

info@ss-ifa.com

+34 667 513 689 (Local Consultant)

+353 (1) 2343171 (International Head Office, Dublin)

+44 (0) 1446 704420 (UK Administration Centre)

www.ss-ifa.com

Registered with the FCA no. 582504

Sebastian & St James International Financial Advisers Limited is regulated by the Central Bank of Ireland

Money in the Bank or Money in a Bond? Make an informed choice!

The majority of us keep money in a bank account. Why? Because it is easy, relatively secure, and easily accessible. There is also a Deposit Protection Scheme in place which covers the amount in your bank account up to €100,000 or £75,000. So far, so good?

The Deposit Protection amount has been reduced from £85,000 which was the previous compensation limit. This means that if a bank or building society cannot meet its obligations and subsequently fails, or becomes insolvent, the maximum compensation you will receive will be £75,000 or £150,000 for a joint account (husband and wife).

What about growth on your savings?

Returns are not good, interest rates are hardly inflation-beating and your hard-earned cash is not really being put to work for you. In fact, the average savings account is paying less than 1% per year and some have even reduced to 0.2% or even 0.1%!

So how does this look in reality? Consider this: £20,000 in an average savings account with a gross interest rate of 1% will pay: £20,000 at 1% pa, equalling £200 each year before tax.

What is the alternative? - A Spanish Tax Compliant Bond

Setting up a Spanish tax compliant bond is no more difficult than setting up a bank account, and, once you have invested, you have easy access to your money: regular, or one-off withdrawals, to suit your needs.

which is subject to a strict legal and regulatory environment, to European Law, all applicable European directives and regulations and to meet European solvency margins. Under EU law, assets are to be used to repay policyholders should the company be wound up.

The returns over the last few years have been:

2012	2013	2014	2015	2016
8.0%	7.6%	7.5%	10.3%	5.8%

The growth on a Spanish Tax Compliant Bond is **free of tax** until a withdrawal is made -even then only the **growth** is subject to tax.

The growth on a Spanish Tax Compliant Bond is free of tax until a withdrawal is made -even then only the growth is subject to tax.

Any tax due is paid directly to the Hacienda and no Modelo 720 declaration is required for holders of this kind of Bond. The Bond can also be held jointly so there should be no liability to Succession Tax on the first death.

Any tax due is paid directly to the Hacienda and no Modelo 720 declaration is required for holders of this kind of Bond. The Bond can also be held jointly so there should be no liability to Succession Tax on the first death.

The Bond is backed by an AA-rated financial institution

The Bond is backed by an AA-rated financial institution which is subject to a strict legal and regulatory environment, to European Law, all applicable European directives and regulations and to meet European solvency margins. Under EU law, assets are to be used to repay policyholders should the company be wound up.

*Sebastian & St James International Financial Advisers Limited:
advice based on integrity, trust and experience.*

The Tenerife Property and Business Guide
 Editor and Publisher:
 Ali JS Gray NIE: X-5323899-C
 trading as Spanish Property Guides
 C/ Luciano Bello Alfonso No 5,
 LAS CHAFIRAS, San Miguel de Abona, 38639

General Enquiries:
 Tel: 922-703725
 E: george.thetpg@gmail.com
 W: thetenerifepropertyguide.com

Office Hours:
 Monday – Friday:
 9.00am – 5.00pm

The Tenerife Property and Business Guide takes all reasonable care to check the contents of every advertisement or article, but cannot accept responsibility for the claims or statements made in them. Also, statements or opinions expressed by contributors do not necessarily reflect those of the Editor or Publisher. Material featured in The Tenerife Property and Business Guide may not be reproduced without the express permission of the Editor. ©2018 The Tenerife Property and Business Guide.

Printed by: Artes Graficas del Atlantico, Gran Canaria
 Page 2 top-right image: Freepik.com

ENERGY PERFORMANCE CERTIFICATES IN SPAIN

DECEMBER 19 UPDATE

Some six and a half years have now passed since the legal requirement was brought in for Energy Performance Certificates to be carried out in Spain and it can be seen from the Canarian Government's official register that a total of 227,590 certificates have now been prepared and duly registered. This means that 2,380 certificates have been carried during the month of November, almost the same number as

in the same month last year. This of course groups both residential and commercial properties and those for sale as well as for rent in all of the Islands which together form the Canaries.

For those of you who are not aware of Energy Performance Certificates (EPCs), they were introduced in Spain and its dependencies by Royal Decree on 5th April 2013. This Law requires that, from

1st June 2013, an EPC must be obtained by the owner whenever a domestic or commercial property is Built, Sold or Rented.

Selling your property

From 1st June 2013 property owners are required by law to present an Energy Performance Certificate when a property is placed on the market and prior to any advertising. When the property is sold, the Notary

will need to see the EPC, termed the Certificado de Eficiencia Energética in Spain.

Renting your property

Either you or your agent, must obtain an EPC. An agent will not be legally allowed to offer or advertise your property for long term letting without one. Where

term rental again. If your property was built after 2007 you should already have an EPC provided by the seller. If you only rent your property out on a short term basis, for less than 4 months of each year, you may not need to have an EPC. If you are the tenant your landlord or the letting agent should be able to show you the EPC for your property.

and typical energy costs, and recommendations as to how you may be able to reduce energy use and save money.

An EPC allocates an Energy Efficiency Rating, ranging from 'A' (most efficient) to 'G' (least efficient). The Certificate, registered with the Canarian Government is valid for 10 years.

How to arrange an EPC:

If you are selling or renting out property, you will need to engage an Accredited Assessor, who will visit your property to inspect and then produce and register your properties Energy Performance Certificate.

If you have any questions, or wish to arrange for me, Philip Wright, to carry out your energy Performance Certificate please call me on 667 757 323.



a property has already been let prior to 1st June 2013, no EPC is required until one tenant leaves and the property is offered for long

The EPC contains:

Information about a property's energy use

December 19 DOG OF THE MONTH

Can YOU help this lovely little man?



The Refuges of Tenerife are so full of dogs at the moment they are struggling to cope. This young male dog is only a few months old and the Refuge is no place for him to grow up. He is a friendly and obedient dog – can YOU offer him a chance of a decent life?

The Centro de Proteccion Animal de Tierra Blanca is located off Junction 15 of the TF-1 by the restaurant Los Chasneros, just 200 metres above the TF-1. They don't ask for adoption fees, only a donation of food and some photos to let them know how your new pet is getting on in his/her new home. Please call Rachel on 629 031 273 for more information.



ELITE

Professional Cleaning and Maintenance Services

For Holiday Apartments, Villas, Private Homes and Offices

We can clean your holiday home & have it ready for you or your client

“LET US TAKE THE STRESS AWAY AND GIVE YOU PEACE OF MIND”

Tel: 922 789 795
 Mob: 696 922 597

Local 9,
 Club Atlantis Hotel,
 San Eugenio

elitetenerife@hotmail.com

Long Term Rentals

La Caleta, Oasis La Caleta

€POA
Newly furnished and fully equipped apartment in a very attractive resort in La Caleta. Nicely decorated, cozy bedroom with a comfortable bed 180 x 200 and sofa bed of a good quality in a living area. Beautiful garden, swimming pool with sun loungers and fantastic sea views. Underground garage. Within the walking distance of the beach El Duque and delicious... For full information see website or contact:

2nd Home Tenerife Ref: VKT1OASIS1
628 608 469

El Duque, Terrazas del Duque I

€POA
Spacious apartment for rent in El Duque area, just 10 min from the famous El Duque beach. The apartment offers a comfortable accommodation in two bedrooms with a double bed, two bathrooms (one with a bath, one with a shower), fully equipped separate kitchen, living area with the access to the large private terrace with a partial sea view. The resort has a... For full information see website or contact:

2nd Home Tenerife Ref: VKT2TDDE21
628 608 469

Playa Paraiso, El Cielo de Tenerife

€POA
Spacious one bedroom apartment located in a quiet complex in Playa Paraiso, 500 m from the beach. The apartment offers one bedroom with a double bed and access to the terrace, bathroom with a shower, kitchen connected with a living area (sofa

bed), TV, private terrace with furniture. There is a heated swimming pool in the resort. Local shops, bars and res... For full information see website or contact:

2nd Home Tenerife Ref: VKT1ELCIELO
628 608 469

La Caleta, Magnolia Golf Resort

€POA
This top floor duplex apartment offers amazing sea views and lots of sun in the tranquil yet attractive Magnolia Golf Resort in Costa Adeje. On the ground floor there is a kitchen with its own patio, a large living room with dining area and access to the sunny terrace. There is also a guest toilet with storage space on the ground floor and the access to th... For full information see website or contact:

2nd Home Tenerife Ref: VKT2MGR12F
628 608 469

Playa Paraiso, Adeje Paradise

€POA
Nicely decorated duplex for rent in a luxury resort in Playa Paraiso. One of the bedrooms (with two individual beds), bathroom with a bath, open kitchen and salon with an access to the sunny terrace with furniture are located on the groundfloor. The main bedroom with a double bed and another bathroom with a shower are situated upstairs. From here you can

FRINA Tenerife

business & property agent

+34 670 636 004 · +34 617 294 803

Calle Colón, 1st Floor, local 213, Puerto Colón, 38660 Adeje

tenerifebusinessforsale.com · tenerife-property.com

English, Spanish, Dutch, Flemish, German, French, Danish

visit us here

... For full information see website or contact:

2nd Home Tenerife Ref: VLT2ADP
628 608 469

Palm Mar, Penthouse

€POA
Beautiful 2 bedroom/ 2 bathroom apartment with front terrace and large roof terrace overlooking the village and coastline of Palm-Mar, very special property!

2nd Home Tenerife Ref: VKT2RP213AC
628 608 469

Palm Mar, Apartment

€POA
A beautiful house with two bedrooms, several sunny terraces, quiet in Palm-mar, in a beautiful complex with swimming pools. Unique opportunity!

2nd Home Tenerife Ref: VKT2RP214AC
628 608 469

Playa Paraiso, Paraiso I

€POA
Beautiful 2 bedroom apartment in Paraiso I, Playa Paraiso. With 1 bathroom, 1 laundry room, open plan

winter garden, terrace, sun roof terrace, private pool... For full information see website or contact:

2nd Home Tenerife Ref: VLTHAB28
628 608 469

Los Cristianos, Apartment

€1,700
Luxury apartment for rent in the centre of Los Cristianos, just 5 min walk from the beach. Completely renovated to high standard, the apartment consists of three bedrooms, two bathrooms (one with a shower, one with a bath), fully equipped kitchen (dishwasher, washing machine), living area with the access to the balcony. The guests can use a communal terrace... For full information see website or contact:

2nd Home Tenerife Ref: VLT3CRISTIANOS
628 608 469

La Caleta, Oasis La Caleta

€1,600
Spacious newly decorated townhouse, modern style, lounge, separate kitchen, laundry room, there is a large living area with a private terrace with barbecue on the groundfloor and two bedrooms with a bathroom upstairs. Balcony with swimming pool and partial sea views. Located within the walking distance from the shopping centre Gran Sur, 10 min by car from... For full information see website or contact:

2nd Home Tenerife Ref: VLT3OF16
628 608 469

Golf del Sur, San Blas Village

€1,550
Luxury house on residential complex, between Golf del Sur and Los Abrigos. It comes fully furnished and equipped to very high standards. Consists of 3 bedrooms with built-in wardrobes, a large living/dining room, a separate kitchen completely equipped with all the appliances (dishwasher incl), 2 large bathrooms and a separate toilet. It has a large corner... For full information see website or contact:

Tenerife Alizes Properties Ref: H3-1029
922 738653 / 626 274040

Golf del Sur, Las Adelfas II

€1,300
Lovely 2 bed-2 bath bungalow with linked self contained 1 bed apartment, on popular complex with pools, bar restaurant and close to the golf courses and main amenities. The main house has 2 double bedrooms, 2 bathrooms, separate fitted modern kitchen with utility room, large terrace overlooking the

communal pool, private parking for 2 cars, all equipped a... For full information see website or contact:

Tenerife Alizes Properties Ref: KV-0203
922 738653 / 626 274040

Playa Paraiso

€1,100
2 Bed, 2 Bath Duplex with terrace off lounge + roof terrace. Private parking. Available mid-January.
Tenerife Island Rentals Ref: 922 797438

El Duque, Apartment

€1,100
AVAILABLE UNTIL APRIL 2020. One bedroom apartment in central location in Costa Adeje close to the Costa Adeje Gran Hotel and Costa Adeje market. One bedroom, one bathroom, living room with American style kitchen and bathroom. The rental price includes water, electricity to be paid separately.

Tenerife Island Rentals Ref: APO378
922 797438

Del Duque area

€1,100
Winter let. 10 mins walk to the beach. Large 1 bedroom. Available till 30th April 2020.

Tenerife Island Rentals Ref: 922 797438

Playa Paraiso

€800
Large 2 bed, 2 bath with private parking. Modern apartment on complex with pool. Available now. Bills extra.
Tenerife Island Rentals Ref: 922 797438

922 797438

Torviscas Bajo

€800
Mareverde complex. 2 bed apartment. UK TV. Available till end of March 2020.

Tenerife Island Rentals Ref: 922 797438

Las Americas

€750
10 mins walk to beach. Available now. Recently renovated. Sea views. Bills extra.

Tenerife Island Rentals Ref: 922 797438

Golf del Sur, Terrazas de La Paz

€750
Modern, refurbished, ground floor, one bedroom apartment on a popular complex. Fabulous sea views. Water and electricity bills not included.

Homes & Away Ref: 1877
922 737 044

Amarilla Golf, Pebble Beach

€750
One bed bungalow in ideal location with superb views. Price includes water and electricity bills.

Homes & Away Ref: 1438
922 737 044

Golf del Sur, Parque Albatros

€675
Spacious, south facing, well-furnished one bed apartment with large terrace on popular complex. Close to all amenities.

Homes & Away Ref: 1785
922 737 044

San Eugenio Alto

€650

1 Bedroom apartment with small garden & terrace with sea view. Available now.

Tenerife Island Rentals Ref: 922 797438

Costa del Silencio, La Hacienda

€650
Top floor, fully furnished 1 bedroom, 1 bathroom apartment with lounge and American style fitted kitchen which leads off to a large terrace and its own stairs up to a private roof terrace. There is also a private parking space available and community swimming pools. Nice quiet residential complex.

Tenerife Prime Property Ref: 01 1168
627-230360

Los Abrigos, Apartment

€600
First floor 3 bedrooms apartment in a popular local village with stunning sea views. Water and electricity bills on top.

Homes & Away Ref: 1712
922 737 044

Los Abrigos, Apartment

€500
In central position, in the village of Los Abrigos, close to major amenities and a few minutes' walk to the sea, this one bed apartment is furnished and consists of 1 double bedroom, bathroom, living with American kitchen, and a small balcony. Includes garage space. Pets not allowed. Bills extra. Available from December, only long terms.

Tenerife Alizes Properties Ref: KV0212
922 738653 / 626 274040

Interested in advertising with The TPG?

Call us on 922 703 725



VACANT PROPERTY CHECKS / KEYHOLDING

Due to an increase in people asking for **Vacant Property Checks** over the last six months, and our help in averting major property problems recently, we would like to offer this Service at a **Discounted Rate**.

Whether you are away for a week, or for several months, this Service - offering the best value and our personal attention - may be of interest to you.

What does having this Service mean for you? It means that, simply, wherever you are, you will have peace of mind!

Professional Weekly Property Checks:

For more information, please call our office today:
Tel: 922 797 438 / 673 778 700
Email: info@tenerifeislandrentals.com



Tenerife Island Rentals & Buy Tenerife



Call Donna in our Los Cristianos office
+34-922 971 781 or Carol on +34-687 906 607

The Tenerife Property & Business Guide

Tel: +34 609 714 276

george.thetpg@gmail.com
www.thetenerifepropertyguide.com



ADVERTISE WITH US AND BUILD YOUR BUSINESS!

URGENTLY WANTED

Villas & Apartments to Rent

Tel: 0044-1663-763344

skyline
Travel Ltd

www.skylinetravel.co.uk

Avda Londres 1, Sur y Sol, Local 1
Los Cristianos, Arona 38650

Office: 922 797 438 / 922 751 587
Mobile: (00 34) 673 778 700

www.tenerifeislandrentals.com
info@tenerifeislandrentals.com



Tenerife Island Rentals & Buy Tenerife

Property Management

- ✓ Specialists in Long Term Rentals in south Tenerife
- ✓ With more than 17 years' experience, we are ideally placed to look after your property!
- ✓ We take care of every aspect and our experienced office and maintenance team are here to give you complete peace of mind.

Rent with Confidence

- ✓ Tenant satisfaction brings regular rental income
- ✓ Property checks and transparent maintenance work
- ✓ Central Admin Office in Los Cristianos
- ✓ Hands-on team offering a genuine, professional service



RENT WITH US!

**Come and talk to the experts - Call 922 797 438
or Email: info@tenerifeislandrentals.com**

**URGENTLY REQUIRED - ALL TYPES OF PROPERTY!
PROFESSIONAL CLIENTS WAITING!**

Business Section

OVER €350,000

Los Cristianos, Commercial Property

€1,300,000

Very central location, empty locals for sale 1903 m2 in total. **The Property Gallery Ref: com456**

922 719925 / 922 719889

Las Americas, Restaurant

€995,000

Switch to mobile/tablet view HERE This large freehold restaurant in Las Americas is more than well-established and located on a busy street. The locals are very cozy and charming with wooden roofs and stone walls. And measures 250 m2 plus a terrace of 50 m2 on the first floor overlooking a busy street. Moreover, is a large storage room, 2 guest toilets... For full information see website or contact:

FRINA Tenerife SL Ref: 2180
922 085191 / 670 636004

Los Gigantes, Hotel

€890,000

Location - Exclusive development - Quiet location - Central - Touristic area - Close to amenities - Close to restaurants / bars / cafes - Close to shops / Views - La gomera - Sea Additional - Viewing possibilities Rooms - American style kitchen - Bathroom - Hall / entrance - Lounge and dining area Quality - Furnished - Good con... For full information see website or contact:

Island Estates Ref: 407-HT6
922 790767 / 670 605414

Costa Adeje, Commercial Property

€650,000

We are pleased to offer this fantastic opportunity investment! A local operating as a restaurant in the heart of Las Americas nearby the beach and number of facilities situated on the main tourist passage. Distributed over 400m2 with terraces and fully equipped and furnished kitchen. The business has an up to date licence and high ranked performance across... For full information see website or contact:

Vym Canarias Ref: VS5181DN
922 787210 / 635 881888

San Eugenio Alto, Freehold Property

€630,000

Large freehold for sale, located in a complex in San Eugenio Alto. The local used to be a supermarket but is empty today and would need refurbishment before it can reopen as another business or supermarket. Details: The premises are spacious 585m2 plus terrace of 50m2 and a basement of 50m2.

FRINA Tenerife SL Ref: 2293
922 085191 / 670 636004

Las Americas, Empty Local

€530,000

200m2 Local being sold freehold. Originally used as a Chinese restaurant but is now empty. There is a 80m2 basement with fridges and a top floor which could be used as offices. Also included in the price are 3 garages spaces and storerooms. GREATLY REDUCED FOR A QUICK SALE.

Tenerife Prime Property Ref:

B-110

627-230360

Los Cristianos, Restaurant

€367,500

The restaurant is situated in a pretty courtyard just off the main beach in Los Cristianos. The business started as a carvery restaurant (which still exists), but in recent times the menu has been extended considerably, and the local next door was purchased to extend the size of the seating area to a total of 220 m2. This restaurant is very busy and opens... For full information see website or contact:

The Property Gallery Ref: COM478
922 719925 / 922 719889

Costa Adeje, Commercial Property

€360,000

Local area 347.92 m2 129 901 m2 storage

The Property Gallery Ref: Com508

922 719925 / 922 719889

Tenerife South, Jet-Ski Hire

€350,000

For sale with FRINA Tenerife is this long-established Tenerife jet ski excursion in the south. You will not find a jet ski business with a better reputation, newer jet skis, and less work than this. Moreover, this business comes with a unique opportunity/license allowing you to expand with another water sports business, which we can explain at a meeting. ... For full information see website or contact:

FRINA Tenerife SL Ref: 2080
922 085191 / 670 636004

€349,999 - €250,000

Palm Mar, Restaurant

San Miguel, Commercial Property

€329,175

air conditioning, modern

Vym Canarias Ref: VS5424D

922 787210 / 635 881888

Playa San Juan, Investment Property

€320,000

Apartment block located in the town center of Playa San Juan. A unique opportunity to buy an investment project, consisting of a ground floor shop unit and two very large apartments, all of which can be converted into more units for rental purposes. The property on the first floor has 4 bedrooms, a spacious lounge, separate kitchen & 2 bathrooms. The prope... For full information see website or contact:

The Property Gallery Ref: D1678
922 719925 / 922 719889

Palm Mar, Restaurant

€290,000

Full trading restaurant FOR SALE or for LEASEHOLD. Sold fully equipped and furnished. Been established for 8 years. On LEASEHOLD the price is 74.000 with a monthly rent of 1.100.

The Property Gallery Ref: COM537
922 719925 / 922 719889

Costa Adeje, Commercial Property

€280,000

The tourist underwater center has been operating in Tenerife since 1999. The center has excellent logistics to meet newcomers, experienced divers

and snorkelers. Very good location in the port 100 m from the ocean. Two high-speed boats are only 3 minutes walk from the center, which is very convenient for customers. They do not need to carry heavy equipment... For full information see website or contact:

Vym Canarias Ref: VS4667D
922 787210 / 635 881888

Puerto de Santiago, Car Leasing/Rental Business

€267,000

New on the market is this Car Rental for sale in Puerto Santiago, which is sold as a leasehold or a freehold. Furthermore, the business sells Tenerife excursions and the office has an ATM, which both provide to the healthy income. Premises of the Business for Sale You find the main office centrally in Puerto Santiago and a fully equipped workshop clos... For full information see website or contact:

FRINA Tenerife SL Ref: 2233
922 085191 / 670 636004

Costa Adeje, Commercial Property

€263,000

We are instructed to offer this well known restaurant for sale in the center of Adeje. It is currently functioning and is for sale with all the furniture, installations and goods. A very good business opportunity! Request your appointment and more information.

Vym Canarias Ref: VS4962D
922 787210 / 635 881888

San Eugenio Bajo, Restaurant

€259,000

After 16 years this is a well-established, year-round business from many regular and new guests due to its great location. Being sold as Freehold or Leasehold (traspaso is 59,000). The premises are well-maintained, interior: 80m2 plus terrace of 40m2. The dining area is bright and has tables for 34 dining guests, plus 34 for guests outside. There is a bar... For full information see website or contact:

FRINA Tenerife SL Ref: 2210
922 085191 / 670 636004

FRINA Tenerife

business & property agent

+34 670 636 004 · +34 617 294 803

Calle Colón, 1st Floor, local 213, Puerto Colón, 38660 Adeje

tenerifebusinessforsale.com · tenerife-property.com

English, Spanish, Dutch, Flemish, German, French, Danish

Playa Paraiso, Retail Business

€250,000

If you are looking for a well-established and easy-to-run business, you cannot miss this store for sale in a busy complex of Playa Paraiso. This store sells everyday products like snacks, drinks and sun lotion but also toys and quality suitcases and bags of brands like Valentino and Guess. The business shows a healthy income and especially the profit o... For full information see website or contact:

FRINA Tenerife SL Ref: 2237
922 085191 / 670 636004

€249,999 - €150,000

Arona, Commercial Property

€231,000

The business is sold complete, with all the equipment practically new: 8 motorcycles brand SEADOO 130 van of 9 seats for transport of customers 16 vests platform for pontoon zodiac support boat (with 2 spare balls) professional photography equipment costumes neoprene trunks for clients, etc...

Vym Canarias Ref: VS4585D
922 787210 / 635 881888

Costa Adeje, Commercial Property

€229,000

New locales in Adeje! High quality, excellent location! One local with a total area of 213m2 and a price of 229,000 EURO. Another local with a total area of 254m2 and a price of 265,000 EURO. Construction will be completed in September 2018. Prices from 229 000 euro call us for more information!

Vym Canarias Ref: VS4913D
922 787210 / 635 881888

Playa San Juan, Bar/Cafe

€225,000

This Traspaso Cafeteria for sale is located in Playa San Juan where it opened a year ago. It is known for an international menu offering brunch, burgers, Spanish specialties and a large variety of homemade bread and pastry. Moreover, it is popular due to its lovely location on the seaford. The owner owns several well-established businesses in Tenerife... For full information see website or contact:

FRINA Tenerife SL Ref: 2298
922 085191 / 670 636004

Puerto Colon, Excursion Business

€220,000

FRINA Tenerife is happy to offer this large fishing boat for sale in the busiest harbour of Tenerife South. This is the largest licensed fishing boat on the island and offers a unique fishing experience on the Atlantic Ocean whether you are an amateur or experienced fisher. The boat is licensed to go out with 12 passengers a trip which can be

FRINA Tenerife

business & property agent

+34 670 636 004 · +34 617 294 803

Calle Colón, 1st Floor, local 213, Puerto Colón, 38660 Adeje

tenerifebusinessforsale.com · tenerife-property.com

English, Spanish, Dutch, Flemish, German, French, Danish

from 4 to 7 ... For full information see website or contact:

FRINA Tenerife SL Ref: 2235
922 085191 / 670 636004

Costa Adeje, Commercial Property

€215,000

We are pleased to offer this great opportunity to own not only local but also a prospective business! Local of 135m2 distributed over two floors and with a private terrace in front. There is a possibility to buy only the local or local together with the equipment and all licences. Contact us for more details!

Vym Canarias Ref: VS5780D

922 787210 / 635 881888

San Eugenio Alto, Local

€205,200

BANK REPOSSESSION: Commercial local in San Eugenio Alto - near the Agua Park. 91.12 m2.

The Property Gallery Ref: n_234352
922 719925 / 922 719889

Los Cristianos, Other Business

€204,800

BANK REPOSSESSION: C/ Valle Menendez: It consists of 3 commercial properties, 380.17 m2. Local with 4 doors for access, 2 bathrooms, well situated in a central location with all kinds of services nearby. It is sold together with references n_262697 and n_260439.

The Property Gallery Ref: n_260439
922 719925 / 922 719889

Arafo, Investment Property

€198,500

C. Transversal Malpais, Arafo, (North) Old Canarian house with 410m2, one bedroom, private parking, garden.

The Property Gallery Ref: 73202564
922 719925 / 922 719889

Las Galletas, Excursion Business

€190,000

FRINA Tenerife offers this well-established water excursion for sale that is known for all-inclusive whales & dolphins experiences. Besides for whale watching the trips include open bar, refreshments, swimming, snorkeling, and a great atmosphere. The boat is fully licensed for tourist and whale excursions and have the yellow (blue) flag too. Furthermore... For full information see website or contact:

FRINA Tenerife SL Ref: 2246
922 085191 / 670 636004

Icod de Los Vinos, Commercial Property

€190,000

Shop Premises for sale with an internal area of 150m2, empty shop unit in the spanish village of Icod, built in two levels, great location just off the main street. It has toilets and an interior patio. Very good condition. Easy access.

The Property Gallery Ref: COM552
922 719925 / 922 719889

Los Abrigos, Commercial Property

€163,900

This local is also available for rent at 600 Euros / Month.

The Property Gallery Ref: 73053263
922 719925 / 922 719889

Costa Adeje, Commercial Property

€160,000

We have been instructed to offer for sale this very successful cabaret bar in Callao Salvaje, considered by many as the destination bar for all that is Callao. If you are not afraid of hard work, like a challenge, have excellent customer service skills, creative thinking and enjoy seeing all your efforts rewarded then this already very profitable cabare... For full information see website or contact:

Vym Canarias Ref: VS5357D

922 787210 / 635 881888

Las Americas, Commercial Property

€159,000

Warehouse: Large with cellar, three offices, two toilets, one new large freezer room, 12m2 cold storage, linear shelves, furniture, fully equipped to start the activity. Local rent 1.700 per month (been established for 10 years)

The Property Gallery Ref: Com536
922 719925 / 922 719889

Los Cristianos, Commercial Property

€157,500

Ten locals made into a large party/game bar with separate bar & terrace area. karaoke room, Large game room(for laser games) Ideal for birthday & other parties.

The Property Gallery Ref: COM529
922 719925 / 922 719889

Tenerife South, Other Business

€152,000

NEW ON MARKET! Established for more than 20 years in the south of Tenerife. If you dream of entering the property market here, this is the safe way to a strong position. Apart from the name, this fully equipped business includes a portfolio of more than 800 properties, including Bank Repossessions, thousands of clients, and a valuable list of agents, law... For full information see website or contact:

FRINA Tenerife SL Ref: 2112
922 085191 / 670 636004

Las Americas, Local

€150,000

Centro Commercial, Terranova. Playa de las Americas. 48 m2 Local with 90 m2 Terrace all ready set up for a BAR, fully equipped and ready to open. Option of a FREEHOLD also for 240.000 a LEASEHOLD IS 16.000a 5 YEARS RENEWABLE. 1.200 a PER MONTH RENT.

The Property Gallery Ref: COM483
922 719925 / 922 719889

€149,999 - €100,000

Adeje Town, Bar/Cafe

€140,000

This leasehold cafe in Adeje serves a large variety of international homemade dishes and pastry, which makes it popular for breakfast, lunch, dinner and take away. It is located centrally in Adeje town and the clients are both residents and tourists. The cafe was refurbished last year, so all machines are in great condition and the furniture modern and... For full information see website or contact:

FRINA Tenerife SL Ref: 2299
922 085191 / 670 636004

Las Americas, Bar/Cafe

€139,000

If you are looking for a Las Americas bar you cannot miss this successful business, which is famous for its amazing atmosphere, showing sports events and popular live entertainment several times a week. This bar has been open for more than 40 years and the current owner has only made this already well-established bar an even bigger success! Moreover, t... For full information see

The Tenerife Property & Business Guide

Tel: +34 609 714 276
 george.thetpg@gmail.com
 www.thetenerifepropertyguide.com



website or contact:

FRINA Tenerife SL Ref: 2197
 922 085191 / 670 636004

San Miguel, Excursion Business

€130,000

PRESS HERE for mobile/tablet view If you love the sea and dream of relocation to Tenerife, you cannot miss this long-established fishing excursion for sale. The boat is located in the South of Tenerife in the San Miguel harbor, where it has a fixed mooring. Today the excursion offered are quality fishing trips and whether you wish to do trolling, jigging... For full information see website or contact:

FRINA Tenerife SL Ref: 2138
 922 085191 / 670 636004

Puerto Colon, Excursion Business

€129,500

These 3 charter boats for sale rent out to tourists for private charters. Each of the boats can be rented from 1 to 6 hours, depending on the clients wish. Moreover, the boats can be rented with or without a private captain. This is a fairly easy business to run since many clients prefer going out on their own. The Charter Boats for Sale There are 3 d... For full information see website or contact:

FRINA Tenerife SL Ref: 2220
 922 085191 / 670 636004

Costa Adeje, Bakery

€129,000

New on the market is this Cafe & Bakery in Adeje for sale with FRINA Tenerife. The traspaso offers both the fully equipped bakery and a good cafeteria. The business opened 7 years ago and is more than well-established. And thanks to a great reputation, the buyer is sure to have clients from day 1! Premises in the

Bakery in Adeje The premises are 170 m... For full information see website or contact:

FRINA Tenerife SL Ref: 2227
 922 085191 / 670 636004

Costa del Silencio, Empty Local

€125,000

Beautiful 1 bedroom apartment with 2 terraces of 7.20 sqm facing West. The apartment is in excellent condition, fully furnished and located in a very nice apartohotel with heated pool, only 5 minutes walk from bars, shops and restaurants. There's a bus stop nearby.

Tenerifehome.com Ref: 1448-1218
 922 783066

Los Cristianos, Restaurant

€125,000

SWITCH TO MOBILE TABLET FRIENDLY VIEW FRINA Tenerife is happy to offer this successful gourmet restaurant for sale, which is known for a popular degustation menu combining local Canarian products with fine dining. Today the restaurant is open 6 days a week. It is open 2,5 hours in the afternoon for lunches and again from 19:00 to 23:30 in the evenings.... For full information see website or contact:

FRINA Tenerife SL Ref: 2184
 922 085191 / 670 636004

Puerto Colon, Restaurant

€125,000

New on the market is this Puerto Colon traspaso restaurant for sale with FRINA Tenerife. It is located on the ground floor of Puerto Colon commercial centre which secures plenty of footfall and harbour view. Moreover, the rent is more than fair for this size local and in this location! The premises are spacious 120 m2 plus a terrace of 30 m2 and you fi... For full information see website or contact:

FRINA Tenerife SL Ref: 2279

922 085191 / 670 636004

Golf del Sur, Restaurant

€120,000

FRINA Tenerife is happy to present this well-established restaurant in Golf del Sur. After 9 years in the same hands, the owners have built a good reputation and enjoys many returning guests both residents and tourists. It is known for Spanish tapas and British type food. Premises of the Restaurant in Golf del Sur This restaurant is very spacious insi... For full information see website or contact:

FRINA Tenerife SL Ref: 2221
 922 085191 / 670 636004

Torviscas Alto, Other Business

€120,000

In Torviscas Bajo area on a street

FRINA Tenerife

business & property agent

+34 670 636 004 · +34 617 294 803

Calle Colón, 1ª Floor, local 213, Puerto Colón, 38660 Adeje

tenerifebusinessforsale.com · tenerife-property.com

English, Spanish, Dutch, Flemish, German, French, Danish

visit us here

near the beach we have for sale a comprehensive supermarket of 270m2. It is located in the apartment complex known as Sunset Bay. It has electrical installation and refrigerators (with sanitary authorisation). The supermarket also has two cashiers. These commercial premises could also be used for other types of services.

The Property Gallery Ref: COM480
 922 719925 / 922 719889

Callao Salvaje, Cafe/Cake Shop

€110,000

This well-established French bakery for sale has been open for almost 7 years and is known for homemade and mouth-watering pastries. The high quality of the product and the fact that it is all homemade secures the owner a high profit and a healthy business. Premises of the Bakery for Sale The premises are spacious 240 m2 and is sold with all the bakin... For full information see website or contact:

FRINA Tenerife SL Ref: 2188
 922 085191 / 670 636004

Costa del Silencio, Empty Local

€109,000

1 bedroom apartment which has been completely renovated situated in an apartohotel. South - East facing terrace with view on the gardens. The complex offers a communal swimming pool and parking for residents only (access with remote control).

Tenerifehome.com Ref: 1311-0917

922 783066

Costa Adeje, Commercial Property

€109,000

Opportunity to acquire a successful gourmet restaurant that's been trading for over 7 years with the same owner. The property occupies a ground floor of 320m2. Excellent views from the terrace, over the sea, garden and communal swimming pool. Very well decorated. Large dining area, pub, large kitchen, terrace and toilets. Kitchen is fully equipped with tw... For full information see website or contact:

The Property Gallery Ref: COM534
 922 719925 / 922 719889

Tenerife South, Excursion Business

€105,000

This diving center for sale in Tenerife has been open for 4 years and has excellent reviews on TripAdvisor and Facebook. Tenerife has plenty of interesting diving spots and due to the warm climate, this is a steady business year-round. If you are an educated diving instructor who wishes to make your hobby your new life, you cannot miss this unique busi... For full information see website or contact:

FRINA Tenerife SL Ref: 2213
 922 085191 / 670 636004

Granadilla, Commercial Property

€100,900

Located in a area well connected via T-64 and by bus service. Near to amenities. Total built: 271,89 m2 Store room: 135.68 m2

business is located in San Eugenio Bajo and the pub measures 60 m2. It is a classic pub and super cozy wi... For full information see website or contact:

FRINA Tenerife SL Ref: 2267
 922 085191 / 670 636004

Costa del Silencio, Bar/Cafe

€89,000

SWITCH TO TABLET/MOBILE VIEW HERE This freehold bar is run by the same owner for 15 years and is more than well-established. It is especially popular among British guests and is known for a lovely Sunday Roast and Saturday Night. The premises consist of 2 combined locals and a covered terrace, which are included in the freehold. The inside has tabl... For full information see website

for pastry + other small machinery. Will al... For full information see website or contact:

Tenerife Prime Property Ref: B-154
 627-230360

San Eugenio Bajo, Fish and Chip Shop

€69,000

SWITCH TO TABLET/MOBILE VIEW This fish & chips Shop opened 25 years ago and is known for using local British products to make perfect fish & chips. It is a well-visited business, which also offers other fast foods and delivery. The premises are 25 m2 with a counter and an open kitchen. In front of the shop is a covered terrace of 12 m2 with tables for g... For full information see website or contact:

Piano Lessons

Learn at your own pace with a relaxed, friendly teacher to guide and support you.

Custom made lessons to suit all levels and musical interests.

I am experienced in preparing students for ABRSM Piano Exams.

Call Louise 686 014 355
 www.pianointenerife.eu

KEYBOARDS FOR HIRE

or contact:

FRINA Tenerife SL Ref: 2162
 922 085191 / 670 636004

Guia de Isora, Commercial Property

€85,000

Several commercial premises with the access from the main street and sea views. Good investment for rentals. 45m2, 52m2 y 55m2 of internal space. Rental prices from 600 to 900 euros aper month. Sale price from 85.000 eur up to 130.000 eur for each premise.

Vym Canarias Ref: VS5641D
 922 787210 / 635 881888

Las Americas, Bar/Cafe

€79,000

V i s i t TENERIFEBUSINESSFORSALE.COM for better pictures This is a rare opportunity to buy a first line café in Las Americas, which faces the busy promenade. With this, you do not only get a great location but also a business which has been established for 8 years and today's customers are a mix of all the tourists and different nationalities who visit and ... For full information see website or contact:

FRINA Tenerife SL Ref: 2183
 922 085191 / 670 636004

Las Galletas, Bar/Cafe

€79,000

Highly popular, profitable, and fully legal, sea-front bar/cafe in the attractive and vibrant seaside fishing village of Las Galletas. This ready-to-walk-in-and-take-over business can accommodate up to 40 persons in its spacious interior and outside terrace. The cafe operates excellent working hours (9.00am 5.00pm daily, 6 days per week) and has a highly ... For full information see website or contact:

Tenerife Prime Property Ref: B-111
 627-230360

Los Cristianos, Bar/Cafe/Restaurant

€72,000

Cake shop open since 1986 being sold with all machinery and a Peugeot Van included in the price. 25% of sales made in the shop & 75% to customers delivered on a daily basis. Rent of 950.00 per month. Machinery includes: Rotating oven, fridge, 2 x freezers, laminator, 3 x display fridges, tables for working, mixer

FRINA Tenerife SL Ref: 2159
 922 085191 / 670 636004

Los Abrigos, Bar/Cafe

€68,000

This traspaso for sale in Los Abrigos is a very popular bar-cafe in an excellent location. The business has been established for years and has many regular clients. And it has been open for 6 years and is a well-established business in a good area, which keeps expanding. Premises of the Traspaso for Sale The bar-cafe is spacious 130 m2 with a good siz... For full information see website or contact:

FRINA Tenerife SL Ref: 2266
 922 085191 / 670 636004

Los Cristianos, Other Business

€68,000

70m2 Local with terrace of 40m2. Could be used as a language school, office, gym or dentist. The price has been considerably reduced for a quick sale.

Tenerife Prime Property Ref: Local 02
 627-230360

Puerto Colon, Local

€60,000

Local / office in Terranova, Puerto Colon. Sold unfurnished. The building has a lift.

The Property Gallery Ref: COM509
 922 719925 / 922 719889

UNDER €50,000

Las Americas, Bar/Cafe

€49,000

Fully furnished Rent: 890 Euros per month
The Property Gallery Ref: Com550
 922 719925 / 922 719889

El Duque, Local

€45,000

◆ Location: Close to amenities, Close to the beach, Close to the coast, Touristic Area ◆ Close to: Beach, Restaurants / Bars / Cafes ◆ Rooms: Independent Kitchen ◆ Quality: Furnished ◆ Outside: Large Terrace ◆ Additional: Investment opportunity ◆
Property Alliance SL Ref: 0C3154
 922 777747

Las Americas, Bar/Cafe

€40,000

If you are looking for a bar in Las Americas that is perfect for a couple or a single person, you

Tenerife Prime Property

Tel: 922 703 725 / 627 230 360

Email: carolhale.tpp@gmail.com

Web: www.tenerifeproperty.com

Lovely 2 bed, 2 bath house and successful sea front bar/cafe for sale. Discount available if bought together, but for sale separately!

ALDEA BLANCA, RES. SAN MIGUEL OASIS



Lovely, part-furnished, 2 bed, 2 bath (1 en suite) bungalow-style property on quiet residential complex with access via electrically-controlled security gates, swimming pool and off-road parking. The bungalow has a lounge/dining area, American-style fitted kitchen, conservatory and a large, sunny patio. This is a lovely family home close to amenities and just 10 minutes' drive to the beach, golf courses and the airport.

Ref: S-02 1377

Price: €159,000

LAS GALLETAS SEA FRONT PROMENADE, BAR/CAFÉ



Highly popular, profitable and fully legal sea-front bar/cafe in the attractive and vibrant fishing village of Las Galletas This ready-to-walk-in-and-take-over business can accommodate up to 40 persons in its spacious inside space and outside terrace. The cafe operates excellent working hours (approx.. 9.00am - 5.00pm daily, 6 days per week) and has a highly loyal customer base. The owners, who have built the business from scratch have decided to retire. Accounts available.

Ref: B-111

Price: €79,000

must visit this cozy place, which is known for special beers, large cocktails, and a great atmosphere. The current owner had the bar for 5 years and built a good reputation. Premises of

Property

It has a good size for any kind of activities, such as pizzeria, fish or meat restaurant or any oriental specialties including 20 square

€40,000



Call Donna in our Los Cristianos office +34-922 971 781 or Carol on +34-687 906 607

the Bar In Las Americas This bar is cozy, warm and inviting. It measu... For full information see website or contact:

FRINA Tenerife SL Ref: 2215 922 085191 / 670 636004

Los Abrigos, Commercial

meters terrace. Facilities include a well equipped kitchen, inside seating for around 35 people, ladies and gents toilets with separate wash room, 7 flat screen televisions, 4 decoder boxes, pool table and dart boards. ... For full information

see website or contact:

The Property Gallery Ref: COM544 922 719925 / 922 719889

Las Americas, Mobility Vehicle Hire

€37,500

FRINA Tenerife offers this bike & scooter rental for sale, which has been established for 3 years and is located in a super busy area of Las Americas. This shop offers rentals of bikes, e-bikes, mobility scooters and, wheelchairs. The clients are both pedestrians passing by and clients who find the offers online. Included in the business for Sale The ... For full information see website or contact:

FRINA Tenerife SL Ref: 2185 922 085191 / 670 636004

Puerto de Santiago, Local

€30,000

♦ Location: Touristic Area, Close to amenities ♦ Close to: Coast, Restaurants / Bars / Cafes, Beach ♦ Views: Sea ♦ Quality:

Piano Lessons

Learn at your own pace with a relaxed, friendly teacher to guide and support you.

Custom made lessons to suit all levels and musical interests.

I am experienced in preparing students for ABRSM Piano Exams.

Call Louise 686 014 355

www.pianointenerife.eu

KEYBOARDS FOR HIRE

Furnished ♦ Outside: Sunny Terrace, Large Terrace ♦ Additional: Investment opportunity ♦

Property Alliance SL Ref: 0C2992 922 777747

Las Americas, Commercial Property

€20,000

Great position on this fantastic Tattoo Shop in central Playa de Las Americas. The shop has been tastefully refurbished and

has a nice reception area, the tattooing room, bathroom and storeroom. Very well equipped. Central area with lots of walk ins. Contact us now for more information! TRASPASO

Tenerife Belfin Properties Ref: B401-BP 692 146808

Las Americas, Other Business

€17,200

BANK REPOSSESSION: Calle Mexico: Commercial local on the ground floor of the commercial

centre; with access from the gallery. Located in a touristic area close to the centre of Playa de las Americas. M2: 46.93 Number of floor levels: 1 M2 at the back: 12.15 Number of access points: 1 Year of construction: 1975

The Property Gallery Ref: 118647

922 719925 / 922 719889

Las Americas, Empty Local

€2,500

If you are looking to build your own bar-restaurant in a prominent location, you will be hard pushed to find a better offer than this local to lease. The owner will give the new tenant a 5-year rental contract and offer a month rent-free to refurb the premises. Premises of the Local to Lease The premises are spacious 180 m2 and used to be a bar, bu... For full information see website or contact:

FRINA Tenerife SL Ref: 2205 922 085191 / 670 636004

Open every day

Abierto TODOS los DIAS



MODA Shopping



RESTAURACIÓN Food & Drink



SUPERMERCADO Supermarket



CINE y OCIO Cinema & Entertainment

PARKING GRATUITO FREE PARKING



tripadvisor

www.ccgransur.com



SALIDA EXIT 76 ADEJE TF-1

FRINA Tenerife S.L.

tenerifebusinessforsale.com

Merry Christmas
and Happy New Year

Jetski Business

New



Jetski Business, which is located in Gold del Sur. Golf del Sur is a great location for a jetski business since you have plenty of tourists year-round however, you have less competition and much lower rent. Included are 6 jetskis.

Ref.: 2307 Price: 139,000€

Profitable British Bar



This profitable British Bar is located in Las Americas and has been established for more than 25 years, so it has many regular guests and shows a more than healthy income. You cannot miss this, if you are looking for a successful business.

Ref.: 2306 From: 175,000€

Pool Bar-Restaurant



This large pool bar and restaurant is located in a busy complex in Los Cristianos. The inside premises of the restaurant are spacious 120 m2 with a fully equipped kitchen. Moreover, is a spacious terrace.

Ref.: 1909 Price: 105,000€

Well-established Bakery



This bakery is known for homemade pastry which are sold and delivered to cafes and bars in South Tenerife. The current owners had the bakery for 4 years and build themselves a solid business with a healthy income.

Ref.: 2301 Price: 65,000€

Adeje Bar-Cafe

New



This café has a great size for a couple or some friends that wishes to work together in a smaller business, it is 100 m2 inside with a terrace of 40 m2. Today the customer profile and local Spanish and especially German tourists.

Ref.: 2308 Price: 36,000€

Established Franchise in Fanabe



This café is a part of a popular and well-known sandwich franchise making it a successful and easy to run business. And this particular café has been established here since 2015 and very good reviews on Tripadvisor

Ref.: 2280 Price: 68,500€

Las Americas Restaurant



This large restaurant in Las Americas is located at the busy sea promenade enjoying plenty of footfall and wonderful views. It opened 7 years ago so, it is a very well-established and shows a healthy income.

Ref.: 2287 Price: 220,000€

Well-established Cafe-Bakery



Whether you are looking for an investment or a well-established business to run yourself, you cannot miss this popular café-bakery in San Eugenio Bajo and known for delicious homemade food, bread and pastry.

Ref.: 2296 Price: 275,500€

Bar-Cafe In Los Gigantes



This bar-café is known for gourmet burgers and British specialties. The business is not operating at the moment, hence the low traspaso price. It has tables for about 44 guests, is sold fully equipped and with the Bc-license.

Ref.: 2289 Price: 30,000€

Sea View Restaurant

Reduced



This fast-food restaurant is known for Belgium specialties and a lovely beach and sea view from the large terrace. The restaurant is 80 m2 with an open kitchen that offers a lot of newer equipment and machines.

Ref.: 2284 Price: 49,000€

Bargain Leasehold Cafe

Reduced



This cafe-bar is located in Adeje town and known to serve breakfast, lunch, and snacks in the evenings. It is in excellent condition, fully furnished and with a newer well-equipped kitchen. It is 55 m2 with a terrace of 25 m2.

Ref.: 2271 Price: 30,000€

Large Fishing Boat



This large Bertram 46 ft fishing boat is located in Puerto Colon Harbour and offers a unique fishing experience for both amateurs and experienced fishermen. The boat is licensed to go out with 12 passengers and had a refurb 2018.

Ref.: 2235 Price: 220,000€

Unique Excursion Boat

Reduced



This unique excursion boat for sale is a solar-panel driven boat, that sails up to 14 km/h. The boat is 21 feet with a u-shaped couch, back bench, and sundeck. The license allows the boat up to 10 passengers, including the captain.

Ref.: 2251 Price: 45,000€

Los Cristianos Beauty Salon



This salon has been established for several years and comes with many regular clients both tourists and residents. It is spacious 100m2 and fully refurbished for all kind of hair and beauty treatments.

Ref.: 2285 Price: 49,000€

Car Dealer With Workshop



This minimarket sells liquor, tobacco, souvenirs, beach products, and refreshments. The premises are 50 m2 with a terrace of 25 m2 – all fully equipped with shelves, racks, counter, etc. Also, the store has a toilet and a storage room.

Ref.: 2278 Price: 345,000€

Jet Bike & Parascending



This is a unique opportunity to get both a jet bike and a parascending business that is established for 10 years and in a prime location of Tenerife South, where it enjoys little competition and plenty of footfall.

Ref.: 2277 Price: 250,000€

San Eugenio Minimarket



This minimarket sells liquor, tobacco, souvenirs, beach products, and refreshments. The premises are 50 m2 with a terrace of 25 m2 – all fully equipped with shelves, racks, counter, etc. Also, the store has a toilet and a storage room.

Ref.: 2268 Price: 39,500€

Ice Cream & Crepe Bar



This business sells ice cream, cakes, and crepes. It is located in Golf del Sur and has no direct competitors in the area. It is an easy business to run and great for a single person or a couple who wishes for a light job in Tenerife.

Ref.: 2230 Price: 35,000€

Fanabe Freehold For Sale



This large freehold has a great location in Fanabe, it is spacious 330 m2 and used to be a restaurant however, it is closed today and need a renovation before it can reopen as a restaurant, supermarket or other business.

Ref.: 2294 Price: 530,000€

Charter Excursion Boat



Exclusively with FRINA is this Charter Boat, which is known for private and shared charters of high standards. The boat is a Sunseeker Apache 45 which brings up to 14 persons pr. trip that last from 3-5 hours.

Ref.: 2231 Price: 125,000€

+34 670 63 60 04

+34 922 08 51 91

frina@tenerife-business.com

tenerifebusinessforsale.com

we are here too

Calle Colón, 1st Floor, local 213, Puerto Colón, 38660 Adeje

English, Spanish, Flemish, Dutch, German, French, Danish

